

GENERAL PURPOSE ENGINE

GX120K1
[GC01-430/910]
[GC01B-100]

PARTS CATALOGUE

2



GX120K1

FOREWORD INDEX

1

ENGINE GROUP

2

PART NUMBER INDEX

3

PART NAME INDEX

4

Instruction for use of parts catalogue

- **This parts catalogue was prepared based on the latest information available as of October 01, 2007.**
- See the parts catalogue news for any revision that is made after October 01, 2007.
- **Always specify the part number when ordering a part.**
- Check the model, type, serial numbers, color, maker, and the size as needed before ordering a part.
- Note that the illustrations (part drawings) can differ from the actual parts in shape. They are given just to help you to refer to the parts.
- **When modifications or additions to this parts catalogue are made, a revised edition will be issued at an appropriate time, with successively progressing revision numbers on the cover. We recommend obtaining such revisions in order to keep your parts catalogue up-to-date at all times. To check whether a parts catalogue revision has been issued, please contact your Honda distributor.**

Initial version issue date **October 10, 2003**
Honda Motor Co., Ltd.

CONTENTS

	Page	Address No.	
● Instruction for use of parts catalogue	1	B 1	1
● How to refer to the part information	2	B 2	
● Part catalogue structure	3	B 3	
● When the parts were revised.....	4	B 4	
● Abbreviations used in the parts catalogue.....	4	B 4	
● How to check the part block and serial numbers.....	5	B 5	
● Models, parts catalogue codes and applicable serial numbers	6	B 6	
● Features of each type.....	10	B10	
● Fuel hose, general purpose hoses and vinyl hose	23	C 7	
● FLAT RATE SERVICE TIME	24	C 8	
● Illustrated index	29	C13	
● ENGINE GROUP.....	34	E 1	2
● PART NO. INDEX.....	148	M 1	3
● PART NAME INDEX.....	153	N 1	4



How to refer to the part information

A Reference with "Illustrated index"

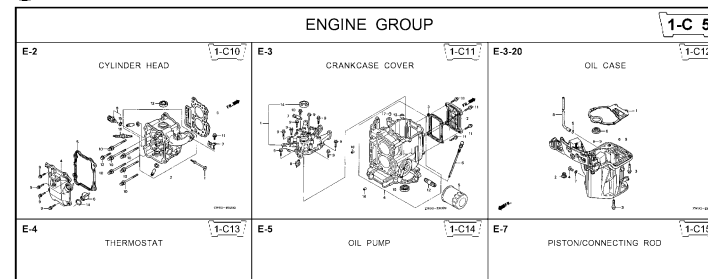

B Reference with "Part number index"

PART NO. INDEX

Part Number	Address	Page	Rel.	Part Number	Address	Page
06000				15212-ZW9-000	1-C14	3C
06316-ZW9-000	1-69	88	1	15220-ZW9-003	1-C14	3C
11000				15332-ZW9-000	1-E8	55
11300-ZW9-405	1-C11	27	1	15332-ZW9-A30	1-E11	5E
11300-ZW9-406	1-C11	27	1	15400-PFB-004	1-C11	27
11340-ZW9-000	1-C11	27	2	15422-ZW9-000	1-C14	3C
11342-ZW9-000	1-C11	27	3	15473-881-000	1-C14	3C
11381-ZW9-003	1-C12	28	1	15474-ZW9-000	1-C14	3C
				15611-921-000	1-C10	2E
				15655-ZW9-000	1-C11	27
12000				16000		
12000-ZW9-405ZA	1-C11	27	4	16010-ZV4-005	1-D4	3E
12155-ZV4-A00	1-C13	29	1	16011-ZV4-005	1-D4	3E
12166-ZW9-000	1-C10	26	1	16013-ZW9-003	1-D4	3E
12209-GB4-681	1-C16	32	1	16016-ZW9-003	1-D4	3E
12210-ZW9-405ZA	1-C10	26	2	16016-ZW9-721	1-D4	3E
12216-ZE2-300	1-E8	55	1	16023-ZW9-003	1-D4	3E
	1-E11	58	1	16024-ZV4-650	1-D4	3E
				16028-ZV4-650	1-D4	3E

C Reference with "Part name index"

PART NAME INDEX

Part name	Address	Page	Ref.
[A]			
ABSORBER , FUEL	1-E15	62	5
ARMATURE COMP.	1-D11	43	7
ARM COMP. , LINK JOINT	1-G6	85	18
ARM COMP. , SHIFT LINK	1-G6	85	14
ARM COMP. , TILT	1-F15	79	20
ARM , FUEL PUMP ROCKER	1-C16	32	4
ARM , REVERSE LOCK	1-F15	79	18
ARM , SHIFT LINK	1-F11	74	7
ARM , STOPPER	1-D1	33	12
ARM , THROTTLE REMOTE	1-F11	74	6
ARM , VALVE ROCKER	1-C16	32	3
[B]			
BAG , TOOL , 160MM	1-G5	84	10
BAND	1-G6	86	37
BAND B1 , WIRE	1-F6	69	1
BAND , CORD	1-F3	67	18
BAND , TUBE CLIP , 11MM	1-E15	63	20
BAND , TUBE CLIP , 12.5MM	1-E15	63	19

Address No. 1-C10

E-2 CYLINDER HEAD

Block No.

Ref No.

Ref. No.	Part No.	Description	Reqd. QTY						Serial No.	Parts catalogue code
			99D1	99D1	10D1	10D1	10B1	10B1		
1	12166-ZW9-000	STOPPER, ENGINE SIDE	2	2	2	2	2	2		
2	12210-ZW9-000ZA	HEAD COMP., CYLINDER	1	1	1	1	1	1		
3	12251-ZW9-003	GASKET, CYLINDER HEAD	1	1	1	1	1	1		
4	12310-ZW9-000	COVER COMP., HEAD	1	1	1	1	1	1		
5	12312-ZW9-000	PACKING, HEAD COVER	1	1	1	1	1	1		
6	15611-921-000	CAP, OIL (NO GAUGE)	1	1	1	1	1	1		
7	16617-ZW9-000	HOLDER, CABLE	1	1	1	1	1	1	SC,SG	
	16617-ZW9-010		1	1	1	1	1	1	1001800 LHC,LHD	
			1	1	1	1	1	1	1001801 LHC,LHD	
8	35673-ZW5-003	SENSOR ASSY., WATER	1	1	1	1	1	1		
9	90003-ZW9-000	BOLT, FLANGE, 6X22	4	4	4	4	4	4		
10	90007-ZW9-003	BOLT, FLANGE, 8X83	6	6	6	6	6	6		
11	90011-ZW9-000	BOLT, FLANGE, 6X14 (CT200)	1	1	1	1	1	1		
12	90020-ZW9-000	BOLT, FLANGE, 8X40	2	2	2	2	2	2		
13	91202-KJ9-003	OIL SEAL, 20X32X6	1	1	1	1	1	1		
14	91301-805-000	O-RING, 26X2.7	1	1	1	1	1	1		
15	91307-PK2-005	O-RING, 9.5X1.5 (HONDA KIKAKI)	1	1	1	1	1	1		
16	98059-55916	PLUG, SPARK (CR5EH-9)	2	2	2	2	2	2		
	98059-55926	PLUG, SPARK (U16FER9)	2	2	2	2	2	2		

ZW83-80200

2000.09.20 E

Page No.

Part catalogue structure

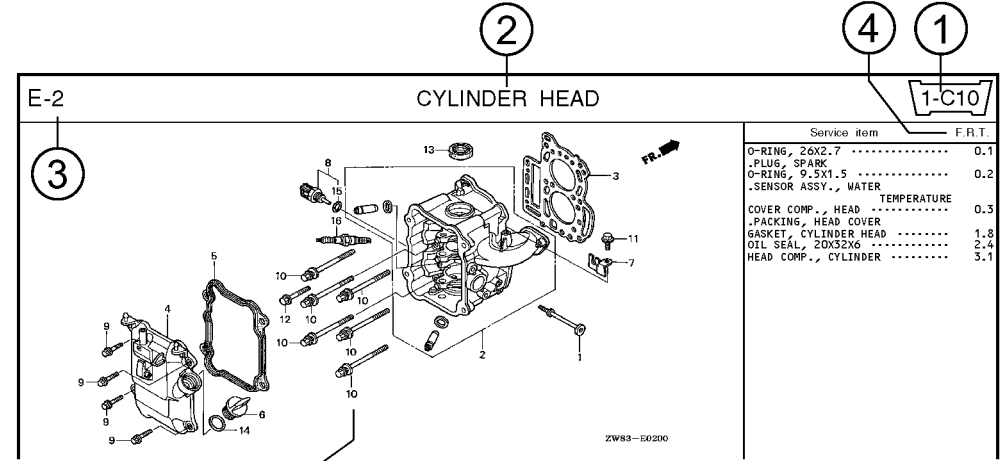

Ref. No.	Part No.	Description	Reqd. QTY						Serial No.	Parts catalogue code
			BF 9.9D1	BFP 9.9D1	BF 10D1	BFP 10D1	BF 10B1	BFP 10B1		
1	12166-ZW9-000	STOPPER, ENGINE SIDE	2	2	2	2	2	2		
2	12210-ZW9-000ZA	HEAD COMP., CYLINDER *NH8*	1	1	1	1	1	1		
3	12251-ZW9-003	GASKET, CYLINDER HEAD	1	1	1	1	1	1		
4	12310-ZW9-000	COVER COMP., HEAD	1	1	1	1	1	1		
5	12312-ZW9-000	PACKING, HEAD COVER	1	1	1	1	1	1		
6	15611-921-000	CAP., OIL (NO GAUGE)	1	1	1	1	1	1		
7	16617-ZW9-000 16617-ZW9-010	HOLDER, CABLE	1	1	1	1	1	1	----- SC,S6 1001800 LHC,LHD	

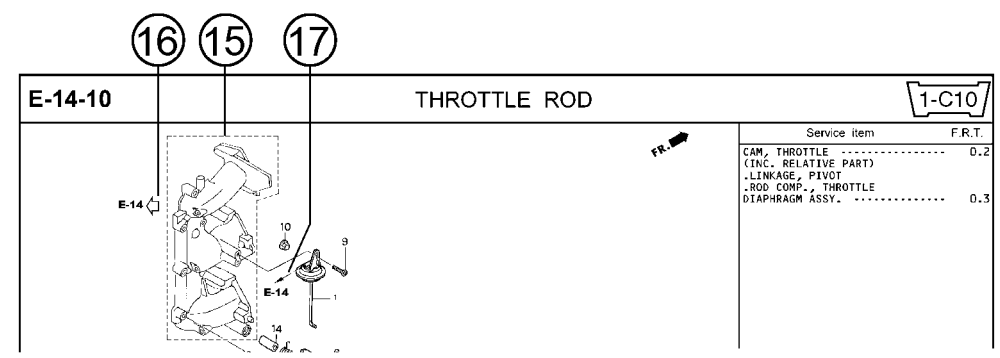

- ① **Address number**
 - Address No. is provided (in place of the page No.) to help you refer to the part with the part No. or part name.
- ② **Block title** ③ **Block number**
- ④ **Service item/Flat rate time**
- ⑤ **Reference number**
 - Title number marked with the parenthesis or parentheses indicates that it continues from the previous page.
- ⑥ **Part number** ⑦ **Honda color code**
- ⑧ **Description**
- ⑨ **Assemblies**
 - Sections framed with broken lines in the exploded view drawings are available as complete assemblies. (Their individual parts can also be obtained.)
- ⑩ **Color description**
- ⑪ **Note**
 - Notes are shown with the parentheses in the part name column.
- ⑫ **Required quantity**
 - Required QTY shown in the parenthesis or parentheses indicates the optional part.
 - Required QTY marked with "N" Indicates the optional part that should be selected as needed.
 - Required QTY indicates the number of the part used in the block.
- ⑬ **Serial number**
- ⑭ **Type**
 - When the type column is blank, it indicates that the part is applicable to all types.
 - As the type of the actual unit may differ from the "parts catalogue, type" please refer to "Models, types and applicable serial numbers" for confirmation.
- ⑮ **[Dotted box]**
 - Parts enclosed within a dotted line [] are covered in a different block.
- ⑯ **[Hollow arrow]**
 - A hollow arrow ↖ indicates the block No. for the parts enclosed within a dotted line [] .
- ⑰ **[Solid arrow]**
 - A solid arrow ← indicates the block No. the part in question is connected to.

When the parts were revised

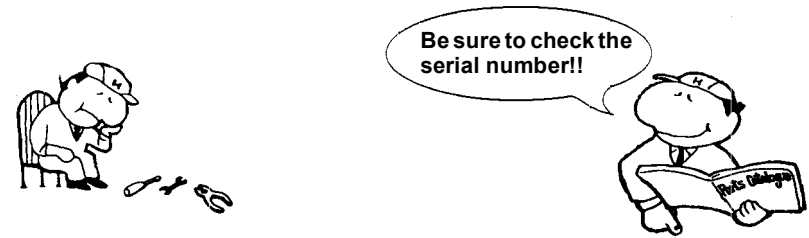

Ref. No.	Part No.	Description	Reqd. QTY						Serial No.
			BF 99D1	BFP 9.9D1	BF 10D1	BFP 10D1	BF 10B1	BFP 10B1	
1	12166-ZW9-000	STOPPER, ENGINE SIDE	2	2	2	2	2	2	
2	12210-ZW9-000ZA	HEAD COMP., CYLINDER *NH8*.....DARK GRAY	1	1	1	1	1	1	
3	12251-ZW9-003	GASKET, CYLINDER HEAD	1	1	1	1	1	1	
4	12310-ZW9-000	COVER COMP., HEAD	1	1	1	1	1	1	
5	12312-ZW9-000	PACKING, HEAD COVER	1	1	1	1	1	1	
6	15611-921-000	CAP, OIL (NO GAUGE)	1	1	1	1	1	1	
7	16617-ZW9-000	HOLDER, CABLE (###).....	1	1	1	1	1	1	
	16617-ZW9-010	1	1	1	1	1	1	

The number has been used from the initial model without revision. When shown at the left side, it is applicable to the models of No.1001801 and the subsequent numbers. When shown at the right side, it is applicable to the models up to No.1001800.

• The parts listed with "###" at the end of the parts name have limited supply period (parts not for sale).

Abbreviations used in the parts catalogue

• The following abbreviations are used in the parts name column.

- A Ampere
- A.C. Alternating current
- ASSY. Assembly
- AT. Automatic transmission
- C.D.I. Capacitive discharge ignition
- COMP. ... Complete
- D.C. Direct current
- EX. Exhaust
- G.F.C.I ... Ground fault circuit interruptor
- HEX. Hexagonal
- H.S.T. Hydrostatic transmission
- FR.Front
- IN.Inlet
- L (100L) .Link (100 Links)
- L.Left
- MMMillimeter
- MT.Manual Transmission
- P.T.O.Power take off
- R.Right
- RR.Rear
- STD.Standard
- T (22T) ...Tooth (22 Teeth)
- VVolt
- WWatt

How to check the part block and serial numbers

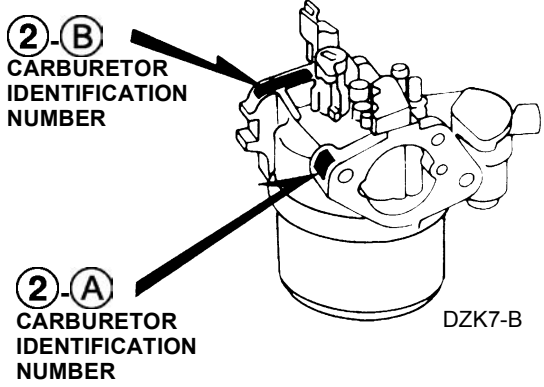
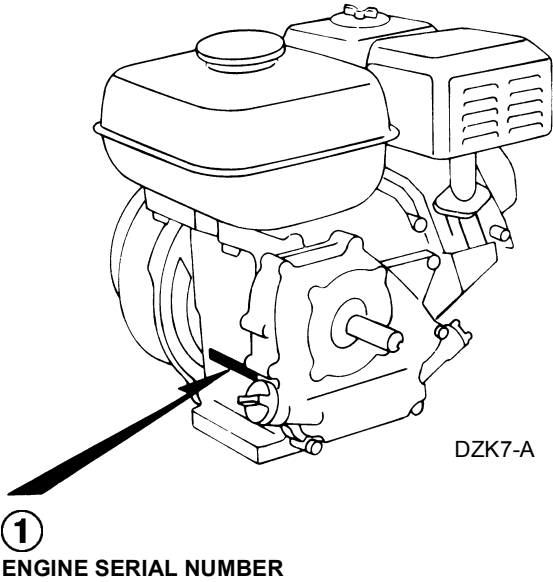
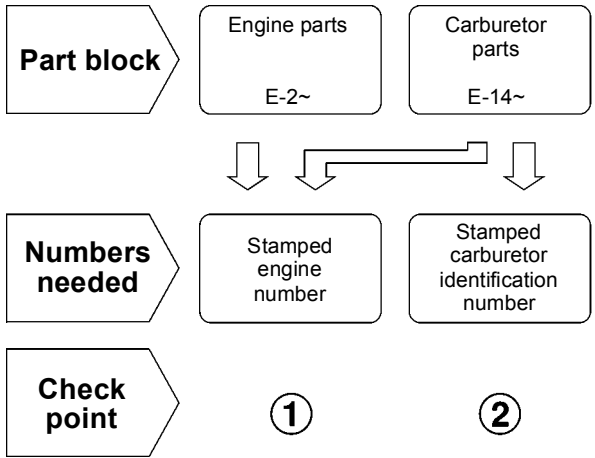

Models, parts catalogue codes and applicable serial numbers

- Models, parts catalogue codes and applicable serial Nos. given in this parts catalogue can be identified as follows.

Model	Type	Parts catalogue type	Applicable engine serial No.	Applicable carburetor identification No.	Model	Type	Parts catalogue type	Applicable engine serial No.	Applicable carburetor identification No.
GX120K1 (1)	AR	AR	GC01-4300001~ 9099999	BE62C A	GX120K1 (1)	KRT4	KRT4	GC01-4300001~ 9099999	BE62C A
	ARL	ARL	GC01-4300001~			KRT6	KRT6	GC01-4300001~	BE62A A
	DKR	DKR	GC01-4300001~ 9099999			LAJ	LAJ		BE60C B
	DS	DS	GC01-4300001~	BE60C B		LAJ4	LAJ4	GC01-4300001~ 9099999	BE60B B
	HHQ4	HHQ4	GC01-4300001~ 9099999	BE60B B		LD	LD		BE61D B
	HTF2	HTF2				LH	LH	GC01-4300001~	BE60B B
	HT2	HT2				LHQ4	LHQ4		
	HT24	HT24				LJ	LJ	GC01-4300001~	BE60C B
	HX	HX	GC01-4300001~	LJC		LJC	BE60L A		
	HXU	HXU	GC01-4300001~ 9099999	LJC8		LJC8			
	HX2	HX2		LJD2		LJD2	GC01-4300001~ 9099999	BE60B B	
	HX26	HX26		LJS		LJS	GC01-4300001~	BE60C B	
	HX4	HX4		LSJ		LSJ	GC01-4300001~ 9099999		
	KR	KR	GC01-4300001~	BE62C A		LSJ4		LSJ4	BE61D B
	KRA4	KRA4	GC01-4300001~ 9099999	BE62A A, BE62C A		LTJ	LTJ	GC01-4300001~	BE60B B
	KRF4	KRF4		BE62C A		LTK1	LTK1		BE60L A
	KRS4	KRS4				LTR	LTR		BE60C B
	KRS5	KRS5				LTS	LTS	BE60B B	
	KRS6	KRS6		LX		LX			
	KRT	KRT		GC01-4300001~		LXU	LXU		GC01-4300001~ 9099999

Model	Type	Parts catalogue type	Applicable engine serial No.	Applicable carburetor identification No.
GX120K1 (1)	LX2	LX2	GC01-4300001~ 9099999	BE60B B
	LX4	LX4		
	PX	PX	GC01-4300001~	
	PX2	PX2	GC01-4300001~ 9099999	BE12C B
	QA	QA		BE60C B
	QA2	QA2		
	QB26	QB26	GC01-4300001~	BE60M A
	QD	QD	GC01-4300001~ 9099999	BE61D B
	QH	QH	GC01-4300001~	BE60B B
	QH4	QH4	GC01-4300001~ 9099999	
	QH26	QH26		
	QJG2	QJG2		
	QLL	QLL		BE12A C, BE60B B
	QM	QM	GC01-4300001~	BE12B C
	QMA4	QMA4	GC01-4300001~ 9099999	BE60B B
	QMA8	QMA8		BE60L A, BE60C B
	QME4	QME4		BE60B B
	QMX2	QMX2		BE60L A
	QT	QT		BE60B B
	QWA4	QWA4		

Model	Type	Parts catalogue type	Applicable engine serial No.	Applicable carburetor identification No.	
GX120K1 (1)	QX	QX	GC01-4300001~	BE60B B	
	QXC9	QXC9	GC01-4300001~ 9099999	BE60F B	
	QXS2	QXS2		BE60B B	
	QXU	QXU			
	QX2	QX2			
	QX26	QX26			
	QX4	QX4			
	QX7	QX7			
	RD	RD			BE61D B
	RD4	RD4			BE12A C, BE60B B
	RHC	RHC			
	RHQ4	RHQ4	BE60B B		
	RX	RX		GC01-4300001~	
	RX4	RX4	GC01-4300001~ 9099999	BE60C B	
	SAJ	SAJ	GC01-4300001~	BE60B B	
	SAJ4	SAJ4	GC01-4300001~ 9099999	BE60C B	
	SAR4	SAR4		BE61D B	
	SCJ	SCJ	GC01-4300001~	BE60C B	
	SD	SD	GC01-4300001~ 9099999	BE61D B	
	SD16	SD16			

Model	Type	Parts catalogue type	Applicable engine serial No.	Applicable carburetor identification No.
GX120K1 (1)	SD4	SD4	GC01-4300001~ 9099999	BE61D B
	SE	SE		BE61G A
	SG24	SG24		BE60B B
	SH	SH		
	SHQ4	SHQ4		
	SJ	SJ		
	SJC1	SJC1	GC01-4300001~	BE60C B
	SJC5	SJC5		
	SJD2	SJD2	GC01-4300001~ 9099999	BE60B B
	SKR	SKR	GC01-4300001~	BE60C B
	SMA7	SMA7	GC01-4300001~ 9099999	BE60B B
	SMJ	SMJ	GC01-4300001~	
	SMW2	SMW2	GC01-4300001~ 9099999	
	SM11	SM11	GC01-4300001~	
	SM12	SM12	GC01-4300001~ 9099999	
	SM14	SM14		
	SSK1	SSK1		
	SSK3	SSK3	GC01-4300001~	
	SSX2	SSX2	GC01-4300001~ 9099999	
	SSX4	SSX4		

Model	Type	Parts catalogue type	Applicable engine serial No.	Applicable carburetor identification No.
GX120K1 (1)	STP	STP	GC01-4300001~	BE12A C
	STS	STS		BE13A B
	SWX2	SWX2	GC01-4300001~ 9099999	BE60B B
	SWX4	SWX4		
	SX	SX	GC01-4300001~	
	SXS4	SXS4	GC01-4300001~ 9099999	
	SX4	SX4		
	SX7	SX7		
	SYA	SYA	GC01-4300001~	BE60S A/B
	TX	TX	GC01-4300001~ 9099999	BE60B B
	TX2	TX2		
	TX26	TX26		
	TX4	TX4		
	UXU	UXU		
	VED	VED	GC01-4300001~	BE60C B
	VED1	VED1	GC01-4300001~ 9099999	
	VED6	VED6		
	VEE1	VEE1		BE60B B
	VEK	VEK	GC01-4300001~	BE12H B
	VET	VET	GC01-4300001~ 9099999	BE60C B

Model	Type	Parts catalogue type	Applicable engine serial No.	Applicable carburetor identification No.
GX120K1 (1)	VEX	VEX	GC01-4300001~ 9099999	BE60B B
	VEX7	VEX7		
	VMS4	VMS4		
	VMT	VMT	GC01-4300001~	BE28B A
	VPM4	VPM4	GC01-4300001~ 9099999	BE62E A
	VPR4	VPR4		BE28B A
	VSX	VSX	GC01-4300001~	BE12A C
	VSX1	VSX1		
	VX	VX	GC01-4300001~ 9099999	BE60B B
	VXU	VXU		
	VX4	VX4		
	VX7	VX7		
	WDA6	WDA6		
	WD12	WD12		
	WJ	WJ	GC01-4300001~	BE60C B
	WJP	WJP	GC01-4300001~ 9099999	
	WKD6	WKD6		
	WKT2	WKT2		
WKT4	WKT4			
WKT6	WKT6			

Model	Type	Parts catalogue type	Applicable engine serial No.	Applicable carburetor identification No.
GX120K1 (1)	WMA3	WMA3	GC01-4300001~ 9099999	BE61D B
	WMA4	WMA4	GC01-4300001~	
	WME2	WME2	GC01-4300001~ 9099999	BE60C B
	WME4	WME4		
	WMK	WMK	GC01-4300001~	BE61D B
	WM1	WM1	GC01-4300001~ 9099999	
GX120K1 (2)	H1	H1	GC01-4300001~	BE12B C, BE13A B BE12A C, BE12C B
	L1	L1		
	Q1	Q1		
	R1	R1		
	S1	S1		
	W1	W1		
GX120K1 (3) (Indonesia-KD)	SIH	SIH	GC01-9100001~	BE12A A/B/C BE60L A
	WIH	WIH		
	WIS	WIS		BE60L A
GX120K1 (4) (Brazil-KD)	QDBR	QDBR	GC01B-1000001~ 9999999	BE61D B
	QXBR	QXBR		BE60B B
	TXBR	TXBR		
	VXBR	VXBR		

* Of carburetor identification numbers, only the portions underlined in the example below are used for registration.

BE 62C A KC ナ
 (A) (B)

Features of each type

• See the following table for the features of each type. (Items in brackets are optional)

1

Specifications		Model	GX120K1												
		Type	Standard equipment (1)												
		AR	ARL	DKR	DS	HHQ4	HTF2	HT2	HT24	HX	HXU	HX2	HX26	HX4	
Crankshaft	18mm Ø Straight														
	19.05mm Ø Straight														
	20mm Ø Spline	●	●	●	●										
	21mm Ø Spline					●	●	●	●	●	●	●	●	●	
	19.8mm Ø Tapered														
	22mm Ø Tapered														
	3/4" Thread														
	5/8" Thread														
	M14 Stepped thread														
	M16 Stepped thread														
1/2" Stepped thread															
Reduction		●	●	●	●	●	●	●	●	●	●	●	●	●	
Fuel tank					●	●	●	●	●	●	●	●	●	●	
Oil alert							●			●	●	●	●	●	
Lamp coil															

Specifications		Model	GX120K1											
		Type	Standard equipment (1)											
		KR	KRA4	KRF4	KRS4	KRS5	KRS6	KRT	KRT4	KRT6	LAJ	LAJ4	LD	LH
Crankshaft	18mm Ø Straight													
	19.05mm Ø Straight													
	20mm Ø Spline	●	●	●	●	●	●	●	●	●	●	●	●	●
	21mm Ø Spline													
	19.8mm Ø Tapered													
	22mm Ø Tapered													
	3/4" Thread													
	5/8" Thread													
	M14 Stepped thread													
	M16 Stepped thread													
	1/2" Stepped thread													
Reduction		●	●	●	●	●	●	●	●	●	●	●	●	●
Fuel tank											●	●	●	●
Oil alert														
Lamp coil											●	●		

Specifications		Model	GX120K1											
		Type	Standard equipment (1)											
			LHQ4	LJ	LJC	LJC8	LJD2	LJS	LSJ	LSJ4	LTJ	LTK1	LTR	LTS
Crankshaft	18mm Ø Straight													
	19.05mm Ø Straight													
	20mm Ø Spline	●	●	●	●	●	●	●	●	●	●	●	●	●
	21mm Ø Spline													
	19.8mm Ø Tapered													
	22mm Ø Tapered													
	3/4" Thread													
	5/8" Thread													
	M14 Stepped thread													
	M16 Stepped thread													
1/2" Stepped thread														
Reduction		●	●	●	●	●	●	●	●	●	●	●	●	●
Fuel tank		●	●	●	●	●	●	●	●	●	●	●	●	●
Oil alert				●	●									●
Lamp coil							●							

Specifications		Model	GX120K1											
		Type	Standard equipment (1)											
			LXU	LX2	LX4	PX	PX2	QA	QA2	QB26	QD	QH	QH26	QJG2
Crankshaft	18mm Ø Straight													
	19.05mm Ø Straight						●	●	●	●	●	●	●	
	20mm Ø Spline	●	●	●										
	21mm Ø Spline													
	19.8mm Ø Tapered													
	22mm Ø Tapered													
	3/4" Thread				●	●								
	5/8" Thread													
	M14 Stepped thread													
	M16 Stepped thread													
1/2" Stepped thread														
Reduction		●	●	●										
Fuel tank		●	●	●	●	●	●		●	●	●	●	●	
Oil alert		●	●	●	●	●								
Lamp coil								●					●	

Specifications		Model	GX120K1											
		Type	Standard equipment (1)											
		QLL	QM	QMA4	QMA8	QME4	QMX2	QT	QWA4	QX	QXC9	QXS2	QXU	QX2
Crankshaft	18mm Ø Straight													
	19.05mm Ø Straight	●	●	●	●	●	●	●	●	●	●	●	●	●
	20mm Ø Spline													
	21mm Ø Spline													
	19.8mm Ø Tapered													
	22mm Ø Tapered													
	3/4" Thread													
	5/8" Thread													
	M14 Stepped thread													
	M16 Stepped thread													
1/2" Stepped thread														
Reduction														
Fuel tank		●	●	●	●	●	●	●	●	●	●	●	●	●
Oil alert		●			●		●		●	●	●	●	●	●
Lamp coil											●			

Specifications		Model	GX120K1											
		Type	Standard equipment (1)											
			QX26	QX4	QX7	RD	RD4	RHC	RHQ4	RX	RX4	SAJ	SAJ4	SAR4
Crankshaft	18mm Ø Straight				●	●	●	●	●	●	●	●	●	●
	19.05mm Ø Straight	●	●	●										
	20mm Ø Spline													
	21mm Ø Spline													
	19.8mm Ø Tapered													
	22mm Ø Tapered													
	3/4" Thread													
	5/8" Thread													
	M14 Stepped thread													
	M16 Stepped thread													
1/2" Stepped thread														
Reduction					●	●	●	●	●	●				
Fuel tank		●	●	●	●	●		●	●	●	●	●	●	●
Oil alert		●	●	●				●	●					
Lamp coil							●							

Specifications		Model	GX120K1											
		Type	Standard equipment (1)											
			SD	SD16	SD4	SE	SG24	SH	SHQ4	SJ	SJC1	SJC5	SJD2	SKR
Crankshaft	18mm Ø Straight	●	●	●	●	●	●	●	●	●	●	●	●	●
	19.05mm Ø Straight													
	20mm Ø Spline													
	21mm Ø Spline													
	19.8mm Ø Tapered													
	22mm Ø Tapered													
	3/4" Thread													
	5/8" Thread													
	M14 Stepped thread													
	M16 Stepped thread													
	1/2" Stepped thread													
Reduction														
Fuel tank		●	●	●	●	●	●	●	●	●	●	●	●	●
Oil alert						●			●	●			●	
Lamp coil														

Specifications		Model	GX120K1											
		Type	Standard equipment (1)											
		SMJ	SMW2	SM11	SM12	SM14	SSK1	SSK3	SSX2	SSX4	STP	STS	SWX2	SWX4
Crankshaft	18mm Ø Straight	●	●	●	●	●	●	●	●	●	●	●	●	●
	19.05mm Ø Straight													
	20mm Ø Spline													
	21mm Ø Spline													
	19.8mm Ø Tapered													
	22mm Ø Tapered													
	3/4" Thread													
	5/8" Thread													
	M14 Stepped thread													
	M16 Stepped thread													
	1/2" Stepped thread													
Reduction														
Fuel tank		●	●	●	●	●	●	●	●	●	●	●	●	●
Oil alert		●	●		●	●			●	●			●	●
Lamp coil														

Specifications		Model	GX120K1											
		Type	Standard equipment (1)											
		SX	SXS4	SX4	SX7	SYA	TX	TX2	TX26	TX4	UXU	VED	VED1	VED6
Crankshaft	18mm Ø Straight	●	●	●	●	●								
	19.05mm Ø Straight													
	20mm Ø Spline													
	21mm Ø Spline													
	19.8mm Ø Tapered													
	22mm Ø Tapered											●	●	●
	3/4" Thread													
	5/8" Thread						●	●	●	●				
	M14 Stepped thread													
	M16 Stepped thread													
	1/2" Stepped thread										●			
Reduction														
Fuel tank		●	●	●	●		●	●	●	●	●	●	●	●
Oil alert		●	●	●	●		●	●	●	●	●		●	●
Lamp coil						●								

Specifications		Model	GX120K1											
		Type	Standard equipment (1)											
		VEE1	VEK	VET	VEX	VEX7	VMS4	VMT	VPM4	VPR4	VSX	VSX1	VX	VXU
Crankshaft	18mm Ø Straight													
	19.05mm Ø Straight													
	20mm Ø Spline													
	21mm Ø Spline													
	19.8mm Ø Tapered				●	●	●		●	●	●	●	●	●
	22mm Ø Tapered	●	●	●				●						
	3/4" Thread													
	5/8" Thread													
	M14 Stepped thread													
	M16 Stepped thread													
	1/2" Stepped thread													
Reduction														
Fuel tank		●	●	●	●	●	●				●	●	●	●
Oil alert		●			●	●	●	●	●	●	●	●	●	●
Lamp coil														

		Model	GX120K1												
		Type	Standard equipment (1)												
Specifications			VX4	VX7	WDA6	WD12	WJ	WJP	WKD6	WKT2	WKT4	WKT6	WMA3	WMA4	WME2
Crankshaft	18mm Ø Straight														
	19.05mm Ø Straight														
	20mm Ø Spline														
	21mm Ø Spline														
	19.8mm Ø Tapered	●	●												
	22mm Ø Tapered														
	3/4" Thread														
	5/8" Thread														
	M14 Stepped thread			●	●	●		●	●	●	●	●	●	●	
	M16 Stepped thread							●							●
	1/2" Stepped thread														
Reduction															
Fuel tank		●	●	●	●	●	●	●	●	●	●	●	●	●	●
Oil alert		●	●					●	●	●	●				●
Lamp coil															

Specifications		Model	GX120K1										
		Type	Standard equipment (1)			Selective equipment (2)					Indonesia-KD (3)		
			WME4	WMK	WM1	H1	L1	Q1	R1	S1	W1	SIH	WIH
Crankshaft	18mm Ø Straight							●	●		●		
	19.05mm Ø Straight							●					
	20mm Ø Spline					●							
	21mm Ø Spline				●								
	19.8mm Ø Tapered												
	22mm Ø Tapered												
	3/4" Thread												
	5/8" Thread												
	M14 Stepped thread		●	●						●		●	
	M16 Stepped thread	●											●
1/2" Stepped thread													
Reduction					●	●		●					
Fuel tank		●	●	●	(●)	(●)	(●)	(●)	(●)	(●)	●	●	●
Oil alert					(●)	(●)	(●)	(●)	(●)	(●)			
Lamp coil					(●)	(●)	(●)	(●)	(●)	(●)			

Specifications		Model	GX120K1			
		Type	Brazil-KD (4)			
			QDBR	QXBR	TXBR	VXBR
Crankshaft	18mm Ø Straight					
	19.05mm Ø Straight	●	●			
	20mm Ø Spline					
	21mm Ø Spline					
	19.8mm Ø Tapered				●	
	22mm Ø Tapered					
	3/4" Thread					
	5/8" Thread			●		
	M14 Stepped thread					
	M16 Stepped thread					
	1/2" Stepped thread					
Reduction						
Fuel tank		●	●	●	●	
Oil alert			●	●	●	
Lamp coil						

Fuel hose, general purpose hoses and vinyl hose

- The standard part fuel hose, general purpose hose and vinyl hose may be substituted by the coiled bulk part.
- When ordering the standard part fuel hose, general purpose hose and vinyl hose use the bulk part number written in the parts catalog in brackets () underneath the part name.
- When exchanging the hose, cut and use at the specified length as mentioned in the part name.
(For the method of cutting the bulk part, and method of filling out orders etc., please refer to the instructions issued with the bulk part.)

Bulk part number of fuel hose, general purpose hose and vinyl hose.

Example: 9 5 0 0 1 - 7 5 0 0 1 - 5 0 M

Bulk part number:
Refers to the bulk part.

Marking code (fuel hose and general purpose hose)

Change code (Vinyl hose)

Indicates number mark or change sequence, however, the code for the bulk part must be strictly 0 (zero).

Types of code:

- | | | | | | |
|-------------|--|----------------|--|--------------|---|
| • Fuel hose | 2: Red outside braid
(3 mm inside dia. only) | • General hose | 1: Ash gray
2: Ash gray
3: Black
5: Black | • Vinyl hose | 1: Clear
2: Black
3: Light red
6: Light red
7: Pale black |
| | 5: Black inside braid | | | | |
| | 3: Red (3 mm inside dia. only) | | | | |
| | 4: Ash gray with red stripe
(3 mm inside dia. only) | | | | |
| | 6: Black | | | | |

Lengths:

- 001: 1 m (standard)
003: 3 m
008: 8 m } Application or specification of some parts is not settled.

I.D code: (fuel hose and general purpose hose)

- | | | | | |
|------------|--------------------|--------------------|-----------------------------|-----------------------------|
| 30: 3.0 mm | 50: 5.0 mm | 70: 7.0 mm | 11: 11 mm | 12: 12 (outside dia. 17) mm |
| 35: 3.5 mm | 55: 5.3 mm, 5.5 mm | 75: 7.3 mm, 7.5 mm | 91: 12 (outside dia. 15) mm | 14: 14 mm |
| 45: 4.5 mm | 65: 6.5 mm | 80: 8.0 mm | 92: 12 (outside dia. 16) mm | 17: 17 mm |

ID./OD. code: (vinyl hose)

- | | | | | |
|-------------------------|--------------------------|---------------------------|---------------------------|---------------------------|
| 01: ID. 2.9, OD. 6.8 mm | 12: ID. 5.0, OD. 7.0 mm | 21: ID. 8.0, OD. 9.0 mm | 37: ID. 11.0, OD. 15.0 mm | 50: ID. 16.0, OD. 19.0 mm |
| 03: ID. 3.0, OD. 6.0 mm | 10: ID. 5.0, OD. 8.0 mm | 23: ID. 8.0, OD. 12.0 mm | 38: ID. 12.0, OD. 13.0 mm | 55: ID. 17.5, OD. 20.5 mm |
| 05: ID. 3.5, OD. 6.5 mm | 11: ID. 5.0, OD. 9.0 mm | 25: ID. 9.0, OD. 11.0 mm | 39: ID. 12.0, OD. 14.0 mm | 60: ID. 22.0, OD. 27.0 mm |
| 07: ID. 4.0, OD. 7.0 mm | 14: ID. 6.0, OD. 9.0 mm | 27: ID. 9.0, OD. 13.0 mm | 40: ID. 12.0, OD. 16.0 mm | |
| 08: ID. 4.5, OD. 6.5 mm | 17: ID. 7.0, OD. 9.0 mm | 33: ID. 10.0, OD. 14.0 mm | 43: ID. 13.0, OD. 15.0 mm | |
| 09: ID. 4.5, OD. 8.0 mm | 19: ID. 7.0, OD. 11.0 mm | 36: ID. 11.0, OD. 13.0 mm | 45: ID. 14.0, OD. 18.0 mm | |

Hose type:

- 1: Fuel hose
3: Vinyl hose
5: General hose

© **CAUTION: It is DANGEROUS to confuse the fuel hose with the general purpose hose or vinyl hose.**

Never use a general purpose hose or vinyl hose in place of a fuel hose or vice versa. Always use the correct bulk part in the parts catalogue, according to the service manual or the instructions issued with the bulk part.

FLAT RATE SERVICE TIME

Flat rate service time (FRT) means the standard time required to service a product, which is listed in this manual to help the dealers control the actual working process and calculate the service charge by using it as a guide.

FRT setting system

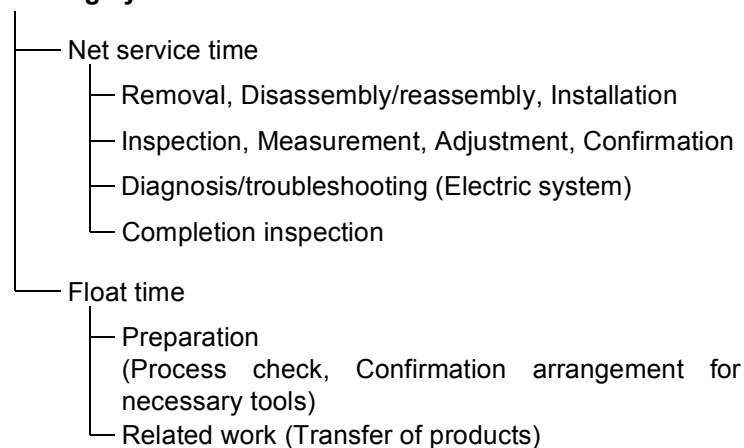

* Float time is set by multiplying the net service time by a given coefficient.

Editorial style

The service items shown in the text are listed with the exchange work time for the repair sales parts as the subject. Other representative service items not using repair parts (removal/installation, adjustment, inspection/measuring, and other work) are listed collectively in the list in the preface, classified according to the work.

FRT setting standard

- Decimal system (in unit of 0.1) is adopted to set FRT as it is convenient to calculate the wage.
Example: (0.1) → 6 minutes, (0.2) → 12 minutes
[Labor cost per hour] x [FRT] = [Wage]
- FRT is set with a hand tool.
- Service items and FRT can be subject to change depending on development of tools and service equipment and improvement in service procedure.

Work procedure

- As the work procedure is set with the work time according to the method in the separate Service Manual, refer to this Manual as required.
- Work methods permitting servicing in the shortest time still permitting assurance of safe work and product warranty are used for the setting of service items not listed in the Service Manual.
- Work basically is to be performed by one person, and when two or more people are required, setting is done as the total time for the number of people.
- The set value for the technological level of the workers uses a person with three years of experience in the repair of Honda products as the standard.
- Special tools and service equipment used to set FRT are those specified or recommended in Service Manual.

Service item whose FRT is not presented

- Accessories and service parts that are not listed to use in this manual.
 - Locations with little aging deterioration or breakage during normal use.
 - Service work that can be finished by one touch.
 - Service work that is seldom done (i.e. extremely small causes of trouble and service frequency).
 - Products and parts whose location for installation differs according to its status of use and application.
- * When FRT is not presented, please calculate wages based on appropriate actual work time.

Operation not included of FRT

- Oil and coolant water draining, Waiting time for warming up operation and etc..
- Additional operation that involves removal/installation of standard exterior equipment.
- Indirect time spent for service by visiting the customer, trade-in, and delivery.
- Indirect time required for ordering and delivery of parts.
- Cost for grease, adhesive agent, etc. used for service work.

Explanation of FRT by using an example
(The example may differ from the actual presented items)

Ref. No.	L.O.N.	Description	(Relative ref. Number)	F.R.T.
①	1111L1	VALVE, INTAKE4.1	④	②
②		• NOTE: OHV type	⑥	⑦
③	1111L1A	One head (intake all) add1.4		⑤

- ① Reference No. of the illustration of part that shows location of the replacement work.
- ② FRT is an abbreviation of Flat Rate Time indicating the standard service time required for the replacement.
- ③ LON is an abbreviation of Labor Operation Number, and it is a classification of the service items by the work unit code.

The same operation code is used regardless of the models.

Standard operation is indicated with 6 digits code, and additional operation is indicated with 7 digits code.

- ④ Indicating the intake valve replacement and FRT4.1.
- ⑤ Indicating FRT1.4 that will be added when additional operation (whole intake side of one cylinder head) is done in association with intake valve replacement.

- ⑥ Indicating work condition or application condition of the service item.
- ⑦ Indicating work contents that are included in the service item.
- ⑧ Indicating a reference No. whose operation and time are the same as FRT4.1 for the intake valve.

(The application range is limited to the service items without an LON setting within a same block.)

How to refer to the service item by using the sample
(intake valve replacement)

Open to the page of the block where the intake valve's spare part illustration is shown.

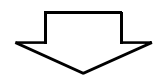

Look for the intake valve illustration, and refer to the service item and FRT that agree with the reference No.

Indication mark for the listing of service items that continues to the following page

Ref. No.	L.O.N.	(Relative ref. Number) Description	F.R.T.
2	1111L1	VALVE, INTAKE	4.1
	.	.	.
	.	.	.

+

Mark indicated at the last line.

Indication of the block with no setting of FRT

Ref. No.	L.O.N.	(Relative ref. Number) Description	F.R.T.
NO INFORMATION			

• LON code system

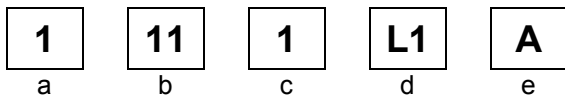

- a) Category code..... Engine
- b) Location/function code Engine upper
- c) Operation code..... Replace
- d) Operation sequence number (Unit code can be shown with alphabet)
..... Intake valve
(No regular rule of code)
- e) Additional code One head (intake all)
(No regular rule of code)

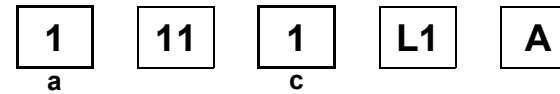

a) Category codes and classification

Code	Category
1	Engine
2	Power drive
3	Fuel & Exhaust
4	Frame & Body
5	Steering
6	Electrical
7	Axle & Brake
8	Control system
9	-
0	Attachments

c) Operation codes and classification

Code	Operation category
1	Replace, Removal/Installation, Change
2	Overhaul
3	Adjust, Rotation
4	(Paint-related work: Top-coat)
5	Test, Inspect/diagnose, Measurement
6	(Overhaul-related work: Rebore)
7	(Overhaul-related work: Reseal)
8	(Resurface)
9	(Paint-related work: Refinish)
0	Repair, Cleaning, Air bleeding

Major service items without using spare parts

(1) Removal/Installation, (2) Adjustment,
(3) Inspection/Masurement, (4) Overhaul, (5) Other work

E: Engine, T: Transmission, D: Drive system,
B: Body and related parts

(1) Removal/Installation

Set with the parts configuration in the status of being removed from the product.

	LON	DESCRIPTION	FRT
E	1111L3	CYLINDER HEAD ASSEMBLY-REMOVAL/INSTALLATION	0.5

(2) Adjustment

	LON	DESCRIPTION	FRT
E	1113A1	VALVE CLEARANCE-ADJUSTMENT NOTE: For 1 product	0.3
	1163A0	CONTROL, THROTTLE/GOVERNOR-ADJUSTMENT	0.2
	3113A2	CARBURETOR IDLE-ADJUSTMENT	0.2

(3) Inspection, Measurement, Cleaning

	LON	DESCRIPTION	FRT
E	1105A0	ENGINE OIL-INSPECTION	0.1
	3120A0	AIR CLEANER-CLEANING INCLUDES: Air cleaner-inspection	0.2
	3130A0	SPARK ARRESTER-CLEANING	0.2
	6140A0	SPARK PLUG-ADJUSTMENT/CLEANING NOTE: For 1 product	0.1

(4) Overhaul

Work condition: The required Measurements, inspections, adjustments, and cleaning/washing of each part are performed, including the main body removal/installation work and the replacement of defective parts.

	LON	DESCRIPTION	FRT
E	3112A0	CARBURETOR-OVERHAUL INCLUDES: All necessary adjustment	0.6

(5) Other work

	LON	DESCRIPTION	FRT
E	1101E1	ENGINE OIL-CHANGE INCLUDES: Engine oil-inspection	0.1

ENGINE GROUP

C13

E-2

CYLINDER HEAD

E 1

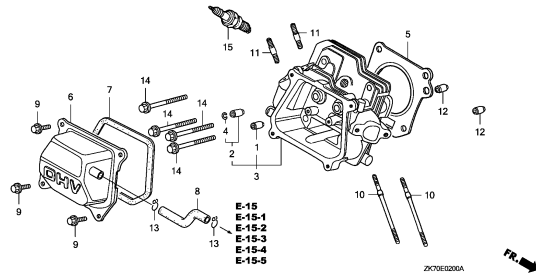

ZK70E0200A

E-3

CYLINDER BARREL

E 5

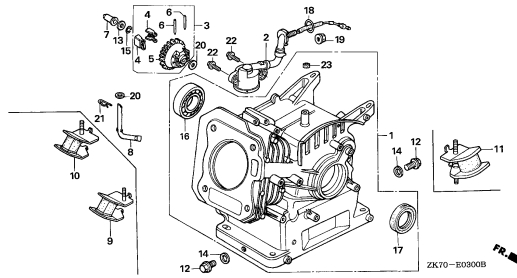

ZK70-E0300B

E-6

CRANKCASE COVER

E 7

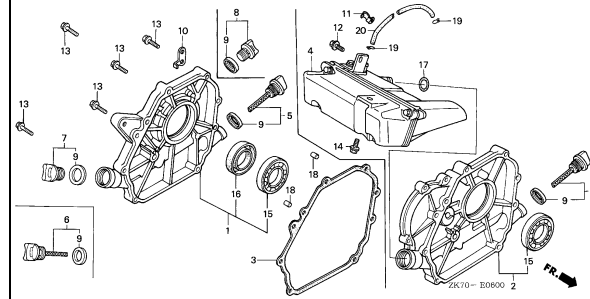

ZK70-E0600 2

E-7

CRANKSHAFT

E10

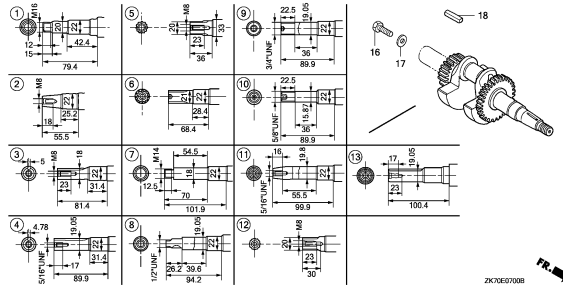

ZK70E0700B

E-8

PISTON/CONNECTING ROD

E12

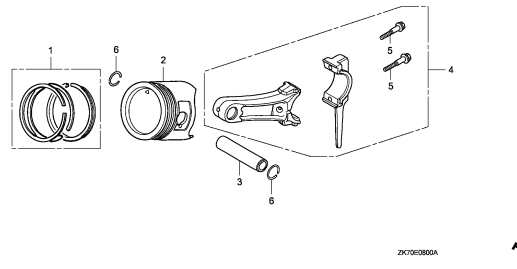

ZK70E0800A

E-9

CAMSHAFT

F 2

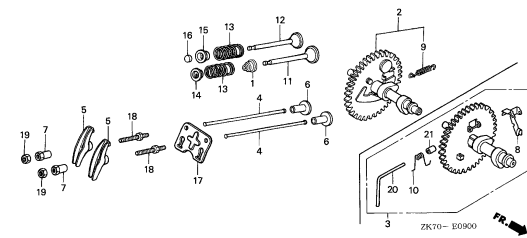

ZK70-E0900

E-11

RECOIL STARTER(1)

F 5

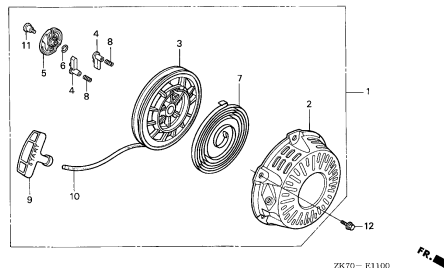

ZK70-E1100

E-11-1

RECOIL STARTER(2)

F10

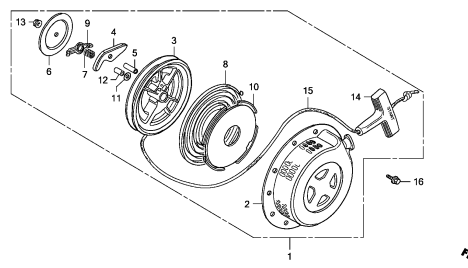

ZK70E1101A

E-11-2

RECOIL STARTER(3)

F11

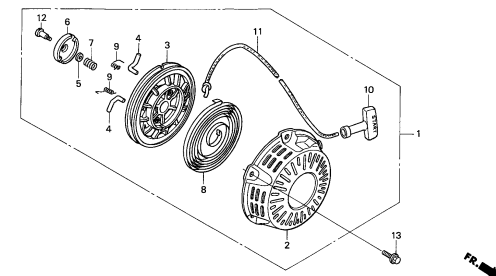

ZK70-E1102

2

ENGINE GROUP

C14

E-12

FAN COVER

G 1

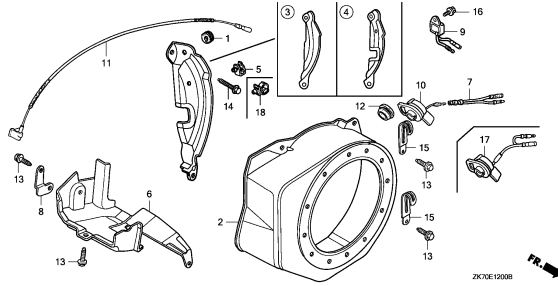

E-14

CARBURETOR(1)

G 5

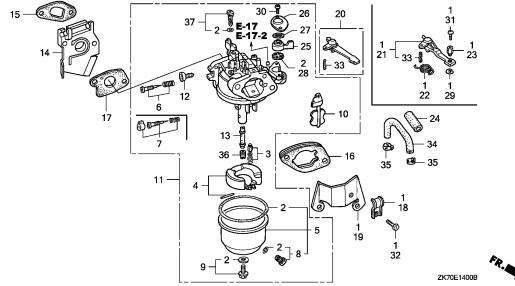

E-14-1

CARBURETOR(2)

G 8

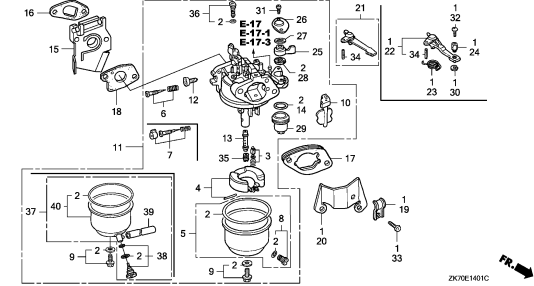

E-15

AIR CLEANER(1)

H 2

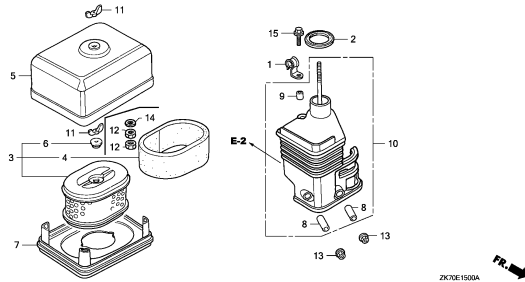

E-15-1

AIR CLEANER(2)

H 5

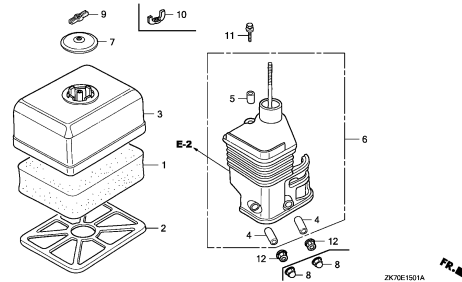

E-15-2

AIR CLEANER(3)

H 7

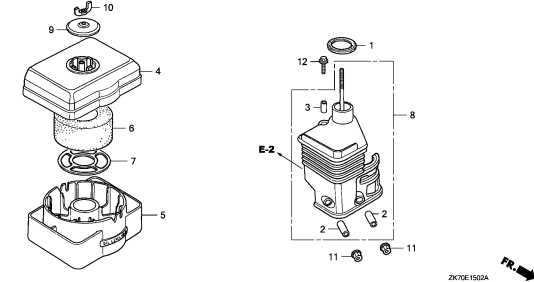

E-15-3

AIR CLEANER(4)

H 8

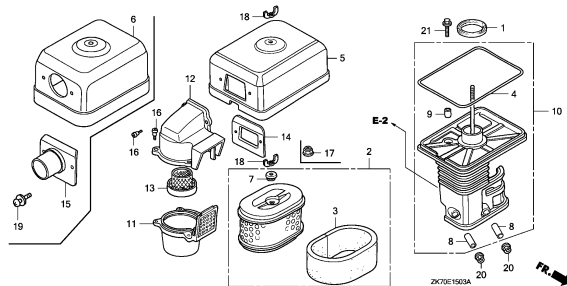

E-15-4

AIR CLEANER(5)

H10

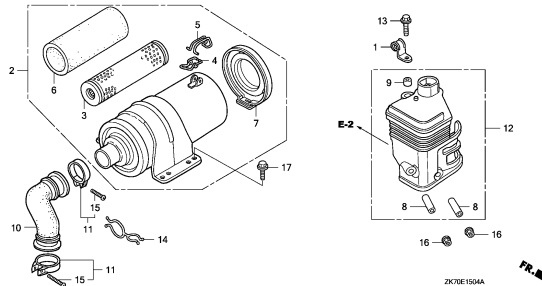

E-15-5

AIR CLEANER(6)

H11

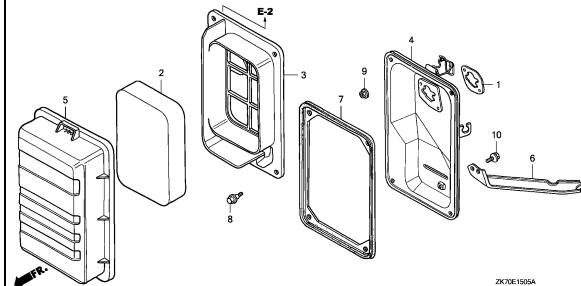

2

ENGINE GROUP

C15

E-16

MUFFLER(1)

H12

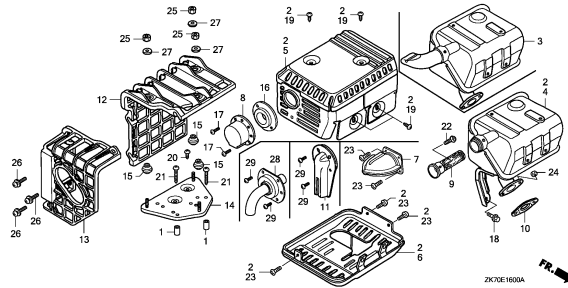

ZK70E1600A

E-16-1

MUFFLER(2)

H16

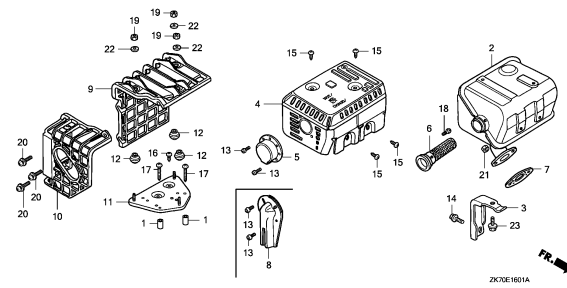

ZK70E1601A

E-16-2

MUFFLER(3)

I 2

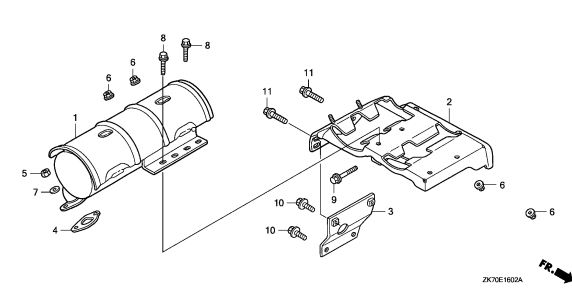

ZK70E1602A

E-16-3

MUFFLER(4)

I 3

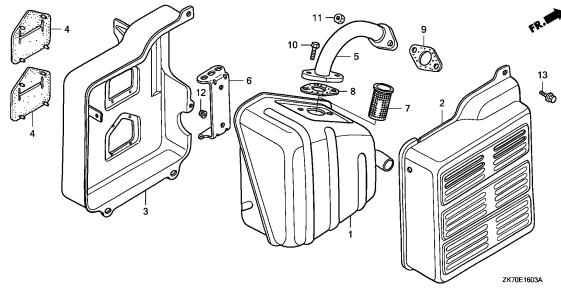

ZK70E1603A

E-17

FUEL TANK(1)

I 4

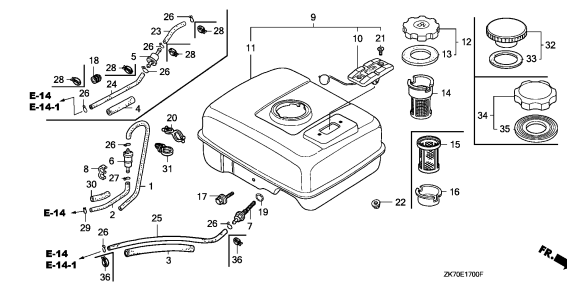

ZK70E1700F

E-17-1

FUEL TANK(2)

I 9

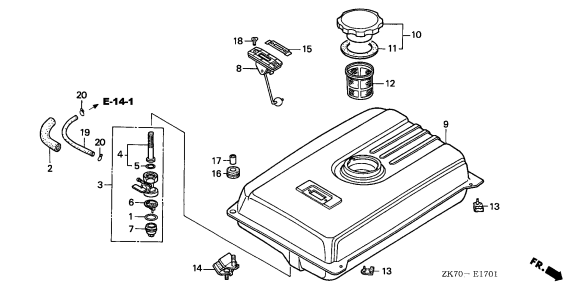

ZK70-E1701

E-17-2

FUEL TANK(3)

I10

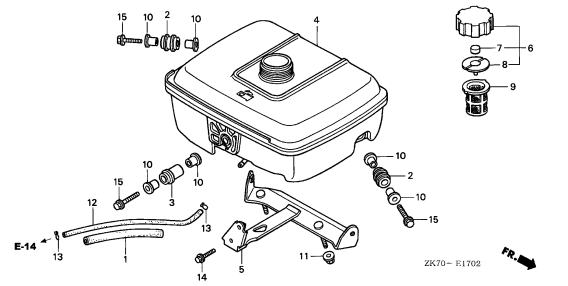

ZK70-E1702

E-17-3

FUEL TANK(4)

I11

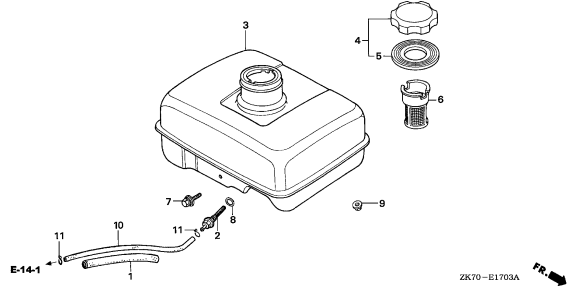

ZK70-E1703A

E-19

FLYWHEEL

I12

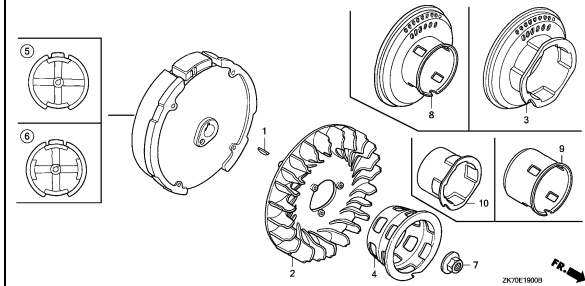

ZK70E1900A

2

ENGINE GROUP

C16

E-20

IGNITION COIL

I15

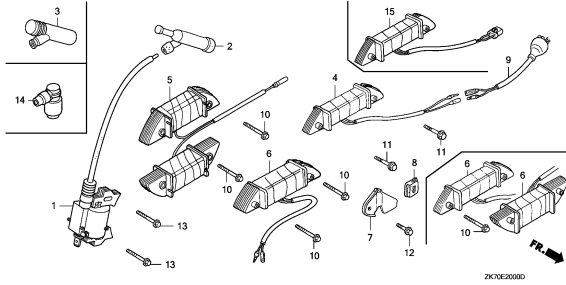

ZK70E2000B

E-22

CONTROL(1)

J 2

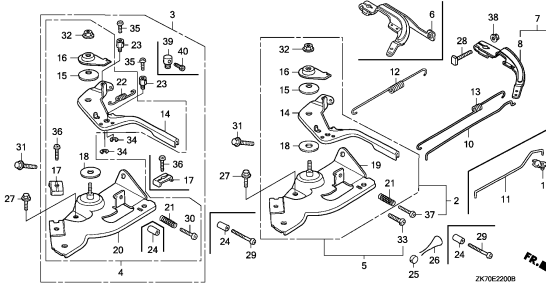

ZK70E2200B

E-22-1

CONTROL(2)

J10

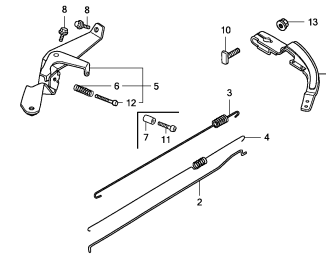

ZK70E2201A

E-22-2

CONTROL(3)

J11

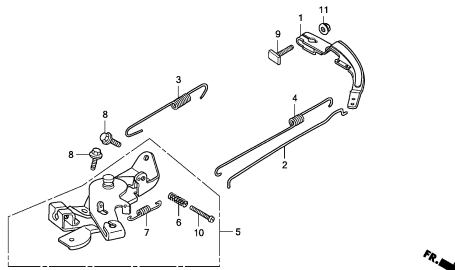

ZK70E2202B

E-22-3

CONTROL(4)

J12

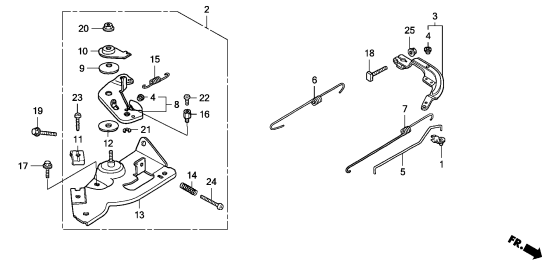

ZK70E2203A

E-26

REDUCTION(1)

J13

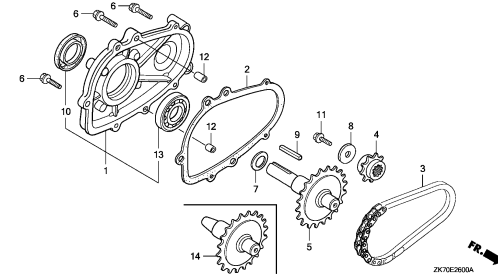

ZK70E2600A

E-26-1

REDUCTION(2)

J15

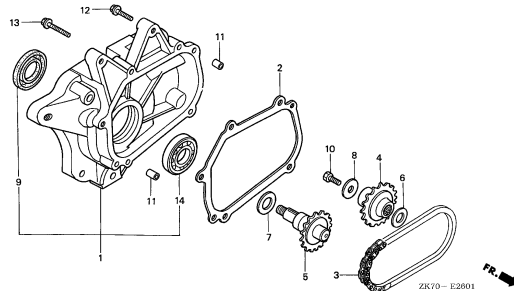

ZK70-E2601

E-26-2

REDUCTION(3)

J16

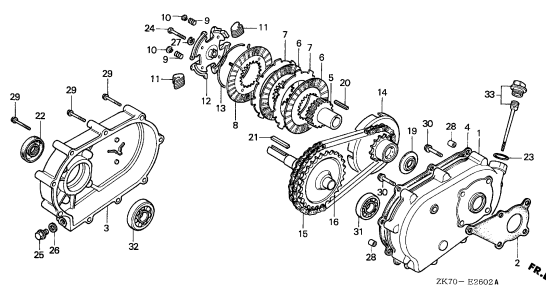

ZK70-E2602A

E-26-3

REDUCTION(4)

K 2

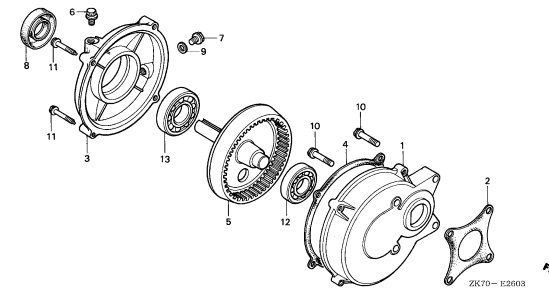

ZK70-E2603

2

ENGINE GROUP

D 1

E-28

LABEL

K 3

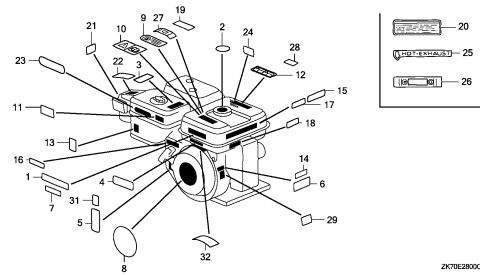

ZK70E2800C

E-29

TOOL

K 7

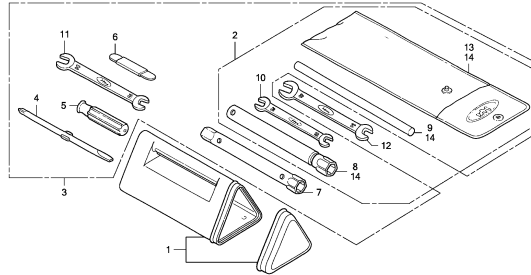

ZK70E2900A

E-30

TRANSMISSION

K 9

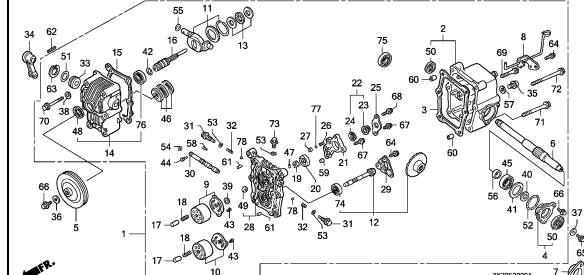

ZK70E3000A

E-31

OIL TANK

K13

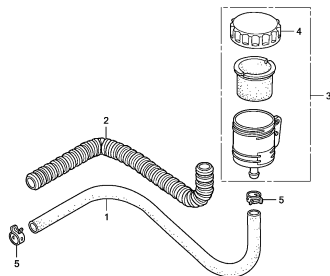

ZK70E3100A

E-40

OTHER PARTS(1)

K14

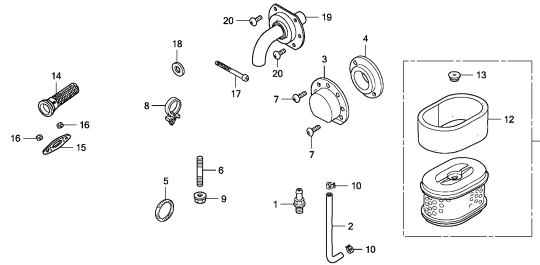

ZK70E4000D

E-40-1

OTHER PARTS(2)

K15

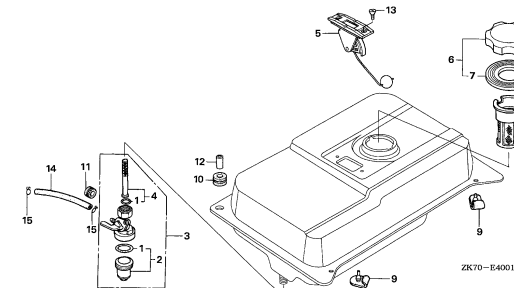

ZK70-E4001A

E-40-2

OTHER PARTS(3)

K16

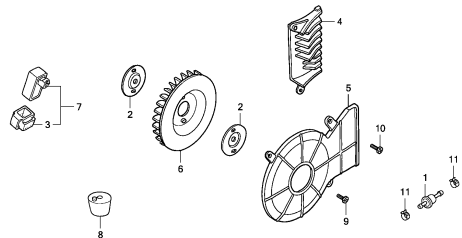

ZK70E4002A

E-40-3

OTHER PARTS(4)

L 1

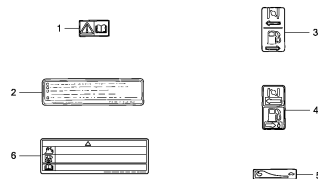

ZK70E4003A

EOP-1

GASKET KIT

L 2

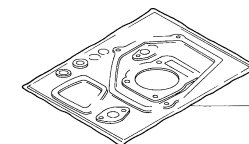

HENG-K0008

2

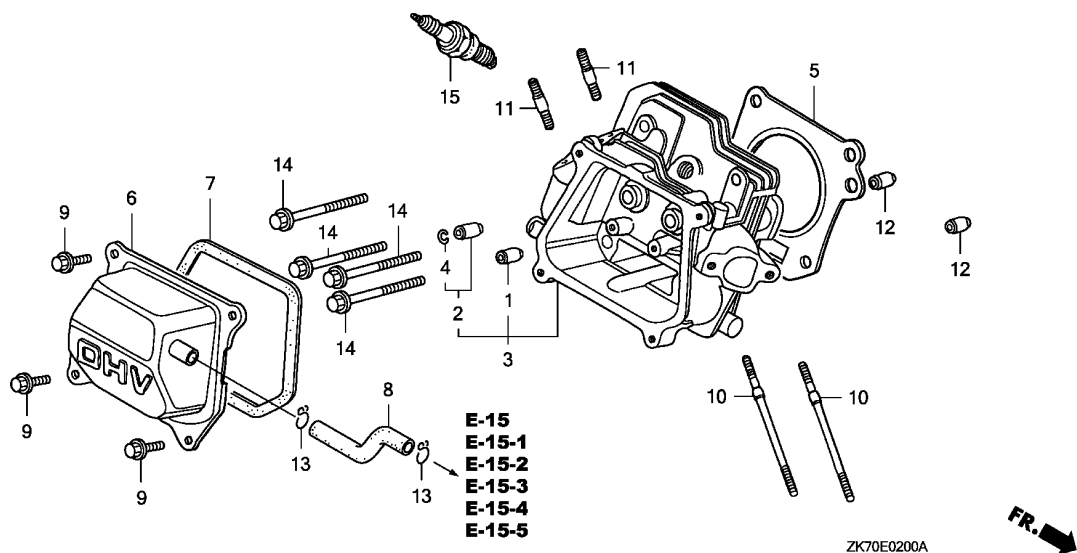

Ref. No.	L.O.N.	(Relative ref. Number) Description	F.R.T.
1	1111E9	GUIDE, INTAKE VALVEINCLUDES: Valve clearance adjustment	0.8
	1111E9E	.Replace intake and exhaust all add	0.4
2	1111E8	GUIDE, EXHAUST VALVEINCLUDES: Valve clearance adjustment	0.8
	1111E8E	.Replace intake and exhaust all add	0.4
3	1111N3	HEAD, CYLINDERINCLUDES: Valve clearance adjustment and reface	0.9
5	1111N4	GASKET, CYLINDER HEAD	0.5
6	1111D5	COVER, CYLINDER HEAD AND/OR PACKING, HEAD COVER	0.1
8	1111K5	TUBE, BREATHER	0.1
15	6141C1	PLUG, SPARKINCLUDES: Spark plug check	0.1

Ref. No.	Part No.	Description	Reqd. QTY				Serial No.	Parts catalogue code
			GX120K1 (1)	(2)	(3)	(4)		
1	12204-ZE1-306	GUIDE, IN. VALVE (O.S.)	(1)	(1)	(1)	(1)		
2	12205-ZE1-315	GUIDE, EX. VALVE (O.S.)	(1)	(1)	(1)	(1)		
3	12210-ZH7-405	HEAD COMP., CYLINDER	1	-	-	-	4516043	
			-	1	-	-	4516043	
			-	-	1	1	4516044	
	12210-ZH7-415	1	-	-	-	4516044	
			1	-	-	-	4516044	
			(1)	-	-	-	4516044	
			-	1	-	-	4516044	

E-2

CYLINDER HEAD



Ref. No.	Part No.	Description	Reqd. QTY				Serial No.	Parts catalogue code
			(1)	(2)	(3)	(4)		
4	12216-ZE5-300	CLIP, VALVE GUIDE	1	1	1	1		
5	12251-ZF0-000	GASKET, CYLINDER HEAD	-	-	1	-	----- SIH	
	12251-ZH7-800	1	(1)	-	1	----- WIH,WIS	
			-	-	1	-	-----	
6	12310-ZE1-000	COVER COMP., HEAD	-	-	1	-	----- 2533057 SIH,WIH	
	12310-ZE1-010	-	-	1	-	----- 2533058 SIH,WIH	
			-	-	-	1	----- QDBR,QXBR	
	12310-ZE1-020	1	-	1	1	----- AR,ARL,DKR,DS,HHQ4,HTF2,HT2,HT24,HX,HXU,HX2,HX26,HX4,KR,KRA4 KRF4,KRS4,KRS5,KRS6,KRT,KRT4,KRT6,LAJ,LAJ4,LD,LH,LHQ4,LJ,LJC LJC8,LJD2,LJS,LSJ,LSJ4,LTJ,LTJ1,LTR,LTS,LX,LXU,LX2,LX4,PX,PX2 QA,QA2,QB26,QD,QH,QHQ4,QH26,QJG2,QLL,QM,QMA4,QMA8,QME4,QMX2,QT QWA4,QX,QXS2,QXU,QX2,QX26,QX4,QX7,RD,RD4,RHC,RHQ4,RX,RX4,SAJ SAJ4,SAR4,SCJ,SD,SD16,SD4,SE,SG24,SH,SHQ4,SJ,SJC1,SJC5,SJD2 SKR,SMA7,SMJ,SMW2,SM11,SM12,SM14,SSK1,SSK3,SSX2,SSX4,SWX2,SWX4 SX,SXS4,SX4,SX7,SYA,TX,TXBR,TX2,TX26,TX4,UJU,VED,VED1,VED6 VEE1,VEK,VET,VEX,VEX7,VMS4,VMT,VPM4,VPR4,VSX,VSX1,VX,VXBR,VXU VX4,VX7,WDA6,WD12,WIS,WJ,WJP,WKD6,WKT2,WKT4,WKT6,WMA3,WMA4 WME2,WME4,WMK,WMI	
	12310-ZE1-842	COVER COMP., HEAD (BREATHER TUBE)	-	(1)	-	-	----- QXC9,STP,STS	
			1	-	-	-	-----	
			-	(1)	-	-	-----	
7	12391-ZE1-000	PACKING, HEAD COVER	1	1	1	1		
8	15721-ZE1-840	TUBE, BREATHER	1	-	-	-	----- QXC9,STP,STS	
			-	(1)	-	-	-----	
	15721-ZH8-000	1	-	-	-	----- AR,ARL,DKR,DS,HHQ4,HTF2,HT2,HT24,HX,HXU,HX2,HX26,HX4,KR,KRA4 KRF4,KRS4,KRS5,KRS6,KRT,KRT4,KRT6,LAJ,LAJ4,LD,LH,LHQ4,LJ,LJC LJC8,LJD2,LJS,LSJ,LSJ4,LTJ,LTJ1,LTR,LTS,LX,LXU,LX2,LX4,PX,PX2 QA,QA2,QB26,QD,QH,QHQ4,QH26,QJG2,QLL,QM,QMA4,QMA8,QME4,QMX2,QT QWA4,QX,QXS2,QXU,QX2,QX26,QX4,QX7,RD,RD4,RHC,RHQ4,RX,RX4,SAJ SAJ4,SAR4,SCJ,SD,SD16,SD4,SE,SG24,SH,SHQ4,SJ,SJC1,SJC5,SJD2 SKR,SMA7,SMJ,SMW2,SM11,SM12,SM14,SSK1,SSK3,SSX2,SSX4,SWX2,SWX4 SX,SXS4,SX4,SX7,SYA,TX,TX2,TX26,TX4,UJU,VED,VED1,VED6,VEE1,VEK VET,VEX,VEX7,VMS4,VSX,VSX1,VX,VXU,VX4,VX7,WDA6,WD12,WJ,WJP WKD6,WKT2,WKT4,WKT6,WMA3,WMA4,WME2,WME4,WMK,WMI	
	15721-883-030	-	(1)	1	1	----- VMT,VPM4,VPR4	
	90013-883-000	BOLT, FLANGE, 6X12(CT200) ...	4	4	4	4		
10	90043-ZB2-003	BOLT, STUD, 6X94	2	-	-	-	----- VMT,VPM4,VPR4	
	90043-ZE1-010	BOLT, STUD, 6X109	-	-	2	-	----- 2400125 SIH,WIH	
	90043-ZE1-020	BOLT, STUD, 6X112	2	-	2	-	----- AR,ARL,DKR,DS,HHQ4,HTF2,HT2,HT24,HX,HXU,HX2,HX26,HX4,KR,KRA4 KRF4,KRS4,KRS5,KRS6,KRT,KRT4,KRT6,LAJ,LAJ4,LD,LH,LHQ4,LJ,LJC LJC8,LJD2,LJS,LSJ,LSJ4,LTJ,LTJ1,LTR,LTS,LX,LXU,LX2,LX4,PX,PX2 QA,QA2,QB26,QD,QH,QHQ4,QH26,QJG2,QLL,QM,QMA4,QMA8,QME4,QMX2,QT QWA4,QX,QXC9,QXS2,QXU,QX2,QX26,QX4,QX7,RD,RD4,RHC,RHQ4,RX,RX4 SAJ,SAJ4,SAR4,SCJ,SD,SD16,SD4,SE,SG24,SH,SHQ4,SJ,SJC1,SJC5 SJD2,SKR,SMA7,SMJ,SMW2,SM11,SM12,SM14,SSK1,SSK3,SSX2,SSX4,STP STS,SWX2,SWX4,SX,SXS4,SX4,SX7,SYA,TX,TX2,TX26,TX4,UJU,VED,VED1 VED6,VEE1,VEK,VET,VEX,VEX7,VMS4,VSX,VSX1,VX,VXU,VX4,VX7,WDA6 WD12,WIS,WJ,WJP,WKD6,WKT2,WKT4,WKT6,WMA3,WMA4,WME2,WME4,WMK WMI	
			-	2	-	2	-----	
			-	-	2	-	----- 2400126 SIH,WIH	
11	90047-ZE1-000	BOLT, STUD, 8X32	2	2	2	2		
12	94301-10160	DOWEL PIN, 10X16	2	2	2	2		



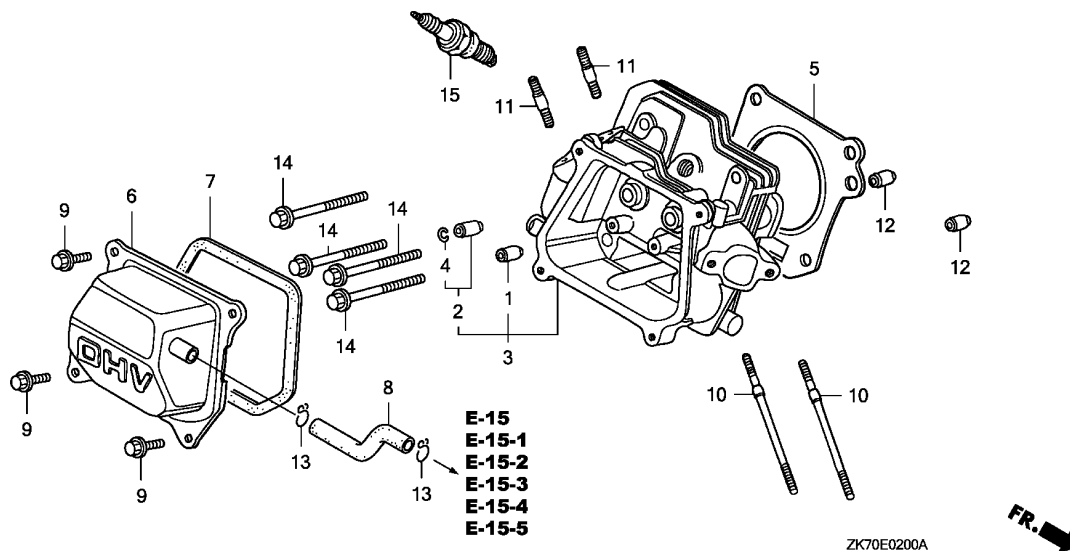

E-15
E-15-1
E-15-2
E-15-3
E-15-4
E-15-5

ZK70E0200A



Ref. No.	Part No.	Description	Reqd. QTY				Serial No.	Parts catalogue code	
			(1)	(2)	(3)	(4)			
13	95002-80000	CLIP, TUBE (C12)	2	-	-	-	-----	QXC9,STP,STS	
14	95723-08055-00	BOLT, FLANGE, 8X55	4	-	-	-	-----	AR,ARL,DKR,HHQ4,HTF2,HT2,HT24,HXU,HX2,HX26,HX4,KRA4,KRF4,KRS4,KRS5,KRS6,KRT4,LAJ4,LHQ4,LJD2,LSJ4,LXU,LX2,LX4,PX2,QA2,QHQ4,QH26,QJG2,QLL,QMA4,QMA8,QME4,QMX2,QWA4,QXC9,QXS2,QXU,QX2,QX26,QX4,QX7,RD4,RHC,RHQ4,RX4,SAJ4,SAR4,SD16,SD4,SE,SG24,SHQ4,SJD2,SMA7,SMW2,SM12,SM14,SSX2,SSX4,SWX2,SWX4,SXS4,SX4,SX7,TX2,TX26,TX4,UXU,VED6,VEX,VEX7,VMS4,VPM4,VPR4,VXU,VX4,VX7,WDA6,WD12,WKD6,WKT2,WKT4,WKT6,WMA3,WMA4,WME2,WME4	
			4	-	-	-	4532609	DS,HX,KR,KRT,KRT6,LAJ,LD,LH,LJ,LJC,LJC8,LJS,LSJ,LTJ,LTK1,LTR,LTS,LX,PX,QA,QB26,QD,QH,QM,QT,QX,RD,RX,SAJ,SCJ,SD,SH,SJ,SJC1,SJC5,SKR,SMJ,SM11,SSK1,SSK3,STP,STS,SX,SYA,TX,VED,VED1,VEE1,VEK,VET,VMT,VSX,VSX1,VX,WJ,WJP,WMK,WM1	
	95701-08055-00	4	-	4	4	4532610	DS,HX,KR,KRT,KRT6,LAJ,LD,LH,LJ,LJC,LJC8,LJS,LSJ,LTJ,LTK1,LTR,LTS,LX,PX,QA,QB26,QD,QH,QM,QT,QX,RD,RX,SAJ,SCJ,SD,SH,SJ,SJC1,SJC5,SKR,SMJ,SM11,SSK1,SSK3,STP,STS,SX,SYA,TX,VED,VED1,VEE1,VEK,VET,VMT,VSX,VSX1,VX,WJ,WJP,WMK,WM1	
15	98079-54841	PLUG, SPARK (BP4ES) (NGK)	1	-	-	-	4532610	-----	KRT6
	98079-54846	PLUG, SPARK (BPR4ES) (NGK) ...	1	-	-	-	-----	-----	AR,ARL,DKR,KR,KRA4,KRF4,KRS4,KRS5,KRS6,KRT,KRT4
	98079-54854	PLUG, SPARK (W14EP-U) (DENSO)	1	-	-	-	-----	-----	KRT6
	98079-54855	PLUG, SPARK (W14EPR-U) (DENSO)	1	-	-	-	-----	-----	AR,ARL,DKR,KR,KRA4,KRF4,KRS4,KRS5,KRS6,KRT,KRT4
	98079-55841	PLUG, SPARK (BP5ES) (NGK)	1	-	1	-	-----	-----	VEK,WIH
			-	(1)	-	-			

Ref. No.	Part No.	Description	Reqd. QTY				Serial No.	Parts catalogue code
			(1)	GX120K1 (2)	(3)	(4)		
15)	98079-55846	PLUG, SPARK (BPR5ES) (NGK) ...	1	-	-	-	HX4, LAJ4, LHQ4, LSJ4, LTR, LX4, QB26, QHQ4, QJG2, QX4, QX7, RD4, RHQ4, SD4, TX4, WD12, WKT4, WMA3, WME4, WM1	
			(1)	-	-	(1)	HTF2, HT2, HT24, HX, HXU, HX2, HX26, LH, LJC8, LJD2, LX, LXU, LX2, PX, PX2, QA, QA2, QH, QH26, QLL, QME4, QMX2, QX, QXBR, QXU, QX2, QX26, RHC, SG24, SJD2, SMW2, SM11, SM14, SWX2, SWX4, TX, TXBR, TX2, TX26, VED, WDA6, WKD6, WKT2, WKT6, WMA4, WME2, WMK	
	98079-55854	PLUG, SPARK (W16EP-U) (DENSO)	1	-	1	-	VEK, WIH	
	98079-55855	PLUG, SPARK (W16EPR-U) (DENSO)	1	-	-	-	HX4, LAJ4, LHQ4, LSJ, LSJ4, LTR, LTS, LX4, QB26, QHQ4, QJG2, QMA4, QMA8, QWA4, QX4, QX7, RD4, RHQ4, SAJ4, SD4, SHQ4, SJC5, SKR, SMA7, SM12, SXS2, SXS4, TX4, UXU, VEE1, VEK, VEX7, VMS4, VMT, VPR4, VXU, WD12, WKT4, WMA3, WME4, WM1	
			(1)	-	-	(1)	HHQ4, HTF2, HT2, HT24, HX, HXU, HX2, HX26, LH, LJC8, LJD2, LX, LXU, LX2, PX, PX2, QA, QA2, QH, QH26, QLL, QME4, QMX2, QX, QXBR, QXU, QX2, QX26, RHC, RX4, SG24, SJD2, SMW2, SM11, SM14, SWX2, SWX4, SX4, SX7, TX, TXBR, TX2, TX26, VED, VX4, VX7, WDA6, WKD6, WKT2, WKT6, WMA4, WME2, WMK	
	98079-56841	PLUG, SPARK (BP6ES) (NGK)	1	-	-	-	LJC, LTK1, QM, STP, STS, VSX, VSX1	
	98079-56846	PLUG, SPARK (BPR6ES) (NGK) ...	1	-	-	-	DS, HTF2, HT2, HT24, HX, HXU, HX2, HX26, LAJ, LAJ4, LD, LH, LJ, LJC8, LJD2, LJS, LSJ, LSJ4, LTJ, LTS, LX, LXU, LX2, PX, PX2, QA, QA2, QB26, QD, QH, QHQ4, QH26, QJG2, QLL, QMA4, QMA8, QME4, QMX2, QWA4, QX, QXC9, QXS2, QXU, QX2, QX26, RD, RHC, RX, SAJ, SAJ4, SAR4, SCJ, SD, SD16, SE, SG24, SH, SHQ4, SJ, SJC1, SJC5, SJD2, SKR, SMA7, SMJ, SMW2, SM11, SM12, SM14, SSK1, SSK3, SXS2, SXS4, SWX2, SWX4, SX, SXS4, SYA, TX, TX2, TX26, UXU, VED, VED1, VED6, VEE1, VEK, VET, VEX, VEX7, VMS4, VMT, VPM4, VPR4, VX, VXU, WDA6, WD12, WJ, WJP, WKD6, WKT2, WKT4, WKT6, WMA3, WMA4, WME2, WME4, WMK, WM1	
			(1)	-	-	-	HHQ4, HX4, LHQ4, LX4, QX4, QX7, RD4, RHQ4, RX4, SD4, SX4, SX7, TX4, VX4, VX7	
	98079-56854	PLUG, SPARK (W20EP-U) (DENSO)	1	-	-	-	LJC, LTK1, QM, QT, STP, STS, VSX, VSX1	
	98079-56855	PLUG, SPARK (W20EPR-U) (DENSO)	1	-	-	-	DS, HTF2, HT2, HT24, HX, HX2, HX26, LAJ, LD, LH, LJ, LJC8, LJS, LTJ, LX, LX2, PX, PX2, QA, QA2, QD, QH, QH26, QLL, QMX2, QX, QXC9, QXS2, QX2, QX26, RD, RHC, RX, SAJ, SAR4, SCJ, SD, SD16, SE, SG24, SH, SJ, SJC1, SMJ, SMW2, SSK1, SSK3, SXS4, STS, SWX2, SWX4, SX, SYA, TX, TX2, TX26, VED1, VED6, VET, VEX, VPM4, VX, WDA6, WJ, WJP, WKD6, WKT2, WMA4, WME2, WMK	
			-	(1)	-	1		

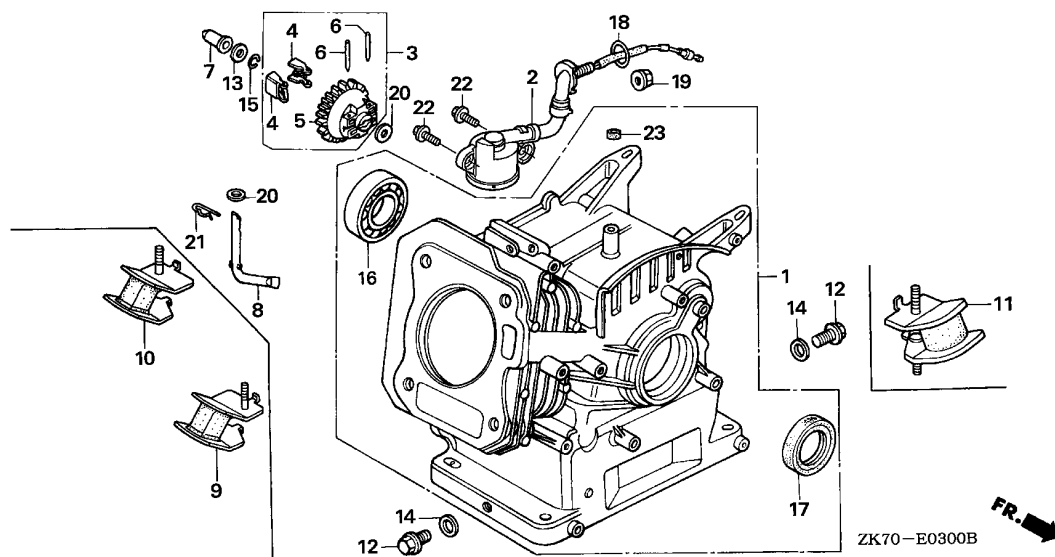

Ref. No.	L.O.N.	(Relative ref. Number) Description	F.R.T.
1	1101A0	BARREL, CYLINDER	2.0
2		(18)	
	6151E8	SWITCH, OIL LEVEL	0.5
3	1161C4	GOVERNOR ASSEMBLY	0.9
5		(4,6)	
	1161A7	HOLDER, GOVERNOR WEIGHT	1.0
7	1161B6	SLIDER, GOVERNOR	0.4
8	1161B4	SHAFT, GOVERNOR ARM	0.9
14	1101D5	WASHER, DRAIN PLUG	0.1
16	1101A4	BEARING, CRANKSHAFT :FRONT ...	1.3
17	1101E4	OIL SEAL, CRANKSHAFT :FRONT ..	1.2
23	1101C4	OIL SEAL, GOVERNOR ARM SHAFT ..	0.9

Ref. No.	Part No.	Description	Reqd. QTY				Serial No.	Parts catalogue code
			(1)	(2)	(3)	(4)		
1	12000-ZF0-425	BARREL ASSY., CYLINDER	1	-	-	1	-----	AR,ARL,DKR,DS,HHQ4,HT2,HT24,KR,KRA4,KRF4,KRS4,KRT,KRT4,KRT6 LAJ,LAJ4,LD,LH,LHQ4,LJ,LJD2,LJS,LSJ,LSJ4,LTJ,LTK1,LTR,LTS,QA QA2,QB26,QD,QDBR,QH,QHQ4,QH26,QJG2,QM,QMA4,QME4,QT,RD,RD4,RHC RHQ4,SAJ,SAJ4,SAR4,SCJ,SD,SD16,SD4,SE,SH,SHQ4,SJ,SJD2,SKR,SM11 SSK1,SSK3,STP,STS,SYA,VED,VEK,VET,WDA6,WD12,WJ,WJP,WMA3,WMA4 WME4,WMK,WM1
	12000-ZH7-425	-	(1)	1	-	-----	HTF2,HX,HXU,HX2,HX26,HX4,LJC,LJC8,LX,LXU,LX2,LX4,PX,PX2,QLL QMA8,QMX2,QWA4,QX,QXBR,QXC9,QXS2,QXU,QX2,QX26,QX4,QX7,RX,RX4 SG24,SJC1,SJC5,SMA7,SMJ,SMW2,SM12,SM14,SSX2,SSX4,SWX2,SWX4,SX SXS4,SX4,SX7,TX,TXBR,TX2,TX26,TX4,UXU,VED1,VED6,VEE1,VEX,VEX7 VMS4,VMT,VPM4,VPR4,VSX,VSX1,VX,VXBR,VXU,VX4,VX7,WKD6,WKT2,WKT4 WKT6,WME2
	12000-ZK7-405	-	(1)	-	-	-----	KRS5,KRS6
2	15510-ZE1-033	SWITCH ASSY., OIL LEVEL	1	(1)	-	1	-----	HTF2,HXU,HX2,HX26,HX4,LX,LXU,LX2,LX4,PX,PX2,QLL,QMA8,QMX2,QWA4 QXBR,QXC9,QXS2,QXU,QX2,QX26,QX4,QX7,RX4,SG24,SMA7,SMW2,SM12 SM14,SSX2,SSX4,SWX2,SWX4,SXS4,SX4,SX7,TX,TXBR,TX2,TX26,TX4,UXU VED1,VED6,VEE1,VEX,VEX7,VMS4,VMT,VPM4,VPR4,VX,VXBR,VXU,VX4,VX7 WKD6,WKT2,WKT4,WKT6,WME2,W1
	15510-ZE1-043	1	(1)	-	-	4572370	HX,H1,LJC,LJC8,L1,QX,Q1,RX,R1,SJC1,SJC5,SMJ,SX,S1,VSX,VSX1
3	16510-ZE1-000	GOVERNOR ASSY.	1	(1)	-	1	4572371	HX,H1,LJC,LJC8,L1,QX,Q1,RX,R1,SJC1,SJC5,SMJ,SX,S1,VSX,VSX1
4	16511-ZE1-000	WEIGHT, GOVERNOR	1	1	1	1		
5	16512-ZE1-000	HOLDER, GOVERNOR WEIGHT	2	2	2	2		
	16513-ZE1-000	PIN, GOVERNOR WEIGHT	1	1	1	1		
7	16531-ZE1-000	SLIDER, GOVERNOR	1	1	1	1		
8	16541-ZE1-000	SHAFT, GOVERNOR ARM	1	1	1	1		

Ref. No.	Part No.	Description	Reqd. QTY				Serial No.	Parts catalogue code
			(1)	GX120K1 (2)	(3)	(4)		
9	68326-ZB2-000	RUBBER, FR. BOTTOM	2	-	-	-	VSX, VSX1	
10	68327-ZB2-000	RUBBER, RR. BOTTOM	2	-	-	-	VSX, VSX1	
11	68328-ZB2-000	RUBBER, BOTTOM	4	-	-	-	VET	
12	90131-ZE1-000	BOLT, DRAIN PLUG	2	2	2	2		
13	90451-ZE1-000	WASHER, THRUST, 6MM	1	(1)	1	1		
14	90601-ZE1-000	WASHER, DRAIN PLUG, 10.2MM ..	2	2	2	2		
15	90602-ZE1-000	CLIP, GOVERNOR HOLDER	1	1	1	1		
16	91001-878-003	BEARING, RADIAL BALL, 62/22 ..	1	(1)	1	1		
17	91202-ZE6-013	OIL SEAL, 22X35X6	1	(1)	1	1		
18	91353-671-004	O-RING, 14MM(NOK)	1	-	-	1	HTF2, HX, HXU, HX2, HX26, HX4, LJC, LJC8, LX, LXU, LX2, LX4, PX, PX2, QLL, QMA8, QMX2, QWA4, QX, QXBR, QXC9, QXS2, QXU, QX2, QX26, QX4, QX7, RX, RX4, SG24, SJC1, SJC5, SMA7, SMJ, SMW2, SM12, SM14, SSX2, SSX4, SWX2, SWX4, SX, SXS4, SX4, SX7, TX, TXBR, TX2, TX26, TX4, UXU, VED1, VED6, VEE1, VEX, VEX7, VMS4, VMT, VPM4, VPR4, VSX, VSX1, VX, VXBR, VXU, VX4, VX7, WKD6, WKT2, WKT4, WKT6, WME2	
19	94050-10000	NUT, FLANGE, 10MM	1	(1)	-	-	HTF2, HX, HXU, HX2, HX26, HX4, LJC, LJC8, LX, LXU, LX2, LX4, PX, PX2, QLL, QMA8, QMX2, QWA4, QX, QXBR, QXC9, QXS2, QXU, QX2, QX26, QX4, QX7, RX, RX4, SG24, SJC1, SJC5, SMA7, SMJ, SMW2, SM12, SM14, SSX2, SSX4, SWX2, SWX4, SX, SXS4, SX4, SX7, TX, TXBR, TX2, TX26, TX4, UXU, VED1, VED6, VEE1, VEX, VEX7, VMS4, VMT, VPM4, VPR4, VSX, VSX1, VX, VXBR, VXU, VX4, VX7, WKD6, WKT2, WKT4, WKT6, WME2	
20	94101-06800	WASHER, PLAIN, 6MM	2	(1)	-	-		
21	94251-08000	PIN, LOCK, 8MM	1	1	1	1		
22	95701-06012-00	BOLT, FLANGE, 6X12	2	-	-	2	HTF2, HX, HXU, HX2, HX26, HX4, LJC, LJC8, LX, LXU, LX2, LX4, PX, PX2, QLL, QMA8, QMX2, QWA4, QX, QXBR, QXC9, QXS2, QXU, QX2, QX26, QX4, QX7, RX, RX4, SG24, SJC1, SJC5, SMA7, SMJ, SMW2, SM12, SM14, SSX2, SSX4, SWX2, SWX4, SX, SXS4, SX4, SX7, TX, TXBR, TX2, TX26, TX4, UXU, VED1, VED6, VEE1, VEX, VEX7, VMS4, VMT, VPM4, VPR4, VSX, VSX1, VX, VXBR, VXU, VX4, VX7, WKD6, WKT2, WKT4, WKT6, WME2	
23	91231-891-003	OIL SEAL, 6X11X4(ARAI)	1	(2)	-	-	KRS5, KRS6	

E-6

CRANKCASE COVER

E 7

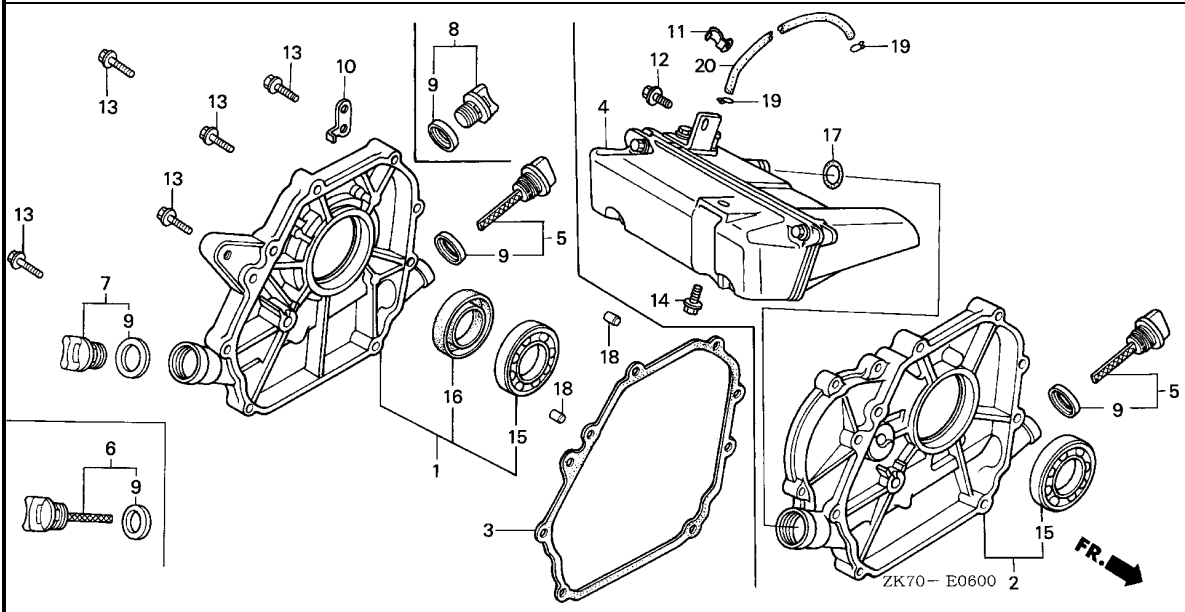

Ref. No.	L.O.N.	(Relative ref. Number) Description	F.R.T.
1		(2)	
1101F1		COVER, CRANKCASE	0.3
3	1101E9	PACKING, CRANKCASE COVER	0.3
4	1171B4	TANK, CRANKCASE COVER OIL	0.2
15	1101A6	BEARING, CRANKSHAFT :REAR	0.4
16	1101E5	OIL SEAL, CRANKSHAFT :REAR	0.3
20	1171A7	TUBE, OIL TANK	0.1

Ref. No.	Part No.	Description	Reqd. QTY				Serial No.	Parts catalogue code
			(1)	GX120K1 (2)	(3)	(4)		
1	11300-ZE0-634	COVER ASSY., CRANKCASE	1	1	1	-	HHQ4,HTF2,HT2,HT24,HX,HXU,HX2,HX26,HX4,H1,SAJ,SAJ4,SAR4,SCJ,SD SD16,SD4,SE,SG24,SH,SHQ4,SJ,SJC1,SJC5,SKR,SMA7,SMJ,SMW2,SM11 SM12,SM14,SSK1,SSK3,SSX2,SSX4,STP,STS,SX,SXS4,SX4, SX7,SYA,S1 VED,VED1,VED6,VEE1,VET,VMT,VSX,VSX1,WDA6,WD12,WIH,WIS,WJ,WJP WKD6,WKT2,WKT4,WKT6,WMA3,WMA4,WME2,WME4,WMK,WM1,W1	
	11300-ZE0-641	1	1	-	-	PX,PX2,QA,QA2,QB26,QD,QH,QHQ4,QH26,QJG2,QLL,QM,QMA4,QMA8,QME4 QMX2,QT,QWA4,QX,QXC9,QXS2,QXU,QX2,QX26,QX4,QX7,Q1,TX,TX2,TX26 TX4,UXU,VEX,VEX7,VMS4,VPM4,VPR4,VX,VXU,VX4,VX7	
	11300-ZE0-010	-	-	-	1	RD,RD4,RHC,RHQ4,RX,RX4,R1,SIH,SJD2,SWX2,SWX4,VEK	
2	11300-ZE0-613	COVER ASSY., CRANKCASE	1	1	-	-	DS,LAJ,LAJ4,LD,LH,LHQ4,LJ,LJC,LJC8,LJD2,LJS,LSJ,LSJ4,LTJ,LTK1 LTR,LTS,LX,LXU,LX2,LX4,L1	
	11300-ZK7-V00	1	-	-	-	AR,ARL,DKR,KR,KRA4,KRF4,KRS4,KRS5,KRS6	
	11300-ZK7-V20	1	-	-	-	KRT,KRT4	
	11300-ZK7-W20	1	-	-	-	KRT6	
3	11381-ZH7-800	PACKING, CASE COVER	1	-	-	-	DS,HHQ4,HTF2,HT2,HT24,HX,HXU,HX2,HX26,HX4,KRT,KRT4,LAJ,LAJ4,LD LH,LHQ4,LJ,LJC,LJC8,LJD2,LJS,LSJ,LSJ4,LTJ,LTK1, LTR,LTS,LX,LXU,LX2,LX4,L1 LX2,LX4,PX,PX2,QA,QA2,QB26,QD,QH,QHQ4,QH26,QJG2,QLL,QM,QMA4 QMA8,QME4,QMX2,QT,QWA4,QX,QXC9,QXS2,QXU,QX2,QX26,QX4,QX7, RD RD4,RHC,RHQ4,RX,RX4,SAJ,SAJ4,SAR4,SCJ,SD,SD16,SD4,SE,SG24,SH SHQ4,SJ,SJC1,SJC5,SJD2,SKR,SMA7,SMJ,SMW2,SM11,SM12,SM14,SSK1 SSK3,SSX2,SSX4,STP,STS,SWX2,SWX4,SX,SXS4,SX4, SX7,SYA,TX,TX2 TX26,TX4,UXU,VED,VED1,VED6,VEE1,VEK,VET,VEX,VEX7,VMS4,VMT,VPM4 VPR4,VSX,VSX1,VX,VXU,VX4,VX7,WDA6,WD12,WJ,WJP,WKD6,WKT2,WKT4 WKT6,WMA3,WMA4,WME2,WME4,WMK,WM1	
	11381-ZK7-V00	-	1	1	1	AR,ARL,DKR,KR,KRA4,KRF4,KRS4,KRS5,KRS6	
	11381-ZK7-W20	1	-	-	-	KRT6	
4	15500-ZK7-V00	TANK ASSY., OIL	1	-	-	-	AR,ARL,DKR,KR,KRA4,KRF4,KRS4,KRS5,KRS6,KRT,KRT4,KRT6	

2

Ref. No.	Part No.	Description	Reqd. QTY				Serial No.	Parts catalogue code	
			(1)	GX120K1 (2)	(3)	(4)			
5	15600-ZE1-003	CAP ASSY., OIL FILLER (GRAY)	1	-	-	-	AR, ARL, DKR, DS, HHQ4, HTF2, HT2, HT24, HX, HXU, HX2, HX26, HX4, KR, KRA4, KRF4, KRS4, KRS5, KRS6, KRT, KRT4, KRT6, LAJ, LAJ4, LD, LH, LHQ4, LJ, LJC, LJ8, LJD2, LJS, LSJ, LSJ4, LTJ, LTK1, LTR, LTS, LX, LXU, LX2, LX4, PX, PX2, QA, QA2, QB26, QD, QH, QHQ4, QH26, QJG2, QLL, QMA4, QMA8, QME4, QMX2, QWA4, QX, QXC9, QXS2, QXU, QX2, QX26, QX4, QX7, RD, RD4, RHC, RHQ4, RX, RX4, SAJ, SAJ4, SAR4, SCJ, SD, SD16, SD4, SE, SG24, SH, SHQ4, SJ, SJC1, SJC5, SJD2, SKR, SMA7, SMJ, SMW2, SM11, SM12, SM14, SSK1, SSK3, SSS2, SSS4, STP, STS, SX, SXS4, SX4, SX7, TX, TX2, TX26, TX4, UXU, VED, VED1, VED6, VEE1, VEK, VET, VEX, VEX7, VMS4, VMT, VPM4, VPR4, VSX, VSX1, VX, VXU, VX4, VX7, WDA6, WD12, WJ, WJP, WKD6, WKT2, WKT4, WKT6, WMA3, WMA4, WME2, WME4, WMK, WM1	4505099	SYA
			1	-	-	-			
	15600-ZF0-003	CAP ASSY., OIL FILLER	1	-	-	1	QM, QT		
			-	-	1	-			
	15600-ZE1-003	CAP ASSY., OIL FILLER (GRAY)	1	-	-	-	4549894	SYA	
6	15600-ZE1-003	CAP ASSY., OIL FILLER (GRAY)	1	-	-	-	SMJ, SWX2, SWX4		
			1	-	-	-	4505100	SYA	
7	15600-ZG4-003	CAP ASSY., OIL FILLER	1	-	-	-	DS, HHQ4, HTF2, HT2, HT24, HX, HXU, HX2, HX26, HX4, LAJ, LAJ4, LD, LH, LHQ4, LJ, LJC, LJ8, LJD2, LJS, LSJ, LSJ4, LTJ, LTK1, LTR, LTS, LX, LXU, LX2, LX4, PX, PX2, QA, QA2, QB26, QD, QH, QHQ4, QH26, QJG2, QLL, QM, QMA4, QMA8, QME4, QMX2, QT, QWA4, QX, QXC9, QXS2, QXU, QX2, QX26, QX4, QX7, RD, RD4, RHC, RHQ4, RX, RX4, SAJ, SAJ4, SAR4, SCJ, SD, SD16, SD4, SE, SG24, SH, SHQ4, SJ, SJC1, SJC5, SJD2, SKR, SMA7, SMJ, SMW2, SM11, SM12, SM14, SSK1, SSK3, SSS2, SSS4, STP, STS, SX, SXS4, SX4, SX7, TX, TX2, TX26, TX4, UXU, VED, VED1, VED6, VEE1, VEK, VET, VEX, VEX7, VMS4, VMT, VPM4, VPR4, VSX, VSX1, VX, VXU, VX4, VX7, WDA6, WD12, WJ, WJP, WKD6, WKT2, WKT4, WKT6, WMA3, WMA4, WME2, WME4, WMK, WM1	4505099	SYA
			1	-	-	-			
			-	1	1	1			
8	15600-ZG4-003	CAP ASSY., OIL FILLER	1	-	-	-	SWX2, SWX4		
			1	-	-	-	4505100	4549893	
9	15625-ZE1-003	PACKING, OIL FILLER CAP	1	-	-	-	AR, ARL, DKR, KR, KRA4, KRF4, KRS4, KRS5, KRS6, KRT, KRT4, KRT6		
			2	-	-	-	DS, HHQ4, HTF2, HT2, HT24, HX, HXU, HX2, HX26, HX4, LAJ, LAJ4, LD, LH, LHQ4, LJ, LJC, LJ8, LJD2, LJS, LSJ, LSJ4, LTJ, LTK1, LTR, LTS, LX, LXU, LX2, LX4, PX, PX2, QA, QA2, QB26, QD, QH, QHQ4, QH26, QJG2, QLL, QM, QMA4, QMA8, QME4, QMX2, QT, QWA4, QX, QXC9, QXS2, QXU, QX2, QX26, QX4, QX7, RD, RD4, RHC, RHQ4, RX, RX4, SAJ, SAJ4, SAR4, SCJ, SD, SD16, SD4, SE, SG24, SH, SHQ4, SJ, SJC1, SJC5, SJD2, SKR, SMA7, SMJ, SMW2, SM11, SM12, SM14, SSK1, SSK3, SSS2, SSS4, STP, STS, SWX2, SWX4, SX, SXS4, SX4, SX7, SYA, TX, TX2, TX26, TX4, UXU, VED, VED1, VED6, VEE1, VEK, VET, VEX, VEX7, VMS4, VMT, VPM4, VPR4, VSX, VSX1, VX, VXU, VX4, VX7, WDA6, WD12, WJ, WJP, WKD6, WKT2, WKT4, WKT6, WMA3, WMA4, WME2, WME4, WMK, WM1		
10	32302-734-K50	STAY, CORD CLIP (B)	-	2	2	2	VEK		
			1	-	-	-			
11	35210-MA6-000	CLAMP, SWITCH CORD	1	-	-	-	KRT, KRT4, KRT6		
12	90014-952-000	BOLT, FLANGE, 6X14(CT200) ...	1	-	-	-	AR, ARL, DKR, KR, KRA4, KRF4, KRS4, KRS5, KRS6, KRT, KRT4, KRT6		
13	90015-883-000	BOLT, FLANGE, 6X28	7	7	7	7			
14	90029-888-000	BOLT, FLANGE, 6X16(CT200) ...	1	-	-	-	AR, ARL, DKR, KR, KRA4, KRF4, KRS4, KRS5, KRS6, KRT, KRT4, KRT6		
15	91001-878-003	BEARING, RADIAL BALL, 62/22 -	1	1	1	1			



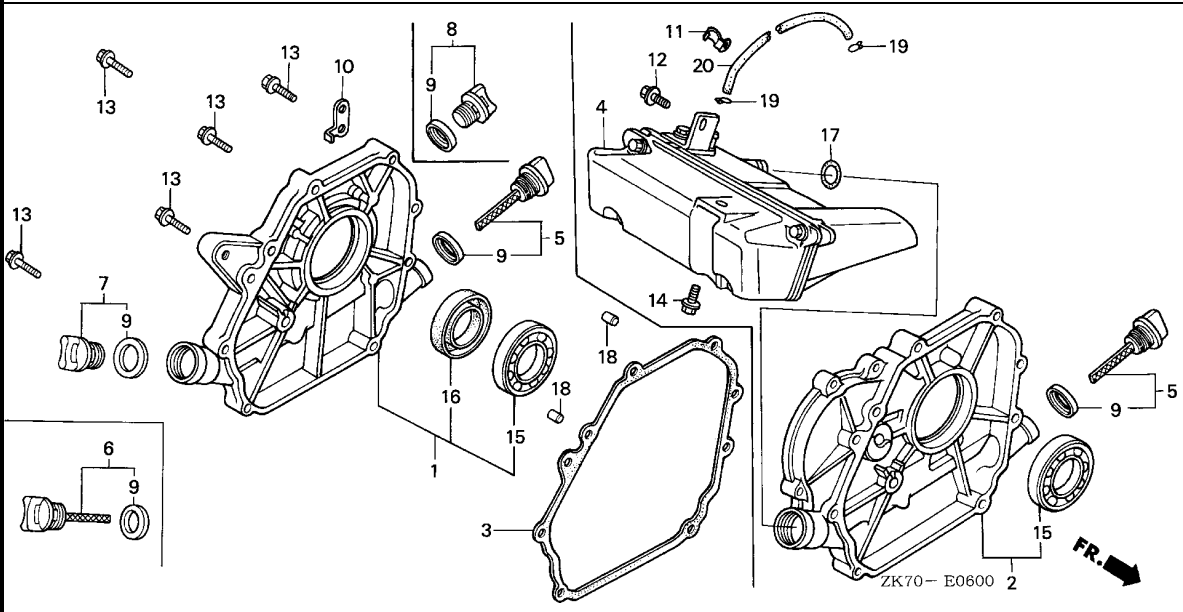

Ref. No.	Part No.	Description	Reqd. QTY				Serial No.	Parts catalogue code
			(1)	(2)	(3)	(4)		
16	91203-ZE0-013	OIL SEAL, 22X41X6	1	1	-	-	HHQ4,HTF2,HT2,HT24,HX,HXU,HX2,HX26,HX4,H1,PX,PX2,QA,QA2,QB26,QD,QH,QHQ4,QH26,QJG2,QLL,QM,QMA4,QMA8,QME4,QMX2,QT,QWA4,QX,QXC9,QXS2,QXU,QX2,QX26,QX4,QX7,Q1,RD,RD4,RHC,RHQ4,RX,RX4,R1,SAJ,SAJ4,SAR4,SCJ,SD,SD16,SD4,SE,SG24,SH,SHQ4,SJ,SJC1,SJC5,SJD2,SKR,SMA7,SMJ,SMW2,SM11,SM12,SM14,SSK1,SSK3,SSX2,SSX4,STP,STS,SWX2,SWX4,SX,SXS4,SX4,SX7,SYA,S1,TX,TX2,TX26,TX4,UXU,VED,VED1,VED6,VEE1,VEK,VET,VEX,VEX7,VMS4,VMT,VPM4,VPR4,VSX,VSX1,VX,VXU,VX4,VX7,WDA6,WD12,WJ,WJP,WKD6,WKT2,WKT4,WKT6,WMA3,WMA4,WME2,WME4,WMK,WM1,W1	
17	91304-MJO-003	O-RING, 15.8X2.4(SHOWA)	1	-	1	1	AR,ARL,DKR,KR,KRA4,KRF4,KRS4,KRS5,KRS6,KRT,KRT4,KRT6	
18	94301-08140	DOWEL PIN, 8X14	2	-	-	-	DS,HHQ4,HTF2,HT2,HT24,HX,HXU,HX2,HX26,HX4,KRT,KRT4,KRT6,LAJ,LAJ4,LD,LH,LHQ4,LJ,LJC,LJC8,LJD2,LJS,LSJ,LSJ4,LTJ,LTK1,LTR,LTS,LX,LXU,LX2,LX4,PX,PX2,QA,QA2,QB26,QD,QH,QHQ4,QH26,QJG2,QLL,QM,QMA4,QMA8,QME4,QMX2,QT,QWA4,QX,QXC9,QXS2,QXU,QX2,QX26,QX4,QX7,RD,RD4,RHC,RHQ4,RX,RX4,SAJ,SAJ4,SAR4,SCJ,SD,SD16,SD4,SE,SG24,SH,SHQ4,SJ,SJC1,SJC5,SJD2,SKR,SMA7,SMJ,SMW2,SM11,SM12,SM14,SSK1,SSK3,SSX2,SSX4,STP,STS,SWX2,SWX4,SX,SXS4,SX4,SX7,SYA,TX,TX2,TX26,TX4,UXU,VED,VED1,VED6,VEE1,VEK,VET,VEX,VEX7,VMS4,VMT,VPM4,VPR4,VSX,VSX1,VX,VXU,VX4,VX7,WDA6,WD12,WJ,WJP,WKD6,WKT2,WKT4,WKT6,WMA3,WMA4,WME2,WME4,WMK,WM1	
	94303-08140	-	2	2	2	AR,ARL,DKR,KR,KRA4,KRF4,KRS4,KRS5,KRS6	
	19 95002-02070	CLIP, TUBE (B7)	2	-	-	-	AR,ARL,DKR,KR,KRA4,KRF4,KRS4,KRS5,KRS6,KRT,KRT4,KRT6	
	20 95005-35150-10	TUBE, 3.5X150(95005-35001-10M)	1	-	-	-	AR,ARL,DKR,KR,KRA4,KRF4,KRS4,KRS5,KRS6,KRT,KRT4,KRT6	

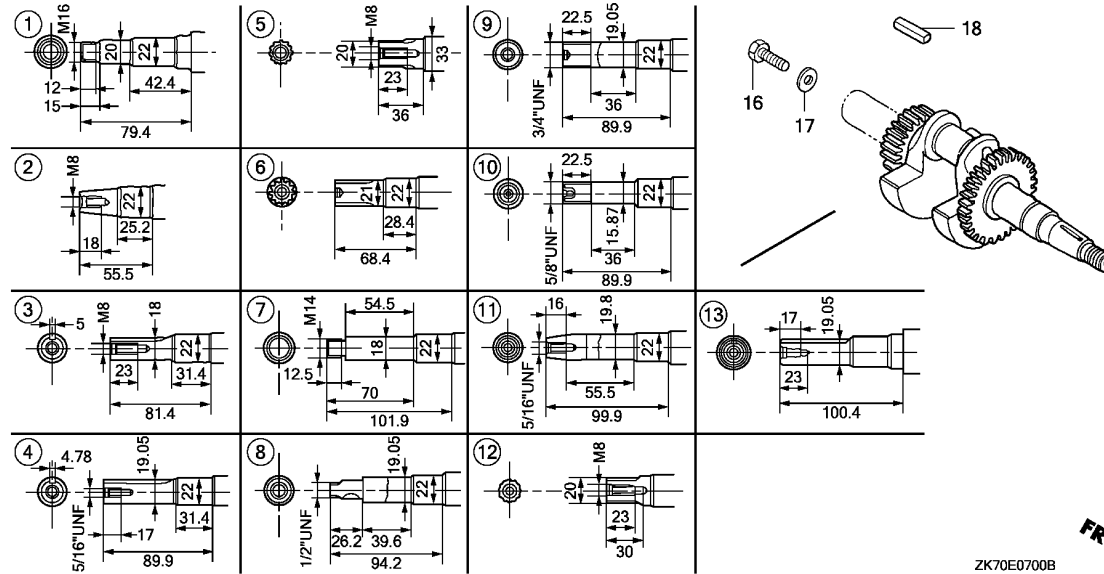

Ref. No.	L.O.N.	(Relative ref. Number) Description	F.R.T.
1	1101F0	(2,3,4,5,6,7,8,9,10,11,12,13) CRANKSHAFT	1.1

Ref. No.	Part No.	Description	Reqd. QTY				Serial No.	Parts catalogue code
			(1)	(2)	(3)	(4)		
1	13310-YB3-010	CRANKSHAFT COMP.	1	-	1	-	WIS, WJP, WME2, WME4	
2	13310-ZB0-000	CRANKSHAFT COMP.	1	-	-	-	VED, VED1, VED6, VEE1, VEK, VET, VMT	
3	13310-ZE0-000	CRANKSHAFT COMP.	1	1	1	-	RD, RD4, RHC, RHQ4, RX, RX4, R1, SAJ, SAJ4, SAR4, SCJ, SD, SD16, SD4, SE, SG24, SH, SHQ4, SIH, SJ, SJC1, SJC5, SJD2, SKR, SMA7, SMJ, SMW2, SM11, SM12, SM14, SSK1, SSK3, SSX2, SSX4, STP, STS, SWX2, SWX4, SX, SXS4, SX4, SYA, S1	
4	13310-ZK7-880	CRANKSHAFT COMP.	1	-	-	-	SX7	
4	13310-ZE0-601	CRANKSHAFT COMP.	1	1	-	1	QA, QA2, QB26, QD, QDBR, QH, QHQ4, QH26, QJG2, QLL, QM, QMA4, QMA8, QME4, QMX2, QT, QWA4, QX, QXBR, QXC9, QXS2, QXU, QX2, QX26, QX4, Q1	
5	13310-ZE0-610	CRANKSHAFT COMP.	1	1	-	-	DS, KRT, KRT4, KRT6, LAJ, LAJ4, LD, LH, LHQ4, LJ, LJC, LJC8, LJD2, LJS, LSJ, LSJ4, LTJ, LTK1, LTR, LTS, LX, LXU, LX2, LX4, L1	
6	13310-ZE0-622	CRANKSHAFT COMP.	1	1	-	-	HHQ4, HTF2, HT2, HT24, HX, HXU, HX2, HX26, HX4, H1	
7	13310-ZE0-631	CRANKSHAFT COMP.	1	1	1	-	WDA6, WD12, WIH, WJ, WKD6, WKT2, WKT4, WKT6, WMA3, WMA4, WMK, WM1, W1	
8	13310-ZE0-641	CRANKSHAFT COMP.	1	-	-	-	UXU	
9	13310-ZE0-650	CRANKSHAFT COMP.	1	-	-	-	PX, PX2	
10	13310-ZE0-660	CRANKSHAFT COMP.	1	-	-	1	TX, TXBR, TX2, TX26, TX4	
11	13310-ZE0-670	CRANKSHAFT COMP.	1	-	-	1	VEX, VMS4, VPM4, VPR4, VSX, VSX1, VX, VXBR, VXU, VX4	
	13310-ZK7-670	CRANKSHAFT COMP.	1	-	-	-	VEX7, VX7	
12	13310-ZK7-V00	CRANKSHAFT COMP.	1	-	-	-	AR, ARL, DKR, KR, KRA4, KRF4, KRS4, KRS5, KRS6	
13	13310-ZK7-600	CRANKSHAFT COMP.	1	-	-	-	QX7	
16	90003-ZE1-000	BOLT, HEX., 5/16"	-	(1)	-	-	Q1	
	92000-08025-0A	BOLT, HEX., 8X25	-	-	1	-	SIH	
	92101-08025-0A	BOLT, HEX., 8X25	1	(1)	-	-	LAJ, LAJ4, LJ, LJC, LJC8, LJS, LSJ, LSJ4, LTJ, LTK1, LTR, LTS, L1, RHC, R1, SAJ, SAJ4, SAR4, SCJ, SJ, SJC1, SJC5, SKR, SMJ, SMW2, SM11, SM12, SM14, SSK1, SSK3, SSX2, SSX4, STP, STS, S1	
17	90473-842-000	WASHER, 8MM	1	(1)	1	-	LAJ, LAJ4, LJ, LJC, LJC8, LJS, LSJ, LSJ4, LTJ, LTK1, LTR, LTS, L1, QT, Q1, RHC, R1, SAJ, SAJ4, SAR4, SCJ, SIH, SJ, SJC1, SJC5, SKR, SMJ, SMW2, SM11, SM12, SM14, SSK1, SSK3, SSX2, SSX4, STP, STS, S1	



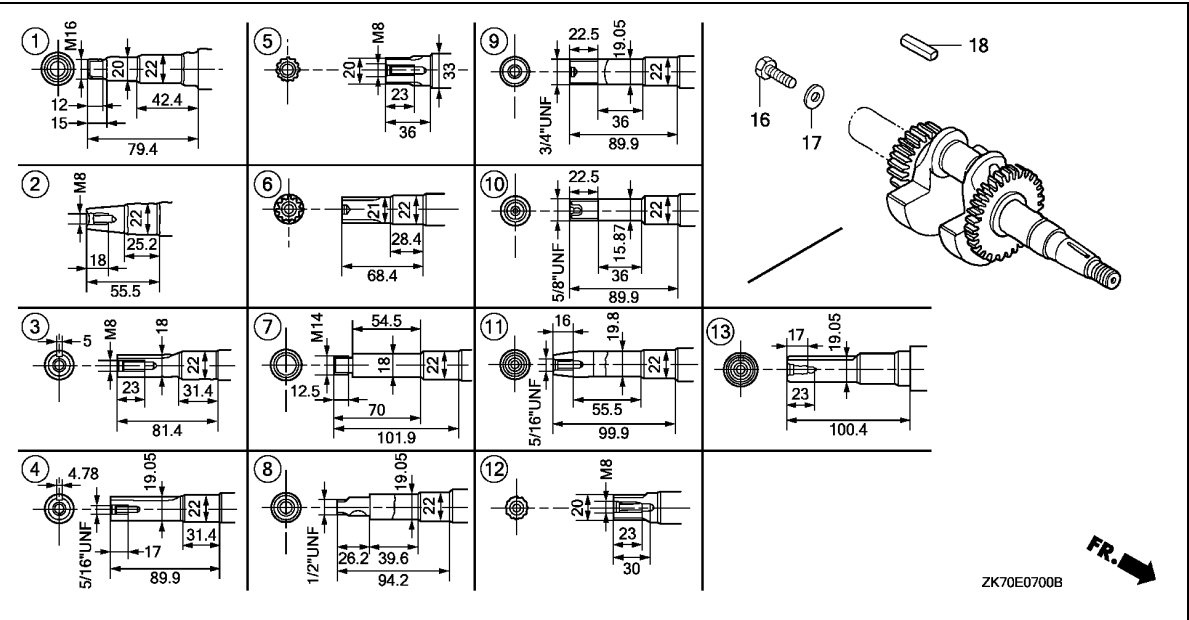

Ref. No.	Part No.	Description	Reqd. QTY				Serial No.	Parts catalogue code
			(1)	(2)	(3)	(4)		
18	90741-883-810	KEY, 5X5X33 (YELLOW)	1	(1)	1	-	KRT6, RD, RD4, SAJ, SAJ4, SAR4, SCJ, SD, SD16, SD4, SE, SG24, SH, SHQ4, SIH, SJ, SJC1, SJC5, SJD2, SKR, SMA7, SMJ, SMW2, SM11, SM12, SM14, SSK1, SSK3, SSSX2, SSSX4, STP, STS, SWX2, SWX4, SX, SXS4, SX4, SX7, S1	
	90745-ZE1-600	KEY, 4.78X4.78X38	1	(1)	-	1	QA, QA2, QD, QDBR, QJG2, QLL, QM, QMA4, QMA8, QT, QWA4, QX, QXBR, QXC9, QXS2, QXU, QX2, QX26, QX4, QX7, Q1	

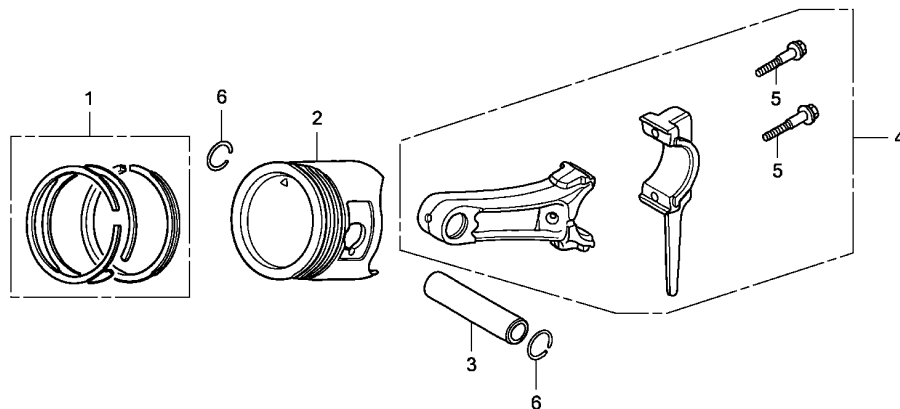

ZK70E0800A



Ref. No.	L.O.N.	(Relative ref. Number) Description	F.R.T.
2		(1,3,4)	
1111R1		PISTON AND/OR RING SET AND/OR BEARING AND/OR ROD INCLUDES: Inspection/ Measurement/Cleaning	1.1

Ref. No.	Part No.	Description	Reqd. QTY				Serial No.	Parts catalogue code
			(1)	GX120K1 (2)	(3)	(4)		
1	13010-ZH7-003	RING SET, PISTON (STD.) (TEIKOKU)	1	-	-	-	-----	AR,DKR,HHQ4,HTF2,HT2,HT24,HXU,HX2,HX26,HX4,KRA4,KRF4,KRS4,KRS5 KRS6,KRT4,LAJ4,LHQ4,LJD2,LSJ,LSJ4,LXU,LX2,LX4,PX2,QA2,QHQ4 QH26,QJG2,QLL,QM,QMA4,QMA8,QME4,QMX2,QT,QWA4,QXC9,QXS2,QXU,QX2 QX26,QX4,QX7,RD4,RHC,RHQ4,RX4,SAJ4,SAR4,SD16,SD4,SE,SG24,SHQ4 SJD2,SMA7,SMW2,SM12,SM14,SSX2,SSX4,SWX2,SWX4,SXS4,SX4,SX7,TX2 TX26,TX4,UXU,VED6,VEE1,VET,VEX,VEX7,VMS4,VPM4,VPR4,VXU,VX4,VX7 WDA6,WD12,WJP,WKD6,WKT2,WKT4,WKT6,WMA3,WME2,WME4
			1	-	-	-	4554249	ARL,DS,HX,KR,KRT,KRT6,LAJ,LD,LH,LJ,LJC,LJC8,LJS,LTJ,LTJ1,LTR LTS,LX,PX,QA,QB26,QD,QH,QX,RD,RX,SAJ,SCJ,SD,SH,SJ,SJC1,SJC5 SKR,SMJ,SM11,SSK1,SSK3,STP,STS,SX,SYA,TX,VED,VED1,VEK,VMT,VSX VSX1,VX,WJ,WMA4,WMK,WM1
			-	1	-	-	4554249	
			-	-	1	1		
	13010-ZH7-004	RING SET, PISTON (STD.) (NIPPON)	1	-	-	-	-----	AR,DKR,HHQ4,HTF2,HT2,HT24,HXU,HX2,HX26,HX4,KRA4,KRF4,KRS4,KRS5 KRS6,KRT4,LAJ4,LHQ4,LJD2,LSJ,LSJ4,LXU,LX2,LX4,PX2,QA2,QHQ4 QH26,QJG2,QLL,QM,QMA4,QMA8,QME4,QMX2,QT,QWA4,QXC9,QXS2,QXU,QX2 QX26,QX4,QX7,RD4,RHC,RHQ4,RX4,SAJ4,SAR4,SD16,SD4,SE,SG24,SHQ4 SJD2,SMA7,SMW2,SM12,SM14,SSX2,SSX4,SWX2,SWX4,SXS4,SX4,SX7,TX2 TX26,TX4,UXU,VED6,VEE1,VET,VEX,VEX7,VMS4,VPM4,VPR4,VXU,VX4,VX7 WDA6,WD12,WJP,WKD6,WKT2,WKT4,WKT6,WMA3,WME2,WME4
			1	-	-	-	4554249	ARL,DS,HX,KR,KRT,KRT6,LAJ,LD,LH,LJ,LJC,LJC8,LJS,LTJ,LTJ1,LTR LTS,LX,PX,QA,QB26,QD,QH,QX,RD,RX,SAJ,SCJ,SD,SH,SJ,SJC1,SJC5 SKR,SMJ,SM11,SSK1,SSK3,STP,STS,SX,SYA,TX,VED,VED1,VEK,VMT,VSX VSX1,VX,WJ,WMA4,WMK,WM1
			-	1	-	-	4554249	
			-	-	1	1		



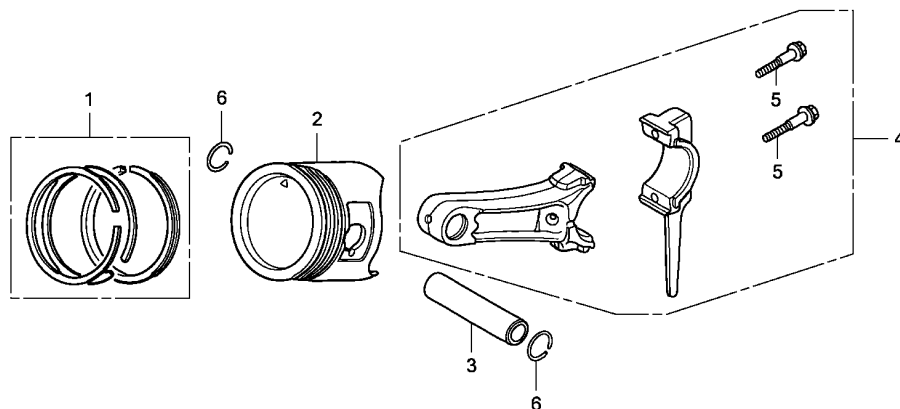

ZK70E0800A



2

Ref. No.	Part No.	Description	Reqd. QTY				Serial No.	Parts catalogue code
			(1)	(2)	(3)	(4)		
(1)	13011-ZH7-003	RING SET, PISTON (0.25) (TEIKOKU)	(1)	-	-	-	-	AR,DKR,HHQ4,HTF2,HT2,HT24,HXU,HX2,HX26,HX4,KRA4,KRF4,KRS4,KRS5 KRS6,KRT4,LAJ4,LHQ4,LJD2,LSJ,LSJ4,LXU,LX2,LX4,PX2,QA2,QHQ4 QH26,QJG2,QLL,QMA4,QMA8,QME4,QMX2,QWA4,QXC9,QXS2,QXU,QX2,QX26 QX4,QX7,RD4,RHC,RHQ4,RX4,SAJ4,SAR4,SD16,SD4,SE,SG24,SHQ4,SJD2 SMA7,SMW2,SM12,SM14,SSX2,SSX4,SWX2,SWX4,SXS4,SX4,SX7,TX2,TX26 TX4,UXU,VED6,VEE1,VET,VEX,VEX7,VMS4,VPM4,VPR4,VXU,VX4,VX7,WDA6 WD12,WJP,WKD6,WKT2,WKT4,WKT6,WMA3,WME2,WME4
			(1)	-	-	-	4554249	ARL,DS,HX,KR,KRT,KRT6,LAJ,LD,LH,LJ,LJC,LJC8,LJS,LTJ,LTJ1,LTR LTS,LX,PX,QA,QB26,QD,QH,QX,RD,RX,SAJ,SCJ,SD,SH,SJ,SJC1,SJC5 SKR,SMJ,SM11,SSK1,SSK3,STP,STS,SX,SYA,TX,VED,VED1,VEK,VMT,VSX VSX1,VX,WJ,WMA4,WMK,WM1
			-	(1)	-	-	4554249	
			-	-	-	(1)		
	13011-ZH7-004	RING SET, PISTON (0.25) (NIPPON)	(1)	-	-	-	-	AR,DKR,HHQ4,HTF2,HT2,HT24,HXU,HX2,HX26,HX4,KRA4,KRF4,KRS4,KRS5 KRS6,KRT4,LAJ4,LHQ4,LJD2,LSJ,LSJ4,LXU,LX2,LX4,PX2,QA2,QHQ4 QH26,QJG2,QLL,QMA4,QMA8,QME4,QMX2,QWA4,QXC9,QXS2,QXU,QX2,QX26 QX4,QX7,RD4,RHC,RHQ4,RX4,SAJ4,SAR4,SD16,SD4,SE,SG24,SHQ4,SJD2 SMA7,SMW2,SM12,SM14,SSX2,SSX4,SWX2,SWX4,SXS4,SX4,SX7,TX2,TX26 TX4,UXU,VED6,VEE1,VET,VEX,VEX7,VMS4,VPM4,VPR4,VXU,VX4,VX7,WDA6 WD12,WJP,WKD6,WKT2,WKT4,WKT6,WMA3,WME2,WME4
			(1)	-	-	-	4554249	ARL,DS,HX,KR,KRT,KRT6,LAJ,LD,LH,LJ,LJC,LJC8,LJS,LTJ,LTJ1,LTR LTS,LX,PX,QA,QB26,QD,QH,QX,RD,RX,SAJ,SCJ,SD,SH,SJ,SJC1,SJC5 SKR,SMJ,SM11,SSK1,SSK3,STP,STS,SX,SYA,TX,VED,VED1,VEK,VMT,VSX VSX1,VX,WJ,WMA4,WMK,WM1
			-	(1)	-	-	4554249	
			-	-	-	(1)		

Ref. No.	Part No.	Description	Reqd. QTY				Serial No.	Parts catalogue code
			(1)	(2)	(3)	(4)		
(1)	13012-ZH7-003	RING SET, PISTON (0.50) (TEIKOKU)	(1)	-	-	-	-----	AR,DKR,HHQ4,HTF2,HT2,HT24,HXU,HX2,HX26,HX4,KRA4,KRF4,KRS4,KRS5 KRS6,KRT4,LAJ4,LHQ4,LJD2,LSJ,LSJ4,LXU,LX2,LX4,PX2,QA2,QHQ4 QH26,QJG2,QLL,QMA4,QMA8,QME4,QMX2,QWA4,QXC9,QXS2,QXU,QX2,QX26 QX4,QX7,RD4,RHC,RHQ4,RX4,SAJ4,SAR4,SD16,SD4,SE,SG24,SHQ4,SJD2 SMA7,SMW2,SM12,SM14,SSX2,SSX4,SWX2,SWX4,SXS4, SX4, SX7, TX2, TX26 TX4,UXU,VED6,VEE1,VET,VEX,VEX7,VMS4,VPM4,VPR4,VXU,VX4,VX7,WDA6 WD12,WJP,WKD6,WKT2,WKT4,WKT6,WMA3,WME2,WME4
			(1)	-	-	-	-----	4554249 ARL,DS,HX,KR,KRT,KRT6,LAJ,LD,LH,LJ,LJC,LJC8,LJS,LTJ, LTK1,LTR LTS,LX,PX,QA,QB26,QD,QH,QX,RD,RX,SAJ,SCJ,SD,SH,SJ,SJC1,SJC5 SKR,SMJ,SM11,SSK1,SSK3,STP,STS,SX,SYA,TX,VED,VED1,VEK,VMT,VSX VSX1,VX,WJ,WMA4,WMK,WM1
			-	(1)	-	-	-----	4554249
			-	-	-	(1)		
	13012-ZH7-004	RING SET, PISTON (0.50) (NIPPON)	(1)	-	-	-	-----	AR,DKR,HHQ4,HTF2,HT2,HT24,HXU,HX2,HX26,HX4,KRA4,KRF4,KRS4,KRS5 KRS6,KRT4,LAJ4,LHQ4,LJD2,LSJ,LSJ4,LXU,LX2,LX4,PX2,QA2,QHQ4 QH26,QJG2,QLL,QMA4,QMA8,QME4,QMX2,QWA4,QXC9,QXS2,QXU,QX2,QX26 QX4,QX7,RD4,RHC,RHQ4,RX4,SAJ4,SAR4,SD16,SD4,SE,SG24,SHQ4,SJD2 SMA7,SMW2,SM12,SM14,SSX2,SSX4,SWX2,SWX4,SXS4, SX4, SX7, TX2, TX26 TX4,UXU,VED6,VEE1,VET,VEX,VEX7,VMS4,VPM4,VPR4,VXU,VX4,VX7,WDA6 WD12,WJP,WKD6,WKT2,WKT4,WKT6,WMA3,WME2,WME4
			(1)	-	-	-	-----	4554249 ARL,DS,HX,KR,KRT,KRT6,LAJ,LD,LH,LJ,LJC,LJC8,LJS,LTJ, LTK1,LTR LTS,LX,PX,QA,QB26,QD,QH,QX,RD,RX,SAJ,SCJ,SD,SH,SJ,SJC1,SJC5 SKR,SMJ,SM11,SSK1,SSK3,STP,STS,SX,SYA,TX,VED,VED1,VEK,VMT,VSX VSX1,VX,WJ,WMA4,WMK,WM1
			-	(1)	-	-	-----	4554249
			-	-	-	(1)		
	13013-ZH7-003	RING SET, PISTON (0.75) (TEIKOKU)	(1)	-	-	-	-----	AR,DKR,HHQ4,HTF2,HT2,HT24,HXU,HX2,HX26,HX4,KRA4,KRF4,KRS4,KRS5 KRS6,KRT4,LAJ4,LHQ4,LJD2,LSJ,LSJ4,LXU,LX2,LX4,PX2,QA2,QHQ4 QH26,QJG2,QLL,QMA4,QMA8,QME4,QMX2,QWA4,QXC9,QXS2,QXU,QX2,QX26 QX4,QX7,RD4,RHC,RHQ4,RX4,SAJ4,SAR4,SD16,SD4,SE,SG24,SHQ4,SJD2 SMA7,SMW2,SM12,SM14,SSX2,SSX4,SWX2,SWX4,SXS4, SX4, SX7, TX2, TX26 TX4,UXU,VED6,VEE1,VET,VEX,VEX7,VMS4,VPM4,VPR4,VXU,VX4,VX7,WDA6 WD12,WJP,WKD6,WKT2,WKT4,WKT6,WMA3,WME2,WME4
			(1)	-	-	-	-----	4554249 ARL,DS,HX,KR,KRT,KRT6,LAJ,LD,LH,LJ,LJC,LJC8,LJS,LTJ, LTK1,LTR LTS,LX,PX,QA,QB26,QD,QH,QX,RD,RX,SAJ,SCJ,SD,SH,SJ,SJC1,SJC5 SKR,SMJ,SM11,SSK1,SSK3,STP,STS,SX,SYA,TX,VED,VED1,VEK,VMT,VSX VSX1,VX,WJ,WMA4,WMK,WM1
			-	(1)	-	-	-----	4554249
			-	-	-	(1)		
	13013-ZH7-004	RING SET, PISTON (0.75) (NIPPON)	(1)	-	-	-	-----	AR,DKR,HHQ4,HTF2,HT2,HT24,HXU,HX2,HX26,HX4,KRA4,KRF4,KRS4,KRS5 KRS6,KRT4,LAJ4,LHQ4,LJD2,LSJ,LSJ4,LXU,LX2,LX4,PX2,QA2,QHQ4 QH26,QJG2,QLL,QMA4,QMA8,QME4,QMX2,QWA4,QXC9,QXS2,QXU,QX2,QX26 QX4,QX7,RD4,RHC,RHQ4,RX4,SAJ4,SAR4,SD16,SD4,SE,SG24,SHQ4,SJD2 SMA7,SMW2,SM12,SM14,SSX2,SSX4,SWX2,SWX4,SXS4, SX4, SX7, TX2, TX26 TX4,UXU,VED6,VEE1,VET,VEX,VEX7,VMS4,VPM4,VPR4,VXU,VX4,VX7,WDA6 WD12,WJP,WKD6,WKT2,WKT4,WKT6,WMA3,WME2,WME4
			(1)	-	-	-	-----	4554249 ARL,DS,HX,KR,KRT,KRT6,LAJ,LD,LH,LJ,LJC,LJC8,LJS,LTJ, LTK1,LTR LTS,LX,PX,QA,QB26,QD,QH,QX,RD,RX,SAJ,SCJ,SD,SH,SJ,SJC1,SJC5 SKR,SMJ,SM11,SSK1,SSK3,STP,STS,SX,SYA,TX,VED,VED1,VEK,VMT,VSX VSX1,VX,WJ,WMA4,WMK,WM1
			-	(1)	-	-	-----	4554249
			-	-	-	(1)		

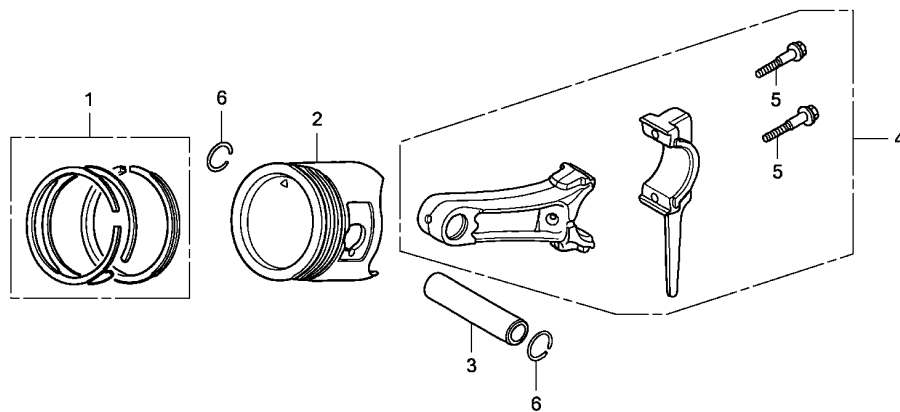

ZK70E0800A



Ref. No.	Part No.	Description	Reqd. QTY				Serial No.	Parts catalogue code
			(1)	GX120K1 (2)	(3)	(4)		
(1)	13010-Z4F-004	RING SET, PISTON (STD.) (TEIKOKU)	1	-	-	-	4554250	----- ARL,DS,HX,KR,KRT,KRT6,LAJ,LD,LH,LJ,LJC,LJC8,LJS,LTJ,LTK1,LTR LTS,LX,PX,QA,QB26,QD,QH,QX,RD,RX,SAJ,SCJ,SD,SH,SJ,SJC1,SJC5 SKR,SMJ,SM11,SSK1,SSK3,STP,STS,SX,SYA,TX,VED,VED1,VEK,VMT,VSX VSX1,VX,WJ,WMA4,WMK,WM1
	13011-Z4F-004	RING SET, PISTON (0.25) (TEIKOKU)	(1)	-	-	-	4554250	----- ARL,DS,HX,KR,KRT,KRT6,LAJ,LD,LH,LJ,LJC,LJC8,LJS,LTJ,LTK1,LTR LTS,LX,PX,QA,QB26,QD,QH,QX,RD,RX,SAJ,SCJ,SD,SH,SJ,SJC1,SJC5 SKR,SMJ,SM11,SSK1,SSK3,STP,STS,SX,SYA,TX,VED,VED1,VEK,VMT,VSX VSX1,VX,WJ,WMA4,WMK,WM1
	13012-Z4F-004	RING SET, PISTON (0.50) (TEIKOKU)	(1)	-	-	-	4554250	----- ARL,DS,HX,KR,KRT,KRT6,LAJ,LD,LH,LJ,LJC,LJC8,LJS,LTJ,LTK1,LTR LTS,LX,PX,QA,QB26,QD,QH,QX,RD,RX,SAJ,SCJ,SD,SH,SJ,SJC1,SJC5 SKR,SMJ,SM11,SSK1,SSK3,STP,STS,SX,SYA,TX,VED,VED1,VEK,VMT,VSX VSX1,VX,WJ,WMA4,WMK,WM1
	13013-Z4F-004	RING SET, PISTON (0.75) (TEIKOKU)	(1)	-	-	-	4554250	----- ARL,DS,HX,KR,KRT,KRT6,LAJ,LD,LH,LJ,LJC,LJC8,LJS,LTJ,LTK1,LTR LTS,LX,PX,QA,QB26,QD,QH,QX,RD,RX,SAJ,SCJ,SD,SH,SJ,SJC1,SJC5 SKR,SMJ,SM11,SSK1,SSK3,STP,STS,SX,SYA,TX,VED,VED1,VEK,VMT,VSX VSX1,VX,WJ,WMA4,WMK,WM1
2	13101-ZF0-020	PISTON (STD.)	1	-	-	-	-----	QM,QT
	13101-ZF0-902	-	-	1	-		

Ref. No.	Part No.	Description	Reqd. QTY				Serial No.	Parts catalogue code
			(1)	GX120K1 (2)	(3)	(4)		
(2)	13101-ZH7-010	PISTON (STD.)	1	-	-	-	AR,DKR,HHQ4,HTF2,HT2,HT24,HXU,HX2,HX26,HX4,KRA4,KRF4,KRS4,KRS5 KRS6,KRT4,LAJ4,LHQ4,LJD2,LSJ,LSJ4,LXU,LX2,LX4,PX2,QA2,QHQ4 QH26,QJG2,QLL,QMA4,QMA8,QME4,QMX2,QWA4,QXC9,QXS2,QXU,QX2,QX26 QX4,QX7,RD4,RHC,RHQ4,RX4,SAJ4,SAR4,SD16,SD4,SE,SG24,SHQ4,SJD2 SMA7,SMW2,SM12,SM14,SSX2,SSX4,SWX2,SWX4,SXS4, SX4, SX7, TX2, TX26 TX4,UXU,VED6,VEE1,VET,VEX,VEX7,VMS4,VPM4,VPR4,VXU,VX4,VX7,WDA6 WD12,WJP,WKD6,WKT2,WKT4,WKT6,WMA3,WME2,WME4	
			1	-	-	-	4554249 ARL,DS,HX,KR,KRT,KRT6,LAJ,LD,LH,LJ,LJC,LJC8,LJS,LTJ, LTK1,LTR LTS,LX,PX,QA,QB26,QD,QH,QX,RD,RX,SAJ,SCJ,SD,SH,SJ,SJC1,SJC5 SKR,SMJ,SM11,SSK1,SSK3,STP,STS,SX,SYA,TX,VED,VED1,VEK,VMT,VSX VSX1,VX,WJ,WMA4,WMK,WM1	
			-	1	-	-	4554249	
			-	-	-	1		
	13102-ZH7-010	PISTON (0.25)	(1)	-	-	-	AR,DKR,HHQ4,HTF2,HT2,HT24,HXU,HX2,HX26,HX4,KRA4,KRF4,KRS4,KRS5 KRS6,KRT4,LAJ4,LHQ4,LJD2,LSJ,LSJ4,LXU,LX2,LX4,PX2,QA2,QHQ4 QH26,QJG2,QLL,QMA4,QMA8,QME4,QMX2,QWA4,QXC9,QXS2,QXU,QX2,QX26 QX4,QX7,RD4,RHC,RHQ4,RX4,SAJ4,SAR4,SD16,SD4,SE,SG24,SHQ4,SJD2 SMA7,SMW2,SM12,SM14,SSX2,SSX4,SWX2,SWX4,SXS4, SX4, SX7, TX2, TX26 TX4,UXU,VED6,VEE1,VET,VEX,VEX7,VMS4,VPM4,VPR4,VXU,VX4,VX7,WDA6 WD12,WJP,WKD6,WKT2,WKT4,WKT6,WMA3,WME2,WME4	
			(1)	-	-	-	4554249 ARL,DS,HX,KR,KRT,KRT6,LAJ,LD,LH,LJ,LJC,LJC8,LJS,LTJ, LTK1,LTR LTS,LX,PX,QA,QB26,QD,QH,QX,RD,RX,SAJ,SCJ,SD,SH,SJ,SJC1,SJC5 SKR,SMJ,SM11,SSK1,SSK3,STP,STS,SX,SYA,TX,VED,VED1,VEK,VMT,VSX VSX1,VX,WJ,WMA4,WMK,WM1	
			-	(1)	-	-	4554249	
			-	-	-	(1)		
	13103-ZH7-010	PISTON (0.50)	(1)	-	-	-	AR,DKR,HHQ4,HTF2,HT2,HT24,HXU,HX2,HX26,HX4,KRA4,KRF4,KRS4,KRS5 KRS6,KRT4,LAJ4,LHQ4,LJD2,LSJ,LSJ4,LXU,LX2,LX4,PX2,QA2,QHQ4 QH26,QJG2,QLL,QMA4,QMA8,QME4,QMX2,QWA4,QXC9,QXS2,QXU,QX2,QX26 QX4,QX7,RD4,RHC,RHQ4,RX4,SAJ4,SAR4,SD16,SD4,SE,SG24,SHQ4,SJD2 SMA7,SMW2,SM12,SM14,SSX2,SSX4,SWX2,SWX4,SXS4, SX4, SX7, TX2, TX26 TX4,UXU,VED6,VEE1,VET,VEX,VEX7,VMS4,VPM4,VPR4,VXU,VX4,VX7,WDA6 WD12,WJP,WKD6,WKT2,WKT4,WKT6,WMA3,WME2,WME4	
			(1)	-	-	-	4554249 ARL,DS,HX,KR,KRT,KRT6,LAJ,LD,LH,LJ,LJC,LJC8,LJS,LTJ, LTK1,LTR LTS,LX,PX,QA,QB26,QD,QH,QX,RD,RX,SAJ,SCJ,SD,SH,SJ,SJC1,SJC5 SKR,SMJ,SM11,SSK1,SSK3,STP,STS,SX,SYA,TX,VED,VED1,VEK,VMT,VSX VSX1,VX,WJ,WMA4,WMK,WM1	
			-	(1)	-	-	4554249	
			-	-	-	(1)		
	13104-ZH7-010	PISTON (0.75)	(1)	-	-	-	AR,DKR,HHQ4,HTF2,HT2,HT24,HXU,HX2,HX26,HX4,KRA4,KRF4,KRS4,KRS5 KRS6,KRT4,LAJ4,LHQ4,LJD2,LSJ,LSJ4,LXU,LX2,LX4,PX2,QA2,QHQ4 QH26,QJG2,QLL,QMA4,QMA8,QME4,QMX2,QWA4,QXC9,QXS2,QXU,QX2,QX26 QX4,QX7,RD4,RHC,RHQ4,RX4,SAJ4,SAR4,SD16,SD4,SE,SG24,SHQ4,SJD2 SMA7,SMW2,SM12,SM14,SSX2,SSX4,SWX2,SWX4,SXS4, SX4, SX7, TX2, TX26 TX4,UXU,VED6,VEE1,VET,VEX,VEX7,VMS4,VPM4,VPR4,VXU,VX4,VX7,WDA6 WD12,WJP,WKD6,WKT2,WKT4,WKT6,WMA3,WME2,WME4	
			(1)	-	-	-	4554249 ARL,DS,HX,KR,KRT,KRT6,LAJ,LD,LH,LJ,LJC,LJC8,LJS,LTJ, LTK1,LTR LTS,LX,PX,QA,QB26,QD,QH,QX,RD,RX,SAJ,SCJ,SD,SH,SJ,SJC1,SJC5 SKR,SMJ,SM11,SSK1,SSK3,STP,STS,SX,SYA,TX,VED,VED1,VEK,VMT,VSX VSX1,VX,WJ,WMA4,WMK,WM1	
			-	(1)	-	-	4554249	
			-	-	-	(1)		
	13101-ZH7-020	PISTON (STD.)	1	-	-	-	4554250 ARL,DS,HX,KR,KRT,KRT6,LAJ,LD,LH,LJ,LJC,LJC8,LJS,LTJ, LTK1,LTR LTS,LX,PX,QA,QB26,QD,QH,QX,RD,RX,SAJ,SCJ,SD,SH,SJ,SJC1,SJC5 SKR,SMJ,SM11,SSK1,SSK3,STP,STS,SX,SYA,TX,VED,VED1,VEK,VMT,VSX VSX1,VX,WJ,WMA4,WMK,WM1	
			-	1	-	-	4554250	



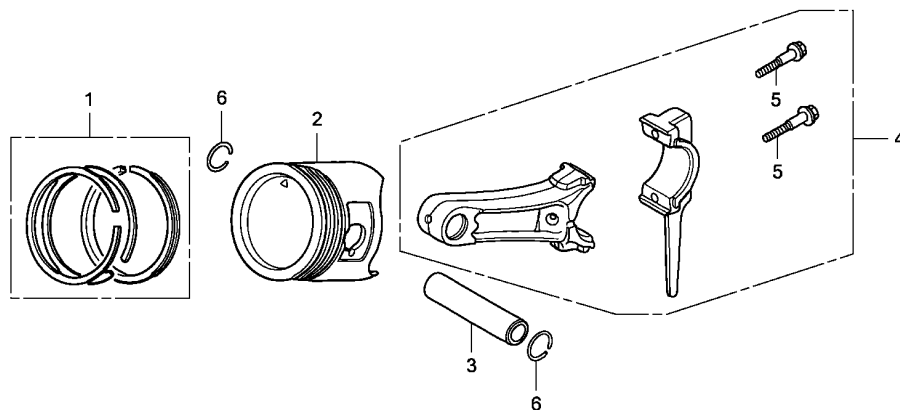

ZK70E0800A



Ref. No.	Part No.	Description	Reqd. QTY				Serial No.	Parts catalogue code
			(1)	GX120K1 (2)	(3)	(4)		
(2)	13102-ZH7-020	PISTON (0.25)	(1)	-	-	-	4554250	ARL,DS,HX,KR,KRT,KRT6,LAJ,LD,LH,LJ,LJC,LJC8,LJS,LTJ,LTK1,LTR LTS,LX,PX,QA,QB26,QD,QH,QX,RD,RX,SAJ,SCJ,SD,SH,SJ,SJC1,SJC5 SKR,SMJ,SM11,SSK1,SSK3,STP,STS,SX,SYA,TX,VED,VED1,VEK,VMT,VSX VSX1,VX,WJ,WMA4,WMK,WM1
	13103-ZH7-020	PISTON (0.50)	(1)	-	-	-	4554250	ARL,DS,HX,KR,KRT,KRT6,LAJ,LD,LH,LJ,LJC,LJC8,LJS,LTJ,LTK1,LTR LTS,LX,PX,QA,QB26,QD,QH,QX,RD,RX,SAJ,SCJ,SD,SH,SJ,SJC1,SJC5 SKR,SMJ,SM11,SSK1,SSK3,STP,STS,SX,SYA,TX,VED,VED1,VEK,VMT,VSX VSX1,VX,WJ,WMA4,WMK,WM1
	13104-ZH7-020	PISTON (0.75)	(1)	-	-	-	4554250	ARL,DS,HX,KR,KRT,KRT6,LAJ,LD,LH,LJ,LJC,LJC8,LJS,LTJ,LTK1,LTR LTS,LX,PX,QA,QB26,QD,QH,QX,RD,RX,SAJ,SCJ,SD,SH,SJ,SJC1,SJC5 SKR,SMJ,SM11,SSK1,SSK3,STP,STS,SX,SYA,TX,VED,VED1,VEK,VMT,VSX VSX1,VX,WJ,WMA4,WMK,WM1
3	13111-ZE0-000	PIN, PISTON	1	(1)	-	-	4554250	
4	13200-ZE0-000	ROD ASSY., CONNECTING	1	1	1	1		
	132A0-ZE0-000	ROD ASSY., CONNECTING (UNDER SIZE)	-	-	(1)	-		SIH,WIH
5	90001-ZE1-000	BOLT, CONNECTING ROD	2	2	2	2		
6	90551-ZE0-000	CLIP, PISTON PIN, 13MM	2	2	2	2		

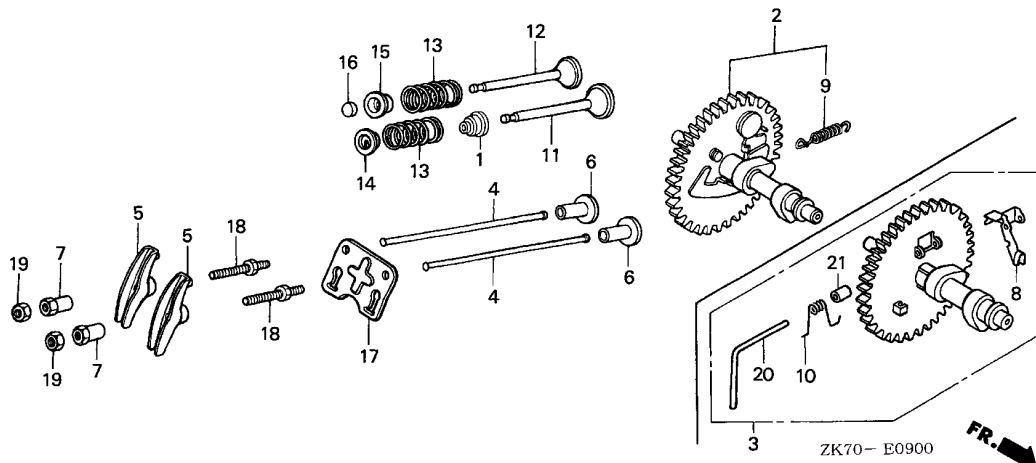

Ref. No.	L.O.N.	(Relative ref. Number) Description	F.R.T.
1	1111K2	SEAL, INTAKE VALVE STEMINCLUDES: Valve clearance adjustment	0.6
2	1111C2	CAMSHAFTINCLUDES: Valve clearance adjustment	0.4
4	1111L6	ROD, PUSH :INTAKEINCLUDES: Valve clearance adjustment	0.2
	1111L6A	.Replace exhaust push rod add	0.1
	1111L7	ROD, PUSH :EXHAUSTINCLUDES: Valve clearance adjustment	0.2
	1111L7A	.Replace intake push rod add	0.1
5	1111A2	ARM, ROCKER :INTAKEINCLUDES: Valve clearance adjustment	0.2
	1111A2C	.Replace intake and exhaust all add	0.1
	1111A1	ARM, ROCKER :EXHAUSTINCLUDES: Valve clearance adjustment	0.2
	1111A1C	.Replace intake and exhaust all add	0.1

Ref. No.	Part No.	Description	Reqd. QTY				Serial No.	Parts catalogue code
			(1)	GX120K1 (2)	(3)	(4)		
1	12209-ZH8-003	SEAL, VALVE STEM	1	1	1	1		
2	14100-ZE0-812	CAMSHAFT ASSY.	1	-	-	-	DS,HHQ4,HTF2,HT2,HT24,HX,HXU,HX2,HX26,HX4,LAJ,LAJ4,LD,LH,LHQ4,LJ,LJC,LJC8,LJD2,LJS,LSJ,LSJ4,LTJ,LTK1,LTR,LTS,LX,LXU,LX2,LX4,PX,PX2,QA,QA2,QB26,QD,QH,QHQ4,QH26,QJG2,QLL,QMA4,QMA8,QME4,QMX2,QWA4,QX,QXC9,QXS2,QXU,QX2,QX26,QX4,RD,RD4,RHC,RHQ4,RX,RX4,SAJ,SAJ4,SAR4,SCJ,SD,SD16,SD4,SE,SG24,SH,SHQ4,SJ,SJD2,SKR,SMA7,SMJ,SMW2,SM11,SM12,SM14,SSK1,SSK3,SSX2,SSX4,STP,STS,SWX2,SWX4,SX,SXS4,SX4,SYA,TX,TX2,TX26,TX4,UXU,VED,VED1,VED6,VEE1,VEK,VET,VEX,VMS4,VMT,VPM4,VPR4,VSX,VSX1,VX,VXU,VX4,WDA6,WD12,WJ,WJP,WKD6,WKT2,WKT4,WKT6,WMA3,WMA4,WME2,WME4,WMK	
	14100-ZF0-000	1	-	-	1	QM,QT,SJC1,SJC5	
	14100-ZH7-B20	1	-	-	-	AR,ARL,DKR,KR,KRA4,KRF4,KRS4,KRS5,KRS6,KRT,KRT4,KRT6	
	14100-ZK7-870	1	-	-	-	QX7,SX7,VEX7,VX7	
3	14100-ZK7-800	CAMSHAFT ASSY.	1	-	-	-	WM1	
4	14410-ZE0-010	ROD, PUSH	2	2	2	2		
5	14431-ZE1-000	ARM, VALVE ROCKER	2	2	2	2		
6	14441-ZE1-010	LIFTER, VALVE	2	2	2	2		
7	14451-ZE1-003	PIVOT, ROCKER ARM	-	-	2	-	SIH,WIH	
	14451-ZE1-013	2	2	-	2		
			-	-	2	-	WIS	
8	14560-ZK7-800	WEIGHT COMP., DECOMPER	1	-	-	-	WM1	



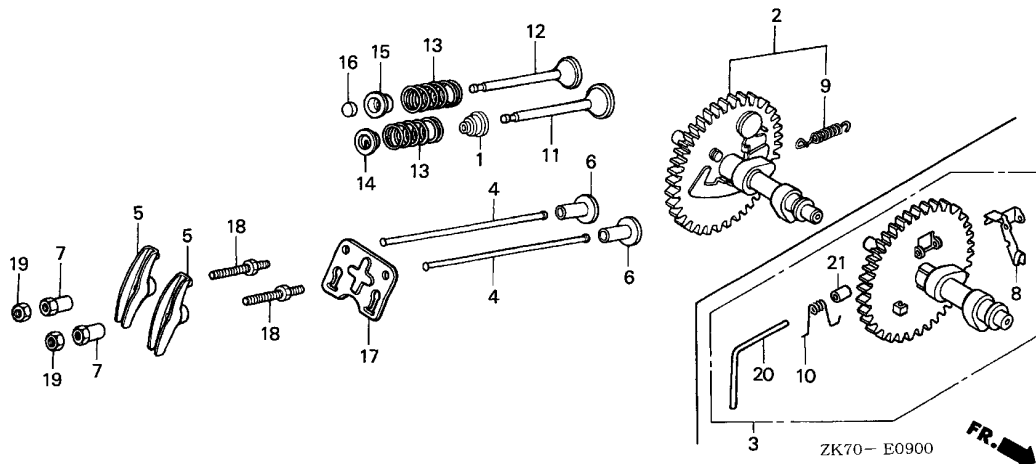

Ref. No.	L.O.N.	(Relative ref. Number) Description	F.R.T.
6	1111L9	LIFTER, VALVE :INTAKE	0.4
		.NOTE: Same time for two units	
	1111M0	LIFTER, VALVE :EXHAUST	0.4
		.NOTE: Same time for two units	
11	1111L1	VALVE, INTAKE	0.7
		.INCLUDES: Valve clearance adjustment and reface	
	1111LE	.Replace intake and exhaust all add	0.2
12	1111L0	VALVE, EXHAUST	0.7
		.INCLUDES: Valve clearance adjustment and reface	
	1111LE	.Replace intake and exhaust all add	0.2
13	1111P3	SPRING, VALVE :INTAKE	0.6
		.INCLUDES: Valve clearance adjustment	
	1111P3A	.Replace intake and exhaust all add	0.1
	1111P4	SPRING, VALVE :EXHAUST	0.6
		.INCLUDES: Valve clearance adjustment	
	1111P4A	.Replace intake and exhaust all add	0.1
+16	1111J7	ROTATOR, VALVE	0.2

Ref. No.	Part No.	Description	Reqd. QTY				Serial No.	Parts catalogue code
			(1)	GX120K1 (2)	(3)	(4)		
9	14568-ZE1-000	SPRING, WEIGHT RETURN	1	-	-	-	AR, ARL, DKR, DS, HHQ4, HTF2, HT2, HT24, HX, HXU, HX2, HX26, HX4, KR, KRA4, KRF4, KRS4, KRS5, KRS6, KRT, KRT4, KRT6, LAJ, LAJ4, LD, LH, LHQ4, LJ, LJC, LJC8, LJD2, LJS, LSJ, LSJ4, LTJ, LTK1, LTR, LTS, LX, LXU, LX2, LX4, PX, PX2, QA, QA2, QB26, QD, QH, QHQ4, QH26, QJG2, QLL, QM, QMA4, QMA8, QME4, QMX2, QT, QWA4, QX, QXC9, QXS2, QXU, QX2, QX26, QX4, QX7, RD, RD4, RHC, RHQ4, RX, RX4, SAJ, SAJ4, SAR4, SCJ, SD, SD16, SD4, SE, SG24, SH, SHQ4, SJ, SJC1, SJC5, SJD2, SKR, SMA7, SMJ, SMW2, SM11, SM12, SM14, SSK1, SSK3, SSS2, SSS4, STP, STS, SWX2, SWX4, SX, SXS4, SX4, SX7, SYA, TX, TX2, TX26, TX4, UXU, VED, VED1, VED6, VEE1, VEK, VET, VEX, VEX7, VMS4, VMT, VPM4, VPR4, VSX, VSX1, VX, VXU, VX4, VX7, WDA6, WD12, WJ, WJP, WKD6, WKT2, WKT4, WKT6, WMA3, WMA4, WME2, WME4, WMK	
10	14568-ZG9-800	SPRING, WEIGHT RETURN	1	-	-	-	WM1	
11	14711-ZF0-000 14711-ZF0-010	VALVE, IN.	-	-	1	1	QDBR, QXBR, SIH, WIH	
12	14721-ZF0-000	VALVE, EX.	1	-	-	1	TXBR, VXBR, WIS AR, ARL, DKR, DS, HHQ4, HTF2, HT2, HT24, HX, HXU, HX2, HX26, HX4, KR, KRA4, KRF4, KRS4, KRS5, KRS6, KRT, KRT4, KRT6, LAJ, LAJ4, LD, LH, LHQ4, LJ, LJC, LJC8, LJD2, LJS, LSJ, LSJ4, LTJ, LTK1, LTR, LTS, LX, LXU, LX2, LX4, QA, QA2, QB26, QD, QDBR, QH, QHQ4, QH26, QJG2, QLL, QM, QMA4, QMA8, QME4, QMX2, QT, QWA4, QX, QXBR, QXC9, QXS2, QXU, QX2, QX26, QX4, QX7, RD, RD4, RHC, RHQ4, RX, RX4, SAJ, SAJ4, SAR4, SCJ, SD, SD16, SD4, SE, SG24, SH, SHQ4, SJ, SJC1, SJC5, SJD2, SKR, SMA7, SMJ, SMW2, SM11, SM12, SM14, SSK1, SSK3, SSS2, SSS4, STP, STS, SWX2, SWX4, SX, SXS4, SX4, SX7, SYA, VED, VED1, VED6, VEE1, VEK, VET, VEX, VEX7, VMS4, VMT, VPM4, VPR4, VSX, VSX1, VX, VXBR, VXU, VX4, VX7, WDA6, WD12, WJ, WJP, WKD6, WKT2, WKT4, WKT6, WMA3, WMA4, WME2, WME4, WMK, WM1	
			-	(1)	1	-		

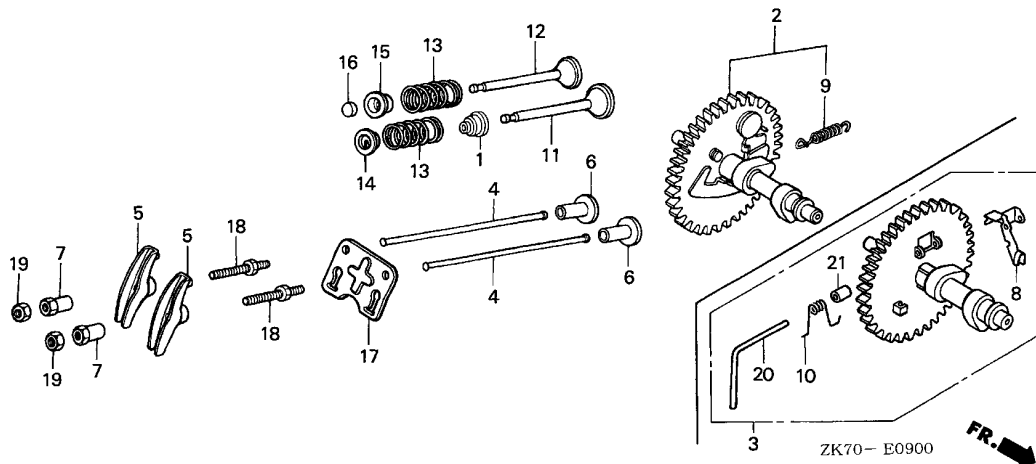

Ref. No.	L.O.N.	(Relative ref. Number) Description	F.R.T.
----------	--------	------------------------------------	--------

+16		.INCLUDES: Valve clearance adjustment	
-----	--	---------------------------------------	--

Ref. No.	Part No.	Description	Reqd. QTY				Serial No.	Parts catalogue code
			(1)	GX120K1 (2)	(3)	(4)		
12)	14721-ZH7-810	VALVE, EX. (STELLITE)	1	-	-	1	----- PX,PX2,TX,TXBR,TX2,TX26,TX4,UXU	
			-	(1)	-	-		
13	14751-ZF1-000	SPRING, VALVE	2	2	2	2		
14	14771-ZE1-000	RETAINER, IN. VALVE SPRING	1	1	1	1		
15	14773-ZE1-000	RETAINER, EX. VALVE SPRING	1	1	1	1		
16	14781-ZE1-000	ROTATOR, VALVE	1	1	1	1		
17	14791-ZE0-010	PLATE, PUSH ROD GUIDE	1	1	1	1		
18	90012-ZE0-010	BOLT, PIVOT, 8MM	2	2	2	2		
19	90206-ZE1-000	NUT, PIVOT ADJUSTING	2	2	2	2		
20	90701-ZG9-800	PIN, WEIGHT CENTER	1	-	-	-	----- WM1	
21	91502-ZG9-800	COLLAR, WEIGHT CENTER	1	-	-	-	----- WM1	



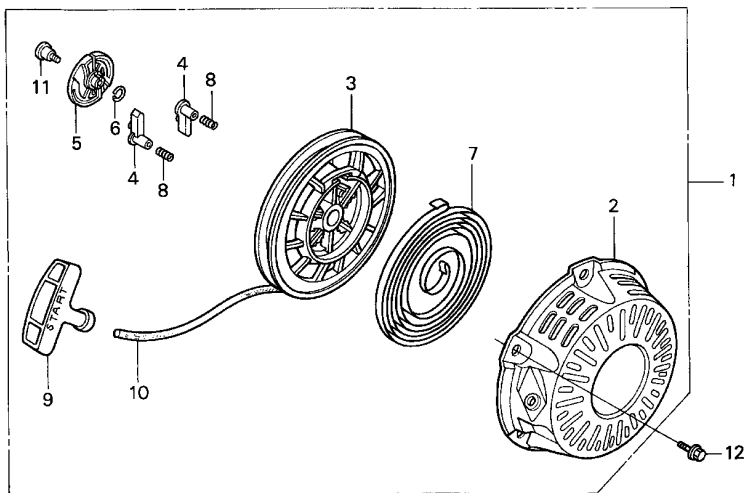

ZK70-E1100

Ref. No.	L.O.N.	(Relative ref. Number) Description	F.R.T.
1	1121B9	STARTER, RECOIL	0.1
3	1121B1	REEL, RECOIL STARTER	0.3
4	1121B0	RATCHET, STARTER AND/OR SPRING, RATCHET	0.2
		.NOTE: Same time for two units	
5	1121A4	GUIDE, RATCHET	0.2
7	1121B7	SPRING, RECOIL STARTER RETURN	0.3
10	1121B3	ROPE, RECOIL STARTER	0.3

Ref. No.	Part No.	Description	Reqd. QTY				Serial No.	Parts catalogue code
			(1)	GX120K1 (2)	(3)	(4)		
1	28400-ZH8-R10ZD	STARTER ASSY., RECOIL (TURFCO) *R280*.....POWER RED	1	-	-	-	4363433 LAJ, LAJ4	
	28400-ZH8-013ZB	STARTER ASSY., RECOIL *NH1*.....BLACK	1	-	-	-	4363433 AR, HX2, KR, PX2, QMX2, QWA4, QXC9, QXS2, QXU, QX2, SG24, SM11, SM12, SM14 SSK1, SSK3, SSX2, SSX4, TX4, VED, VED1, VED6, VEE1, VSX, VSX1	
	28400-ZH8-013ZG	*NH105*...MAT BLACK (#15-#20)	-	(1)	-	-	4363433	
	28400-ZH8-013ZJ	*T51*.....JACOBSEN ORANGE	1	-	-	-	4363433 SWX2, SWX4	
	28400-ZH8-013ZK	*NH31*.....MCKINLEY WHITE	1	-	-	-	4363433 LJD2, QJG2, SJD2	
	28400-ZH8-013ZV	*T79*.....BOMBARDIER YELLOW	1	-	-	-	4363433 QJG2	
	28400-ZH8-013ZW	*T80*.....BAKELITE ORANGE	1	-	-	-	4363433 VEK	
	28400-ZH8-013YA	*R280*.....POWER RED	1	-	-	-	4363433 QB26	
							4363433 VSX, VSX1	
							AR, DKR, DS, HHQ4, HTF2, HT2, HX, HXU, HX2, HX26, HX4, KR, KRA4, KRF4, KRS4 KRS5, KRS6, KRT, KRT4, KRT6, LD, LH, LHQ4, LJ, LJC, LJS, LSJ, LSJ4, LTJ LTK1, LTR, LTS, LX, LXU, LX2, LX4, PX, QA, QA2, QD, QH, QHQ4, QH26, QLL, QM QMA4, QMA8, QME4, QMX2, QX, QXC9, QXS2, QXU, QX2, QX26, QX4, QX7, RD, RD4 RHC, RHQ4, RX, RX4, SAJ, SAJ4, SCJ, SD, SD16, SD4, SE, SH, SHQ4, SJ, SJC1 SJC5, SKR, SMA7, SMJ, SMW2, STP, STS, SX, SXS4, SX4, SX7, TX, TX2, TX26, TX4 UXU, VED, VED1, VET, VEX, VEX7, VMS4, VMT, VPM4, VPR4, VSX, VSX1, VX, VXU VX4, VX7, WDA6, WD12, WJ, WJP, WKD6, WKT2, WKT4, WKT6, WMA3, WME2, WME4 WM1	
			-	(1)	-	-	4363433	
			-	-	1	1		

Ref. No.	Part No.	Description	Reqd. QTY				Serial No.	Parts catalogue code
			(1)	(2)	(3)	(4)		
2	28410-ZH8-003YA	CASE COMP., RECOIL STARTER *R280*.....POWER RED	1	-	-	-	4363433	AR,DKR,DS,HHQ4,HTF2,HT2,HX,HXU,HX2,HX26,HX4,KR,KRA4,KRF4,KRS4 KRS5,KRS6,KRT,KRT4,KRT6,LAJ,LAJ4,LD,LH,LHQ4,LJ,LJC,LJS,LSJ LSJ4,LTJ,LTK1,LTR,LTS,LX,LXU,LX2,LX4,PX,QA,QA2,QD,QH,QHQ4,QH26 QLL,QM,QMA4,QMA8,QME4,QMX2,QX,QXC9,QXS2,QXU,QX2,QX26,QX4,QX7 RD,RD4,RHC,RHQ4,RX,RX4,SAJ,SAJ4,SCJ,SD,SD16,SD4,SE,SH,SHQ4,SJ SJC1,SJC5,SKR,SMA7,SMJ,SMW2,STP,STS,SX,SXS4,SX4,SX7,TX,TX2 TX26,TX4,UXU,VED,VED1,VET,VEX,VEX7,VMS4,VMT,VPM4,VPR4,VSX,VSX1 VX,VXU,VX4,VX7,WDA6,WD12,WJ,WJP,WKD6,WKT2,WKT4,WKT6,WMA3,WME2 WME4,WM1
			-	(1)	-	-	4363433	
	28410-ZH8-003ZB	*NH1*.....BLACK	1	-	-	1	4363433	AR,HX2,KR,PX2,QMX2,QWA4,QXC9,QXS2,QXU,QX2,SG24,SM11,SM12,SM14 SSK1,SSK3,SSX2,SSX4,TX4,VED,VED1,VED6,VEE1,VSX,VSX1
			-	(1)	-	-	4363433	
	28410-ZH8-003ZG	*NH105*...MAT BLACK (#15-#20)	1	-	-	-	4363433	LJD2,QJG2,SJD2,SWX2,SWX4
	28410-ZH8-003ZJ	*T51*.....JACOBSEN ORANGE	1	-	-	-	4363433	QJG2
	28410-ZH8-003ZK	*NH31*.....MCKINLEY WHITE	1	-	-	-	4363433	VEK
	28410-ZH8-003ZV	*T79*.....BOMBARDIER YELLOW	1	-	-	-	4363433	QB26
	28410-ZH8-003ZW	*T80*.....BAKELITE ORANGE	1	-	-	-	4363433	VSX,VSX1
3	28420-ZH8-013	REEL, RECOIL STARTER (NATURAL)	1	-	-	-	4363433	AR,DKR,DS,HHQ4,HTF2,HT2,HX,HXU,HX2,HX26,HX4,KR,KRA4,KRF4,KRS4 KRS5,KRS6,KRT,KRT4,KRT6,LAJ,LAJ4,LD,LH,LHQ4,LJ,LJC,LJD2,LJS LSJ,LSJ4,LTJ,LTK1,LTR,LTS,LX,LXU,LX2,LX4,PX,PX2,QA,QA2,QB26,QD QH,QHQ4,QH26,QJG2,QLL,QM,QMA4,QMA8,QME4,QMX2,QWA4,QX,QXC9,QXS2 QXU,QX2,QX26,QX4,QX7,RD,RD4,RHC,RHQ4,RX,RX4,SAJ,SAJ4,SCJ,SD SD16,SD4,SE,SG24,SH,SHQ4,SJ,SJC1,SJC5,SJD2,SKR,SMA7,SMJ,SMW2 SM11,SM12,SM14,SSK1,SSK3,SSX2,SSX4,STP,STS,SWX2,SWX4,SX,SXS4 SX4,SX7,TX,TX2,TX26,TX4,UXU,VED,VED1,VED6,VEE1,VEK,VET,VEX VEX7,VMS4,VMT,VPM4,VPR4,VSX,VSX1,VX,VXU,VX4,VX7,WDA6,WD12,WJ WJP,WKD6,WKT2,WKT4,WKT6,WMA3,WME2,WME4,WM1
			-	(1)	-	-	4363433	
			-	-	1	1		
4	28422-ZH8-013	RATCHET, STARTER	2	-	-	-	4363433	AR,DKR,DS,HHQ4,HTF2,HT2,HX,HXU,HX2,HX26,HX4,KR,KRA4,KRF4,KRS4 KRS5,KRS6,KRT,KRT4,KRT6,LAJ,LAJ4,LD,LH,LHQ4,LJ,LJC,LJD2,LJS LSJ,LSJ4,LTJ,LTK1,LTR,LTS,LX,LXU,LX2,LX4,PX,PX2,QA,QA2,QB26,QD QH,QHQ4,QH26,QJG2,QLL,QM,QMA4,QMA8,QME4,QMX2,QWA4,QX,QXC9,QXS2 QXU,QX2,QX26,QX4,QX7,RD,RD4,RHC,RHQ4,RX,RX4,SAJ,SAJ4,SCJ,SD SD16,SD4,SE,SG24,SH,SHQ4,SJ,SJC1,SJC5,SJD2,SKR,SMA7,SMJ,SMW2 SM11,SM12,SM14,SSK1,SSK3,SSX2,SSX4,STP,STS,SWX2,SWX4,SX,SXS4 SX4,SX7,TX,TX2,TX26,TX4,UXU,VED,VED1,VED6,VEE1,VEK,VET,VEX VEX7,VMS4,VMT,VPM4,VPR4,VSX,VSX1,VX,VXU,VX4,VX7,WDA6,WD12,WJ WJP,WKD6,WKT2,WKT4,WKT6,WMA3,WME2,WME4,WM1
			-	(2)	-	-	4363433	
			-	-	2	2		
5	28433-ZH8-003	GUIDE, RATCHET	1	-	-	-	4363433	AR,DKR,DS,HHQ4,HTF2,HT2,HX,HXU,HX2,HX26,HX4,KR,KRA4,KRF4,KRS4 KRS5,KRS6,KRT,KRT4,KRT6,LAJ,LAJ4,LD,LH,LHQ4,LJ,LJC,LJD2,LJS LSJ,LSJ4,LTJ,LTK1,LTR,LTS,LX,LXU,LX2,LX4,PX,PX2,QA,QA2,QB26,QD QH,QHQ4,QH26,QJG2,QLL,QM,QMA4,QMA8,QME4,QMX2,QWA4,QX,QXC9,QXS2 QXU,QX2,QX26,QX4,QX7,RD,RD4,RHC,RHQ4,RX,RX4,SAJ,SAJ4,SCJ,SD SD16,SD4,SE,SG24,SH,SHQ4,SJ,SJC1,SJC5,SJD2,SKR,SMA7,SMJ,SMW2 SM11,SM12,SM14,SSK1,SSK3,SSX2,SSX4,STP,STS,SWX2,SWX4,SX,SXS4 SX4,SX7,TX,TX2,TX26,TX4,UXU,VED,VED1,VED6,VEE1,VEK,VET,VEX VEX7,VMS4,VMT,VPM4,VPR4,VSX,VSX1,VX,VXU,VX4,VX7,WDA6,WD12,WJ WJP,WKD6,WKT2,WKT4,WKT6,WMA3,WME2,WME4,WM1
			-	(1)	-	-	4363433	
			-	-	1	1		



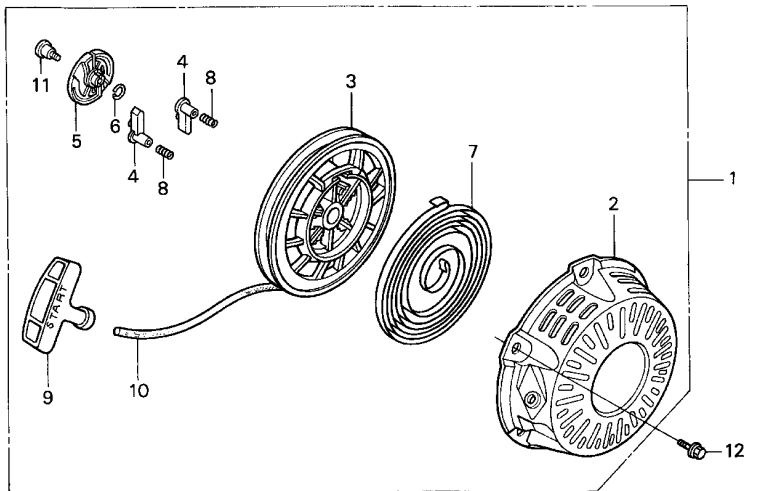

ZK70-E1100



Ref. No.	Part No.	Description	Reqd. QTY				Serial No.	Parts catalogue code
			(1)	(2)	(3)	(4)		
6	28441-ZH8-003	SPRING, FRICTION	1	-	-	-	4363433	AR,DKR,DS,HHQ4,HTF2,HT2,HX,HXU,HX2,HX26,HX4,KR,KRA4,KRF4,KRS4 KRS5,KRS6,KRT,KRT4,KRT6,LAJ,LAJ4,LD,LH,LHQ4,LJ,LJC,LJD2,LJS LSJ,LSJ4,LTJ,LTK1,LTR,LTS,LX,LXU,LX2,LX4,PX,PX2,QA,QA2,QB26,QD QH,QHQ4,QH26,QJG2,QLL,QM,QMA4,QMA8,QME4,QMX2,QWA4,QX,QXC9,QXS2 QXU,QX2,QX26,QX4,QX7,RD,RD4,RHC,RHQ4,RX,RX4,SAJ,SAJ4,SCJ,SD SD16,SD4,SE,SG24,SH,SHQ4,SJ,SJC1,SJC5,SJD2,SKR,SMA7,SMJ,SMW2 SM11,SM12,SM14,SSK1,SSK3,SSX2,SSX4,STP,STS,SWX2,SWX4,SX,SXS4 SX4,SX7,TX,TX2,TX26,TX4,UXU,VED,VED1,VED6,VEE1,VEK,VEK,VEK VEX7,VMS4,VMT,VPM4,VPR4,VSX,VSX1,VX,VXU,VX4,VX7,WDA6,WD12,WJ WJP,WKD6,WKT2,WKT4,WKT6,WMA3,WME2,WME4,WM1
			-	(1)	-	-	4363433	
			-	-	1	1		
7	28442-ZH8-003	SPRING, RECOIL STARTER	1	-	-	-	4363433	AR,DKR,DS,HHQ4,HTF2,HT2,HX,HXU,HX2,HX26,HX4,KR,KRA4,KRF4,KRS4 KRS5,KRS6,KRT,KRT4,KRT6,LAJ,LAJ4,LD,LH,LHQ4,LJ,LJC,LJD2,LJS LSJ,LSJ4,LTJ,LTK1,LTR,LTS,LX,LXU,LX2,LX4,PX,PX2,QA,QA2,QB26,QD QH,QHQ4,QH26,QJG2,QLL,QM,QMA4,QMA8,QME4,QMX2,QWA4,QX,QXC9,QXS2 QXU,QX2,QX26,QX4,QX7,RD,RD4,RHC,RHQ4,RX,RX4,SAJ,SAJ4,SCJ,SD SD16,SD4,SE,SG24,SH,SHQ4,SJ,SJC1,SJC5,SJD2,SKR,SMA7,SMJ,SMW2 SM11,SM12,SM14,SSK1,SSK3,SSX2,SSX4,STP,STS,SWX2,SWX4,SX,SXS4 SX4,SX7,TX,TX2,TX26,TX4,UXU,VED,VED1,VED6,VEE1,VEK,VEK,VEK VEX7,VMS4,VMT,VPM4,VPR4,VSX,VSX1,VX,VXU,VX4,VX7,WDA6,WD12,WJ WJP,WKD6,WKT2,WKT4,WKT6,WMA3,WME2,WME4,WM1
			-	(1)	-	-	4363433	
			-	-	1	1		

Ref. No.	Part No.	Description	Reqd. QTY				Serial No.	Parts catalogue code
			(1)	(2)	(3)	(4)		
8	28443-ZH8-003	SPRING, RETURN	2	-	-	-	4363433	AR,DKR,DS,HHQ4,HTF2,HT2,HX,HXU,HX2,HX26,HX4,KR,KRA4,KRF4,KRS4,KRS5,KRS6,KRT,KRT4,KRT6,LAJ,LAJ4,LD,LH,LHQ4,LJ,LJC,LJD2,LJS,LSJ,LSJ4,LTJ,LTJ4,LTJ,LTK1,LTR,LTS,LX,LXU,LX2,LX4,PX,PX2,QA,QA2,QB26,QD,QH,QHQ4,QH26,QJG2,QLL,QM,QMA4,QMA8,QME4,QMX2,QWA4,QX,QXC9,QXS2,QXU,QX2,QX26,QX4,QX7,RD,RD4,RHC,RHQ4,RX,RX4,SAJ,SAJ4,SCJ,SD,SD16,SD4,SE,SG24,SH,SHQ4,SJ,SJC1,SJC5,SJD2,SKR,SMA7,SMJ,SMW2,SM11,SM12,SM14,SSK1,SSK3,SSX2,SSX4,STP,STS,SWX2,SWX4,SX,SXS4,SX4,SX7,TX,TX2,TX26,TX4,UXU,VED,VED1,VED6,VEE1,VEK,VET,VEX,VEX7,VMS4,VMT,VPM4,VPR4,VSX,VSX1,VX,VXU,VX4,VX7,WDA6,WD12,WJ,WJP,WKD6,WKT2,WKT4,WKT6,WMA3,WME2,WME4,WM1
			-	(2)	-	-	4363433	
9	28461-ZH8-003	GRIP, STARTER	1	-	2	2	4363433	AR,DKR,DS,HHQ4,HTF2,HT2,HX,HXU,HX2,HX26,HX4,KR,KRA4,KRF4,KRS4,KRS5,KRS6,KRT,KRT4,KRT6,LAJ,LAJ4,LD,LH,LHQ4,LJ,LJC,LJD2,LJS,LSJ,LSJ4,LTJ,LTK1,LTR,LTS,LX,LXU,LX2,LX4,PX,PX2,QA,QA2,QB26,QD,QH,QHQ4,QH26,QJG2,QLL,QM,QMA4,QMA8,QME4,QMX2,QWA4,QX,QXC9,QXS2,QXU,QX2,QX26,QX4,QX7,RD,RD4,RHC,RHQ4,RX,RX4,SAJ,SAJ4,SCJ,SD,SD16,SD4,SE,SG24,SH,SHQ4,SJ,SJC1,SJC5,SJD2,SKR,SMA7,SMJ,SMW2,SM11,SM12,SM14,SSK1,SSK3,SSX2,SSX4,STP,STS,SWX2,SWX4,SX,SXS4,SX4,SX7,TX,TX2,TX26,TX4,UXU,VED,VED1,VED6,VEE1,VEK,VET,VEX,VEX7,VMS4,VMT,VPM4,VPR4,VSX,VSX1,VX,VXU,VX4,VX7,WDA6,WD12,WJ,WJP,WKD6,WKT2,WKT4,WKT6,WMA3,WME2,WME4,WM1
			-	(1)	-	-	4363433	
10	28462-ZH8-R10 28462-ZH8-003	ROPE, RECOIL STARTER	1	-	1	1	4363433	LAJ,LAJ4
			1	-	-	-	4363433	AR,DKR,DS,HHQ4,HTF2,HT2,HX,HXU,HX2,HX26,HX4,KR,KRA4,KRF4,KRS4,KRS5,KRS6,KRT,KRT4,KRT6,LD,LH,LHQ4,LJ,LJC,LJD2,LJS,LSJ,LSJ4,LTJ,LTK1,LTR,LTS,LX,LXU,LX2,LX4,PX,PX2,QA,QA2,QB26,QD,QH,QHQ4,QH26,QJG2,QLL,QM,QMA4,QMA8,QME4,QMX2,QWA4,QX,QXC9,QXS2,QXU,QX2,QX26,QX4,QX7,RD,RD4,RHC,RHQ4,RX,RX4,SAJ,SAJ4,SCJ,SD,SD16,SD4,SE,SG24,SH,SHQ4,SJ,SJC1,SJC5,SJD2,SKR,SMA7,SMJ,SMW2,SM11,SM12,SM14,SSK1,SSK3,SSX2,SSX4,STP,STS,SWX2,SWX4,SX,SXS4,SX4,SX7,TX,TX2,TX26,TX4,UXU,VED,VED1,VED6,VEE1,VEK,VET,VEX,VEX7,VMS4,VMT,VPM4,VPR4,VSX,VSX1,VX,VXU,VX4,VX7,WDA6,WD12,WJ,WJP,WKD6,WKT2,WKT4,WKT6,WMA3,WME2,WME4,WM1
			-	(1)	-	-	4363433	
	28470-816-000	ROPE, STARTER	-	(1)	-	-	4363433	
11	90003-ZH8-003	SCREW, SETTING	1	-	-	-	4363433	AR,DKR,DS,HHQ4,HTF2,HT2,HX,HXU,HX2,HX26,HX4,KR,KRA4,KRF4,KRS4,KRS5,KRS6,KRT,KRT4,KRT6,LAJ,LAJ4,LD,LH,LHQ4,LJ,LJC,LJD2,LJS,LSJ,LSJ4,LTJ,LTK1,LTR,LTS,LX,LXU,LX2,LX4,PX,PX2,QA,QA2,QB26,QD,QH,QHQ4,QH26,QJG2,QLL,QM,QMA4,QMA8,QME4,QMX2,QWA4,QX,QXC9,QXS2,QXU,QX2,QX26,QX4,QX7,RD,RD4,RHC,RHQ4,RX,RX4,SAJ,SAJ4,SCJ,SD,SD16,SD4,SE,SG24,SH,SHQ4,SJ,SJC1,SJC5,SJD2,SKR,SMA7,SMJ,SMW2,SM11,SM12,SM14,SSK1,SSK3,SSX2,SSX4,STP,STS,SWX2,SWX4,SX,SXS4,SX4,SX7,TX,TX2,TX26,TX4,UXU,VED,VED1,VED6,VEE1,VEK,VET,VEX,VEX7,VMS4,VMT,VPM4,VPR4,VSX,VSX1,VX,VXU,VX4,VX7,WDA6,WD12,WJ,WJP,WKD6,WKT2,WKT4,WKT6,WMA3,WME2,WME4,WM1
			-	(1)	-	-	4363433	
			-	-	1	1		



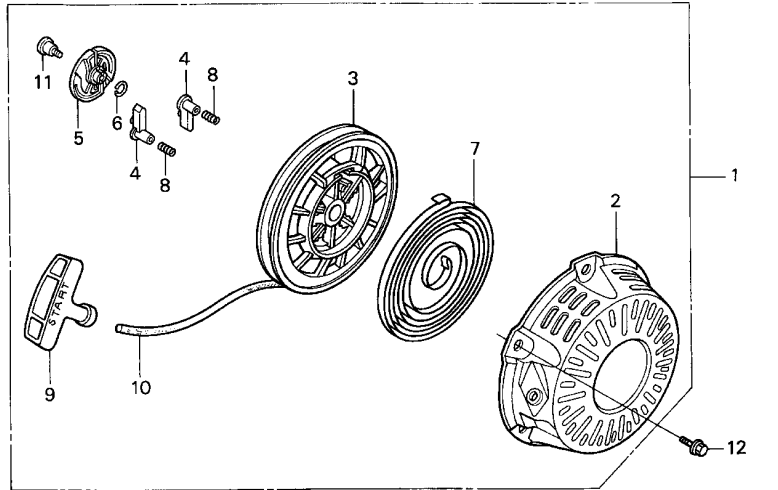

ZK70-E1100



Ref. No.	Part No.	Description	Reqd. QTY				Serial No.	Parts catalogue code
			(1)	GX120K1 (2)	(3)	(4)		
12	90008-ZE2-003	BOLT, FLANGE, 6X10	3	-	-	-	4363433	AR,DKR,DS,HHQ4,HTF2,HT2,HX,HXU,HX2,HX26,HX4,KR,KRA4,KRF4,KRS4,KRS5,KRS6,KRT,KRT4,KRT6,LAJ,LAJ4,LD,LH,LHQ4,LJ,LJC,LJD2,LJS,LSJ,LSJ4,LTJ,LTK1,LTR,LTS,LX,LXU,LX2,LX4,PX,PX2,QA,QA2,QB26,QD,QH,QHQ4,QH26,QJG2,QLL,QM,QMA4,QMA8,QME4,QMX2,QWA4,QX,QXC9,QXS2,QXU,QX2,QX26,QX4,QX7,RD,RD4,RHC,RHQ4,RX,RX4,SAJ,SAJ4,SCJ,SD,SD16,SD4,SE,SG24,SH,SHQ4,SJ,SJC1,SJC5,SJD2,SKR,SMA7,SMJ,SMW2,SM11,SM12,SM14,SSK1,SSK3,SSX2,SSX4,STP,STS,SWX2,SWX4,SX,SXS4,SX4,SX7,TX,TX2,TX26,TX4,UXU,VED,VED1,VED6,VEE1,VEK,VET,VEX,VEX7,VMS4,VMT,VPM4,VPR4,VSX,VSX1,VX,VXU,VX4,VX7,WDA6,WD12,WJ,WJP,WKD6,WKT2,WKT4,WKT6,WMA3,WME2,WME4,WM1
			-	(3)	-	-	4363433	
			-	-	3	3		

E-11-1

RECOIL STARTER(2)

F10

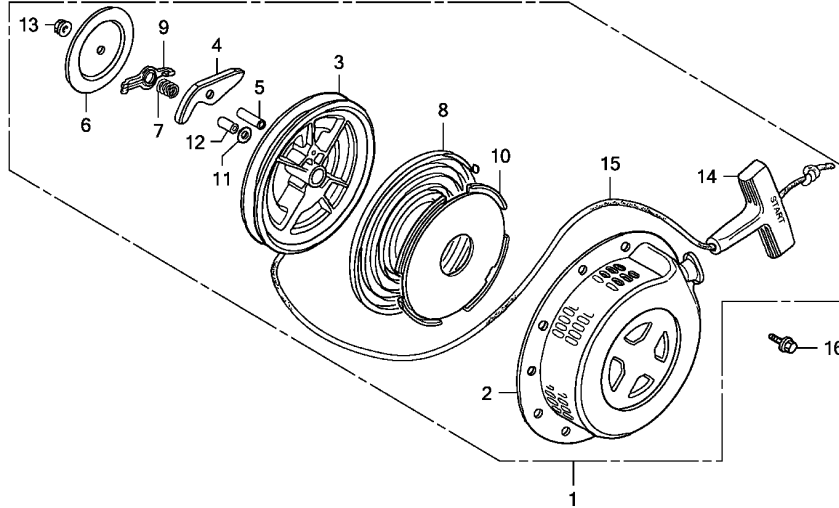

ZK70E1101A

Ref. No.	L.O.N.	(Relative ref. Number) Description	F.R.T.
1	1121B9	STARTER, RECOIL	0.1
3	1121B1	REEL, RECOIL STARTER	0.3
4	1121B0	RATCHET, STARTER AND/OR SPRING, RATCHET	0.2
6		(7,9)	
	1121A4	GUIDE, RATCHET	0.2
8	1121B7	SPRING, RECOIL STARTER RETURN	0.3
15	1121B3	ROPE, RECOIL STARTER	0.3

Ref. No.	Part No.	Description	Reqd. QTY				Serial No.	Parts catalogue code
			(1)	GX120K1 (2)	(3)	(4)		
1	28400-ZE1-003ZF	STARTER ASSY., RECOIL *R280*.....POWER RED	1	-	-	-	-----	QT
2	28410-ZE1-003ZF	CASE COMP., RECOIL STARTER *R280*.....POWER RED	1	-	-	-	-----	QT
3	28420-ZE1-003	PULLEY, RECOIL STARTER	1	-	-	-	-----	QT
4	28422-ZE1-003	RATCHET, STARTER	1	-	-	-	-----	QT
5	28423-ZE1-003	PIN, STARTER RATCHET	1	-	-	-	-----	QT
6	28431-ZE1-003	PLATE, FRICTION	1	-	-	-	-----	QT
7	28441-ZE1-003	SPRING, FRICTION	1	-	-	-	-----	QT
8	28442-ZE1-003	SPRING, RECOIL STARTER	1	-	-	-	-----	QT
9	28443-ZE1-003	GUIDE, RATCHET	1	-	-	-	-----	QT
10	28445-ZE1-003	CASE, RECOIL STARTER SPRING	1	-	-	-	-----	QT
11	28446-ZE1-003	WASHER, STARTER	1	-	-	-	-----	QT
12	28447-ZE1-003	SHAFT, SUB	1	-	-	-	-----	QT
13	28448-ZE1-003	NUT	1	-	-	-	-----	QT
14	28461-ZE1-003	KNOB, RECOIL STARTER	1	-	-	-	-----	QT
15	28462-ZE1-003	ROPE, RECOIL STARTER	1	-	-	-	-----	QT
16	90008-ZE2-003	BOLT, FLANGE, 6X10	3	-	-	-	-----	QT

2

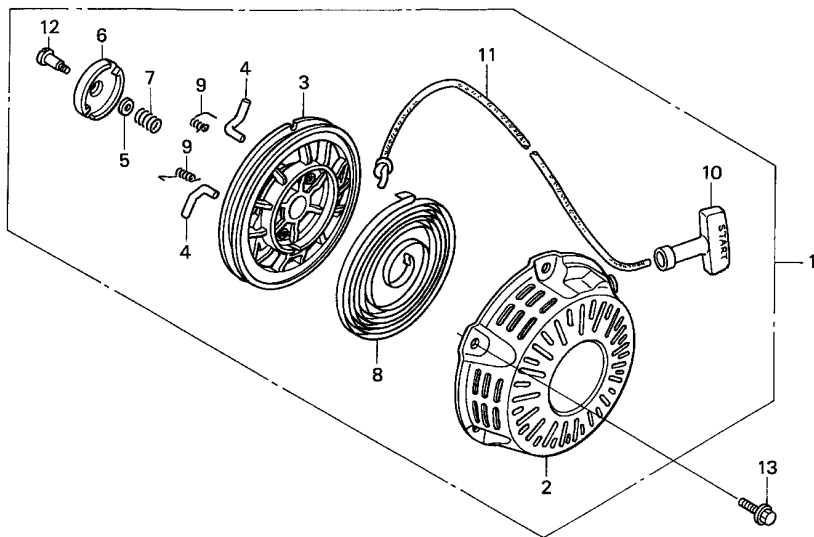

ZK70-E1102

Ref. No.	L.O.N.	(Relative ref. Number) Description	F.R.T.
1	1121B9	STARTER, RECOIL	0.1
3	1121B1	REEL, RECOIL STARTER	0.3
4	1121B0	RATCHET, STARTER AND/OR SPRING, RATCHET	0.2
6	1121A4	GUIDE, RATCHET	0.2
8	1121B7	SPRING, RECOIL STARTER RETURN	0.3
11	1121B3	ROPE, RECOIL STARTER	0.3

2

Ref. No.	Part No.	Description	Reqd. QTY				Serial No.	Parts catalogue code
			(1)	GX120K1 (2)	(3)	(4)		
1	28400-ZH8-R11ZA	STARTER ASSY., RECOIL (TURFCO) *R280*.....POWER RED	1	-	-	-	4363434	----- LAJ,LAJ4
	28400-ZH8-023YA	STARTER ASSY., RECOIL *R280*.....POWER RED	1	-	-	-	4363434	----- ARL,LJC8,SAR4,WMA4,WMK AR,DKR,DS,HHQ4,HTF2,HT2,HX,HXU,HX2,HX26,HX4,KR,KRA4,KRF4,KRS4 KRS5,KRS6,KRT,KRT4,KRT6,LD,LH,LHQ4,LJ,LJC,LJS,LSJ,LSJ4,LTJ LTK1,LTR,LTS,LX,LXU,LX2,LX4,PX,QA,QA2,QD,QH,QHQ4,QH26,QLL,QM QMA4,QMA8,QME4,QMX2,QX,QXC9,QXS2,QXU,QX2,QX26,QX4,QX7,RD,RD4 RHC,RHQ4,RX,RX4,SAJ,SAJ4,SCJ,SD,SD16,SD4,SE,SH,SHQ4,SJ,SJC1 SJC5,SKR,SMA7,SMJ,SMW2,STP,STS,SX,SXS4,SX4,SX7,TX,TX2,TX26,TX4 UXU,VED,VED1,VET,VEX,VEX7,VMS4,VMT,VPM4,VPR4,VSX,VSX1,VX,VXU VX4,VX7,WDA6,WD12,WJ,WJP,WKD6,WKT2,WKT4,WKT6,WMA3,WME2,WME4 WM1
	28400-ZH8-023ZB	*NH1*.....BLACK	1	-	-	-	4363434	----- ARL,HT24,SYA AR,HX2,KR,PX2,QMX2,QWA4,QXC9,QXS2,QXU,QX2,SG24,SM11,SM12,SM14 SSK1,SSK3,SSX2,SSX4,TX4,VED,VED1,VED6,VEE1,VSX,VSX1
	28400-ZH8-023ZG	*NH105*...MAT BLACK (#15-#20)	1	-	-	-	4363434	----- LJD2,QJG2,SJD2,SWX2,SWX4
	28400-ZH8-023ZJ	*T51*.....JACOBSEN ORANGE	1	-	-	-	4363434	----- QJG2
	28400-ZH8-023ZK	*NH31*.....MCKINLEY WHITE	1	-	-	-	4363434	----- VEK
	28400-ZH8-023ZV	*T79*.....BOMBARDIER YELLOW	1	-	-	-	4363434	----- QB26
	28400-ZH8-023ZW	*T80*.....BAKELITE ORANGE	1	-	-	-	4363434	----- VSX,VSX1

Ref. No.	Part No.	Description	Reqd. QTY				Serial No.	Parts catalogue code
			(1)	(2)	(3)	(4)		
2	28410-ZH8-003YA	CASE COMP., RECOIL STARTER *R280*.....POWER RED	1	-	-	-	4363434	ARL,LJC8,SAR4,WMA4,WMK AR,DKR,DS,HHQ4,HTF2,HT2,HX,HXU,HX2,HX26,HX4,KR,KRA4,KRF4,KRS4 KRS5,KRS6,KRT,KRT4,KRT6,LAJ,LAJ4,LD,LH,LHQ4,LJ,LJC,LJS,LSJ LSJ4,LTJ,LTK1,LTR,LTS,LX,LXU,LX2,LX4,PX,QA,QA2,QD,QH,QHQ4,QH26 QLL,QM,QMA4,QMA8,QME4,QMX2,QX,QXC9,QXS2,QXU,QX2,QX26,QX4,QX7 RD,RD4,RHC,RHQ4,RX,RX4,SAJ,SAJ4,SCJ,SD,SD16,SD4,SE,SH,SHQ4,SJ SJC1,SJC5,SKR,SMA7,SMJ,SMW2,STP,STS,SX,SXS4,SX4,SX7,TX,TX2 TX26,TX4,UXU,VED,VED1,VET,VEX,VEX7,VMS4,VMT,VPM4,VPR4,VSX,VSX1 VX,VXU,VX4,VX7,WDA6,WD12,WJ,WJP,WKD6,WKT2,WKT4,WKT6,WMA3,WME2 WME4,WM1
			-	(1)	-	-	4363434	
			-	-	1	1		
	28410-ZH8-003ZB	*NH1*.....BLACK	1	-	-	-	4363434	ARL,HT24,SYA AR,HX2,KR,PX2,QMX2,QWA4,QXC9,QXS2,QXU,QX2,SG24,SM11,SM12,SM14 SSK1,SSK3,SSX2,SSX4,TX4,VED,VED1,VED6,VEE1,VSX,VSX1
			-	(1)	-	-	4363434	
	28410-ZH8-003ZG	*NH105*...MAT BLACK (#15-#20)	1	-	-	-	4363434	LJD2,QJG2,SJD2,SWX2,SWX4
	28410-ZH8-003ZJ	*T51*.....JACOBSEN ORANGE	1	-	-	-	4363434	QJG2
	28410-ZH8-003ZK	*NH31*.....MCKINLEY WHITE	1	-	-	-	4363434	VEK
	28410-ZH8-003ZV	*T79*.....BOMBARDIER YELLOW	1	-	-	-	4363434	QB26
	28410-ZH8-003ZW	*T80*.....BAKELITE ORANGE	1	-	-	-	4363434	VSX,VSX1
3	28421-ZH8-801	REEL, RECOIL STARTER	1	-	-	-	4363434	ARL,HT24,LJC8,SAR4,SYA,WMA4,WMK AR,DKR,DS,HHQ4,HTF2,HT2,HX,HXU,HX2,HX26,HX4,KR,KRA4,KRF4,KRS4 KRS5,KRS6,KRT,KRT4,KRT6,LAJ,LAJ4,LD,LH,LHQ4,LJ,LJC,LJD2,LJS LSJ,LSJ4,LTJ,LTK1,LTR,LTS,LX,LXU,LX2,LX4,PX,PX2,QA,QA2,QB26,QD QH,QHQ4,QH26,QJG2,QLL,QM,QMA4,QMA8,QME4,QMX2,QWA4,QX,QXC9,QXS2 QXU,QX2,QX26,QX4,QX7,RD,RD4,RHC,RHQ4,RX,RX4,SAJ,SAJ4,SCJ,SD SD16,SD4,SE,SG24,SH,SHQ4,SJ,SJC1,SJC5,SJD2,SKR,SMA7,SMJ,SMW2 SM11,SM12,SM14,SSK1,SSK3,SSX2,SSX4,STP,STS,SWX2,SWX4,SX,SXS4 SX4,SX7,TX,TX2,TX26,TX4,UXU,VED,VED1,VED6,VEE1,VEK,VET,VEX VEX7,VMS4,VMT,VPM4,VPR4,VSX,VSX1,VX,VXU,VX4,VX7,WDA6,WD12,WJ WJP,WKD6,WKT2,WKT4,WKT6,WMA3,WME2,WME4,WM1
			-	(1)	-	-	4363634	
			-	-	1	1		
4	28422-ZH8-801	RATCHET, STARTER	2	-	-	-	4363434	ARL,HT24,LJC8,SAR4,SYA,WMA4,WMK AR,DKR,DS,HHQ4,HTF2,HT2,HX,HXU,HX2,HX26,HX4,KR,KRA4,KRF4,KRS4 KRS5,KRS6,KRT,KRT4,KRT6,LAJ,LAJ4,LD,LH,LHQ4,LJ,LJC,LJD2,LJS LSJ,LSJ4,LTJ,LTK1,LTR,LTS,LX,LXU,LX2,LX4,PX,PX2,QA,QA2,QB26,QD QH,QHQ4,QH26,QJG2,QLL,QM,QMA4,QMA8,QME4,QMX2,QWA4,QX,QXC9,QXS2 QXU,QX2,QX26,QX4,QX7,RD,RD4,RHC,RHQ4,RX,RX4,SAJ,SAJ4,SCJ,SD SD16,SD4,SE,SG24,SH,SHQ4,SJ,SJC1,SJC5,SJD2,SKR,SMA7,SMJ,SMW2 SM11,SM12,SM14,SSK1,SSK3,SSX2,SSX4,STP,STS,SWX2,SWX4,SX,SXS4 SX4,SX7,TX,TX2,TX26,TX4,UXU,VED,VED1,VED6,VEE1,VEK,VET,VEX VEX7,VMS4,VMT,VPM4,VPR4,VSX,VSX1,VX,VXU,VX4,VX7,WDA6,WD12,WJ WJP,WKD6,WKT2,WKT4,WKT6,WMA3,WME2,WME4,WM1
			-	(2)	-	-	4363434	
			-	-	2	2		



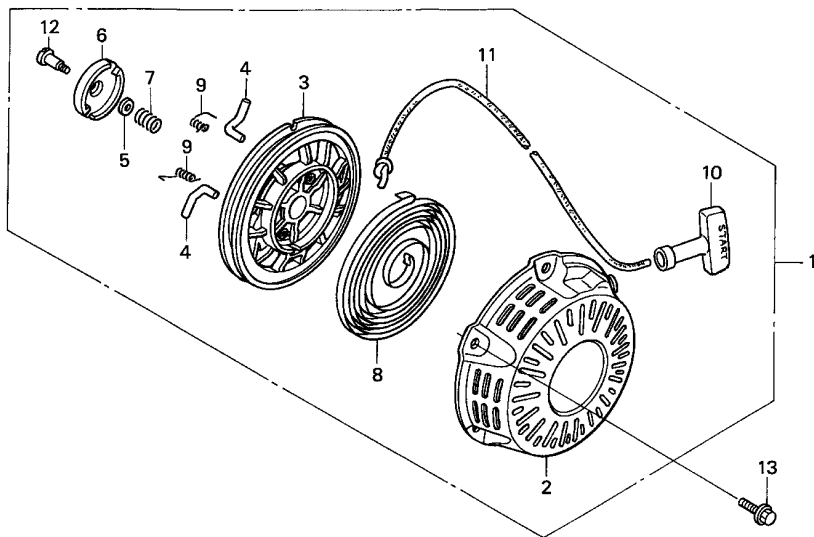

ZK70-E1102



Ref. No.	Part No.	Description	Reqd. QTY				Serial No.	Parts catalogue code
			(1)	GX120K1 (2)	(3)	(4)		
5	28431-ZH8-801	PLATE, FRICTION	1	-	-	-	-----	ARL,HT24,LJC8,SAR4,SYA,WMA4,WMK
			1	-	-	-	4363434	-----
			-	(1)	-	-	4363434	-----
			-	-	1	1		
6	28433-ZH8-801	GUIDE, RATCHET	1	-	-	-	-----	ARL,HT24,LJC8,SAR4,SYA,WMA4,WMK
			1	-	-	-	4363434	-----
			-	(1)	-	-	4363434	-----
			-	-	1	1		

Ref. No.	Part No.	Description	Reqd. QTY				Serial No.	Parts catalogue code
			(1)	(2)	(3)	(4)		
7	28441-ZH8-801	SPRING, FRICTION	1	-	-	-	-----	ARL,HT24,LJC8,SAR4,SYA,WMA4,WMK
			1	-	-	-	4363434	----- AR,DKR,DS,HHQ4,HTF2,HT2,HX,HXU,HX2,HX26,HX4,KR,KRA4,KRF4,KRS4 KRS5,KRS6,KRT,KRT4,KRT6,LAJ,LAJ4,LD,LH,LHQ4,LJ,LJC,LJD2,LJS LSJ,LSJ4,LTJ,LTK1,LTR,LTS,LX,LXU,LX2,LX4,PX,PX2,QA,QA2,QB26,QD QH,QHQ4,QH26,QJG2,QLL,QM,QMA4,QMA8,QME4,QMX2,QWA4,QX,QXC9,QXS2 QXU,QX2,QX26,QX4,QX7,RD,RD4,RHC,RHQ4,RX,RX4,SAJ,SAJ4,SCJ,SD SD16,SD4,SE,SG24,SH,SHQ4,SJ,SJC1,SJC5,SJD2,SKR,SMA7,SMJ,SMW2 SM11,SM12,SM14,SSK1,SSK3,SSX2,SSX4,STP,STS,SWX2,SWX4,SX,SXS4 SX4,SX7,TX,TX2,TX26,TX4,UXU,VED,VED1,VED6,VEE1,VEK,VET,VEX VEX7,VMS4,VMT,VPM4,VPR4,VSX,VSX1,VX,VXU,VX4,VX7,WDA6,WD12,WJ WJP,WKD6,WKT2,WKT4,WKT6,WMA3,WME2,WME4,WM1
			-	(1)	-	-	4363434	
			-	-	1	1		
8	28442-ZH8-003	SPRING, RECOIL STARTER	1	-	-	-	-----	ARL,HT24,LJC8,SAR4,SYA,WMA4,WMK
			1	-	-	-	4363434	----- AR,DKR,DS,HHQ4,HTF2,HT2,HX,HXU,HX2,HX26,HX4,KR,KRA4,KRF4,KRS4 KRS5,KRS6,KRT,KRT4,KRT6,LAJ,LAJ4,LD,LH,LHQ4,LJ,LJC,LJD2,LJS LSJ,LSJ4,LTJ,LTK1,LTR,LTS,LX,LXU,LX2,LX4,PX,PX2,QA,QA2,QB26,QD QH,QHQ4,QH26,QJG2,QLL,QM,QMA4,QMA8,QME4,QMX2,QWA4,QX,QXC9,QXS2 QXU,QX2,QX26,QX4,QX7,RD,RD4,RHC,RHQ4,RX,RX4,SAJ,SAJ4,SCJ,SD SD16,SD4,SE,SG24,SH,SHQ4,SJ,SJC1,SJC5,SJD2,SKR,SMA7,SMJ,SMW2 SM11,SM12,SM14,SSK1,SSK3,SSX2,SSX4,STP,STS,SWX2,SWX4,SX,SXS4 SX4,SX7,TX,TX2,TX26,TX4,UXU,VED,VED1,VED6,VEE1,VEK,VET,VEX VEX7,VMS4,VMT,VPM4,VPR4,VSX,VSX1,VX,VXU,VX4,VX7,WDA6,WD12,WJ WJP,WKD6,WKT2,WKT4,WKT6,WMA3,WME2,WME4,WM1
			-	(1)	-	-	4363434	
			-	-	1	1		
9	28443-ZH8-801	SPRING, RETURN	2	-	-	-	-----	ARL,HT24,LJC8,SAR4,SYA,WMA4,WMK
			2	-	-	-	4363434	----- AR,DKR,DS,HHQ4,HTF2,HT2,HX,HXU,HX2,HX26,HX4,KR,KRA4,KRF4,KRS4 KRS5,KRS6,KRT,KRT4,KRT6,LAJ,LAJ4,LD,LH,LHQ4,LJ,LJC,LJD2,LJS LSJ,LSJ4,LTJ,LTK1,LTR,LTS,LX,LXU,LX2,LX4,PX,PX2,QA,QA2,QB26,QD QH,QHQ4,QH26,QJG2,QLL,QM,QMA4,QMA8,QME4,QMX2,QWA4,QX,QXC9,QXS2 QXU,QX2,QX26,QX4,QX7,RD,RD4,RHC,RHQ4,RX,RX4,SAJ,SAJ4,SCJ,SD SD16,SD4,SE,SG24,SH,SHQ4,SJ,SJC1,SJC5,SJD2,SKR,SMA7,SMJ,SMW2 SM11,SM12,SM14,SSK1,SSK3,SSX2,SSX4,STP,STS,SWX2,SWX4,SX,SXS4 SX4,SX7,TX,TX2,TX26,TX4,UXU,VED,VED1,VED6,VEE1,VEK,VET,VEX VEX7,VMS4,VMT,VPM4,VPR4,VSX,VSX1,VX,VXU,VX4,VX7,WDA6,WD12,WJ WJP,WKD6,WKT2,WKT4,WKT6,WMA3,WME2,WME4,WM1
			-	(2)	-	-	4363434	
			-	-	2	2		
10	28461-ZH8-003	GRIP, STARTER	1	-	-	-	-----	ARL,HT24,LJC8,SAR4,SYA,WMA4,WMK
			1	-	-	-	4363434	----- AR,DKR,DS,HHQ4,HTF2,HT2,HX,HXU,HX2,HX26,HX4,KR,KRA4,KRF4,KRS4 KRS5,KRS6,KRT,KRT4,KRT6,LAJ,LAJ4,LD,LH,LHQ4,LJ,LJC,LJD2,LJS LSJ,LSJ4,LTJ,LTK1,LTR,LTS,LX,LXU,LX2,LX4,PX,PX2,QA,QA2,QB26,QD QH,QHQ4,QH26,QJG2,QLL,QM,QMA4,QMA8,QME4,QMX2,QWA4,QX,QXC9,QXS2 QXU,QX2,QX26,QX4,QX7,RD,RD4,RHC,RHQ4,RX,RX4,SAJ,SAJ4,SCJ,SD SD16,SD4,SE,SG24,SH,SHQ4,SJ,SJC1,SJC5,SJD2,SKR,SMA7,SMJ,SMW2 SM11,SM12,SM14,SSK1,SSK3,SSX2,SSX4,STP,STS,SWX2,SWX4,SX,SXS4 SX4,SX7,TX,TX2,TX26,TX4,UXU,VED,VED1,VED6,VEE1,VEK,VET,VEX VEX7,VMS4,VMT,VPM4,VPR4,VSX,VSX1,VX,VXU,VX4,VX7,WDA6,WD12,WJ WJP,WKD6,WKT2,WKT4,WKT6,WMA3,WME2,WME4,WM1
			-	(1)	-	-	4363434	
			-	-	1	1		
11	28462-ZH8-R10	ROPE, RECOIL STARTER	1	-	-	-	-----	LAJ,LAJ4



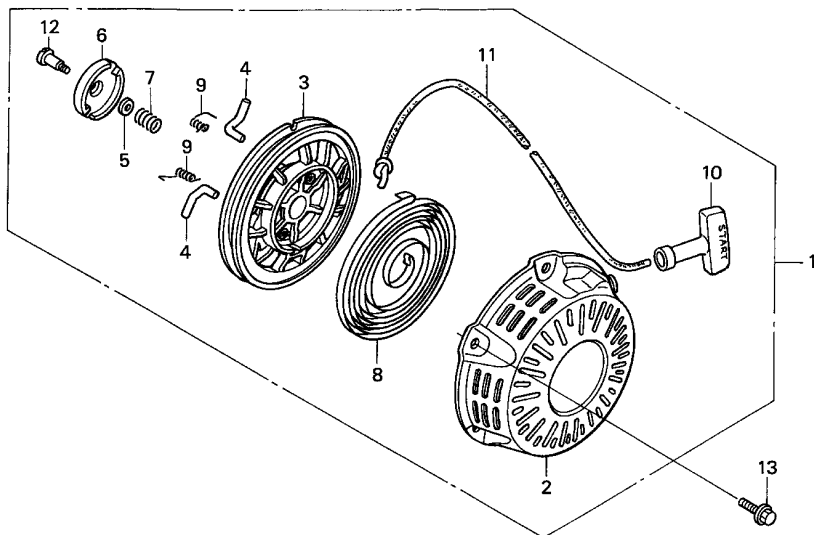

ZK70-E1102

Ref. No.	Part No.	Description	Reqd. QTY				Serial No.	Parts catalogue code
			(1)	GX120K1 (2)	(3)	(4)		
11)	28462-ZH8-003	ROPE, RECOIL STARTER	1	-	-	-	ARL,HT24,LJC8,SAR4,SYA,WMA4,WMK	
			1	-	-	-	4363434 ----- AR,DKR,DS,HHQ4,HTF2,HT2,HX,HXU,HX2,HX26,HX4,KR,KRA4,KRF4,KRS4 KRS5,KRS6,KRT,KRT4,KRT6,LD,LH,LHQ4,LJ,LJC,LJD2,LJS,LSJ,LSJ4 LTJ, LTK1, LTR, LTS, LX, LXU, LX2, LX4, PX, PX2, QA, QA2, QB26, QD, QH, QHQ4 QH26, QJG2, QLL, QM, QMA4, QMA8, QME4, QMX2, QWA4, QX, QXC9, QXS2, QXU, QX2 QX26, QX4, QX7, RD, RD4, RHC, RHQ4, RX, RX4, SAJ, SAJ4, SCJ, SD, SD16, SD4 SE, SG24, SH, SHQ4, SJ, SJC1, SJC5, SJD2, SKR, SMA7, SMJ, SMW2, SM11, SM12 SM14, SSK1, SSK3, SSX2, SSX4, STP, STS, SWX2, SWX4, SX, SXS4, SX4, SX7, TX TX2, TX26, TX4, UXU, VED, VED1, VED6, VEE1, VEK, VET, VEX, VEX7, VMS4, VMT VPM4, VPR4, VSX, VSX1, VX, VXU, VX4, VX7, WDA6, WD12, WJ, WJP, WKD6, WKT2 WKT4, WKT6, WMA3, WME2, WME4, WM1	
			-	(1)	-	-	4363434	
			-	-	1	1		
12	90003-ZH8-801	SCREW, SETTING	1	-	-	-	ARL,HT24,LJC8,SAR4,SYA,WMA4,WMK	
			1	-	-	-	4363434 ----- AR,DKR,DS,HHQ4,HTF2,HT2,HX,HXU,HX2,HX26,HX4,KR,KRA4,KRF4,KRS4 KRS5,KRS6,KRT,KRT4,KRT6,LAJ,LAJ4,LD,LH,LHQ4,LJ,LJC,LJD2,LJS LSJ,LSJ4,LTJ,LTK1, LTR, LTS, LX, LXU, LX2, LX4, PX, PX2, QA, QA2, QB26, QD QH, QHQ4, QH26, QJG2, QLL, QM, QMA4, QMA8, QME4, QMX2, QWA4, QX, QXC9, QXS2 QXU, QX2, QX26, QX4, QX7, RD, RD4, RHC, RHQ4, RX, RX4, SAJ, SAJ4, SCJ, SD SD16, SD4, SE, SG24, SH, SHQ4, SJ, SJC1, SJC5, SJD2, SKR, SMA7, SMJ, SMW2 SM11, SM12, SM14, SSK1, SSK3, SSX2, SSX4, STP, STS, SWX2, SWX4, SX, SXS4 SX4, SX7, TX, TX2, TX26, TX4, UXU, VED, VED1, VED6, VEE1, VEK, VET, VEX VEX7, VMS4, VMT, VPM4, VPR4, VSX, VSX1, VX, VXU, VX4, VX7, WDA6, WD12, WJ WJP, WKD6, WKT2, WKT4, WKT6, WMA3, WME2, WME4, WM1	
			-	(1)	-	-	4363434	
			-	-	1	1		

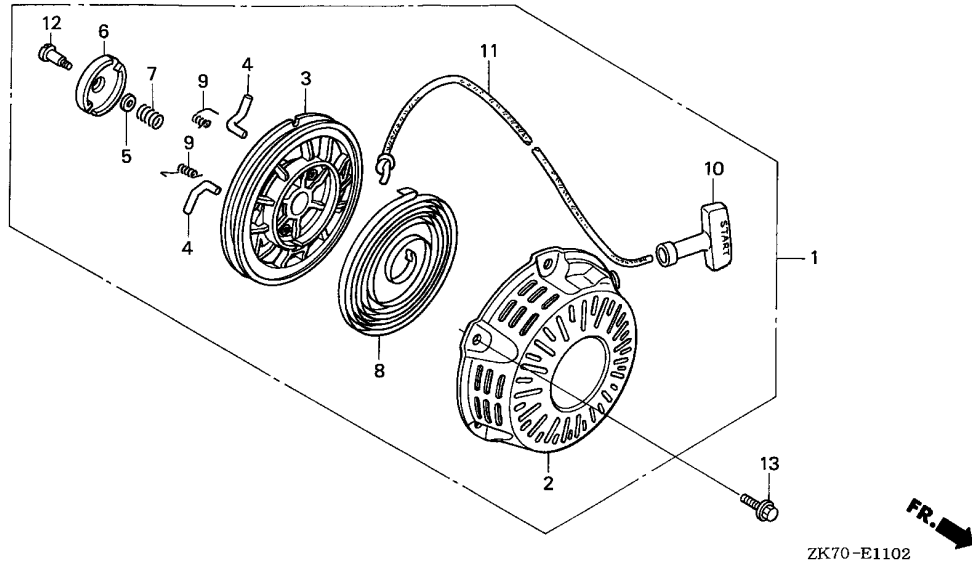

Ref. No.	Part No.	Description	Reqd. QTY				Serial No.	Parts catalogue code
			(1)	GX120K1 (2)	(3)	(4)		
13	90008-ZE2-003	BOLT, FLANGE, 6X10	3	-	-	-	ARL,HT24,LJC8,SAR4,SYA,WMA4,WMK	
			3	-	-	-	AR,DKR,DS,HHQ4,HTF2,HT2,HX,HXU,HX2,HX26,HX4,KR,KRA4,KRF4,KRS4,KRS5,KRS6,KRT,KRT4,KRT6,LAJ,LAJ4,LD,LH,LHQ4,LJ,LJC,LJD2,LJS,LSJ,LSJ4,LTJ,LTK1,LTR,LTS,LX,LXU,LX2,LX4,PX,PX2,QA,QA2,QB26,QD,QH,QHQ4,QH26,QJG2,QLL,QM,QMA4,QMA8,QME4,QMX2,QWA4,QX,QXC9,QXS2,QXU,QX2,QX26,QX4,QX7,RD,RD4,RHC,RHQ4,RX,RX4,SAJ,SAJ4,SCJ,SD,SD16,SD4,SE,SG24,SH,SHQ4,SJ,SJC1,SJC5,SJD2,SKR,SMA7,SMJ,SMW2,SM11,SM12,SM14,SSK1,SSK3,SSX2,SSX4,STP,STS,SWX2,SWX4,SX,SXS4,SX4,SX7,TX,TX2,TX26,TX4,UXU,VED,VED1,VED6,VEE1,VEK,VET,VEX,VEX7,VMS4,VMT,VPM4,VPR4,VSX,VSX1,VX,VXU,VX4,VX7,WDA6,WD12,WJ,WJP,WKD6,WKT2,WKT4,WKT6,WMA3,WME2,WME4,WM1	
			-	(3)	-	-	4363434	
			-	-	3	3		



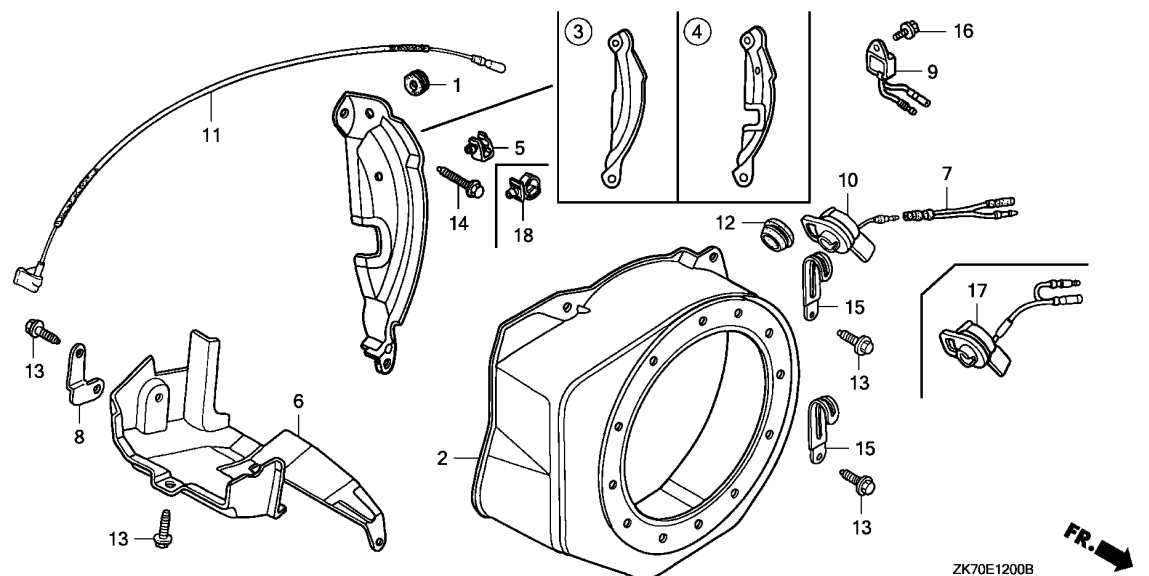

Ref. No.	L.O.N.	(Relative ref. Number) Description	F.R.T.
2	1141G8	COVER, ENGINE COOLING FAN ----	0.2
3		(4)	
	1121A7	PLATE, SIDE	0.3
6	4141E3	SHROUD, ENGINE	0.2
7	6111H1	SUB HARNESS, ENGINE SWITCH/ ENGINE STOP SWITCH	0.1
9	6151A0	ALERT UNIT, ENGINE OIL	0.1
10		(17)	
	6151D9	SWITCH, ENGINE STOP	0.2
11	6111B3	CORD, STOP SWITCH	0.3

2

Ref. No.	Part No.	Description	Reqd. QTY				Serial No.	Parts catalogue code
			(1)	GX120K1 (2)	(3)	(4)		
1	11347-371-300	GROMMET, ADJUSTING COVER ----	1	1	1	1		
2	19610-ZB0-6012D	COVER COMP., FAN						
	19610-ZE0-000ZE	*R280*.....POWER RED	1	-	-	-	LSJ4, SJC1, SJC5	
	19610-ZE0-000ZE	*NH1*.....BLACK	1	-	-	-	HT24, HX2, PX2, QMX2, QWA4, QXC9, QXU, QX2, SG24, SM11, SM12, SM14, SSK1	
	19610-ZE0-000ZF	*NH246*.....LOOSEY GRAY	1	-	-	-	SSK3, SSK2, SSK4, SYA, TX4, VED, VED1, VED6, VSX, VSX1	
	19610-ZE0-000ZG	*T51*.....JACOBSEN ORANGE	1	-	-	-	QXS2	
	19610-ZE0-000ZH	*NH31*.....MCKINLEY WHITE	1	-	-	-	QJG2	
	19610-ZE0-000ZK	*NH105*...MAT BLACK (#15-#20)	1	-	-	-	VEK	
	19610-ZE0-000ZP	*T73*.....EXEN GRAY	1	-	-	-	LJD2, QJG2, SJD2, SWX2, SWX4	
	19610-ZE0-000ZQ	*T79*.....BOMBARDIER YELLOW	1	-	-	-	VEE1	
	19610-ZE0-000ZR	*T80*.....BAKELITE ORANGE	1	-	-	-	QB26	
	19610-ZE0-000ZS	*R280*.....POWER RED	1	-	-	-	VSX, VSX1	
							DS, HHQ4, HTF2, HT2, HX, HXU, HX2, HX26, HX4, LAJ, LAJ4, LD, LH, LHQ4, LJ	
							LJC, LJC8, LJS, LSJ, LTJ, LTK1, LTR, LTS, LX, LXU, LX2, LX4, PX, QA, QA2, QD	
							QH, QHQ4, QH26, QLL, QM, QMA4, QMA8, QME4, QMX2, QT, QX, QXC9, QXS2, QXU	
							QX2, QX26, QX4, QX7, RD, RD4, RHC, RHQ4, RX, RX4, SAJ, SAJ4, SAR4, SCJ, SD	
							SD16, SD4, SE, SH, SHQ4, SJ, SKR, SMA7, SMJ, SMW2, STP, STS, SX, SXS4, SX4	
							SX7, TX, TX2, TX26, TX4, UXU, VED, VED1, VET, VEX, VEX7, VMS4, VMT, VPM4	
							VPR4, VSX, VSX1, VX, VXU, VX4, VX7, WDA6, WD12, WJ, WJP, WKD6, WKT2, WKT4	
							WKT6, WMA3, WMA4, WME2, WME4, WMK, WM1	
	19610-ZH7-V90ZB	*R280*.....POWER RED	-	(1)	1	1	KRT, KRT4, KRT6	
	19610-ZK7-V00ZB	*T73*.....EXEN GRAY	1	-	-	-	KR	
	19610-ZK7-V00ZC	*NH1*.....BLACK	1	-	-	-	AR, ARL, KR	
	19610-ZK7-V00ZD	*R280*.....POWER RED	1	-	-	-	AR, ARL, DKR, KR, KRA4, KRF4, KRS4, KRS5, KRS6	

Ref. No.	Part No.	Description	Reqd. QTY				Serial No.	Parts catalogue code
			(1)	(2)	(3)	(4)		
3	19611-ZH7-810	PLATE COMP., SIDE (OIL ALERT)	1	(1)	-	1	HTF2, HX, HXU, HX2, HX26, HX4, LJC, LJC8, LX, LXU, LX2, LX4, PX, PX2, QLL, QMA8, QMX2, QWA4, QX, QXBR, QXC9, QXU, QX2, QX26, QX4, QX7, Q1, RX, RX4, SG24, SJC1, SJC5, SMA7, SMJ, SMW2, SM12, SM14, SXS4, SWX2, SWX4, SXS4, SX4, SX7, S1, TX, TXBR, TX2, TX26, TX4, UXU, VED1, VED6, VEE1, VEX, VEX7, VMS4, VMT, VPM4, VPR4, VSX, VSX1, VX, VXBR, VXU, VX4, VX7, WKD6, WKT2, WKT4, WKT6, WME2, W1	
	19612-ZH7-000	PLATE, SIDE (STD.)	1	-	-	1	DS, HHQ4, HT2, HT24, LD, LH, LHQ4, LJ, LJD2, LSJ, LSJ4, LTJ, LTK1, LTR, LTS, QA, QA2, QD, QDBR, QH, QHQ4, QH26, QM, QMA4, QME4, QT, RD, RD4, RHQ4, SAJ, SAJ4, SAR4, SCJ, SD, SD16, SD4, SE, SH, SHQ4, SJ, SJD2, SKR, SM11, SSK1, SSK3, STP, STS, VED, VEK, VET, WDA6, WD12, WJ, WJP, WMA3, WMA4, WME4, WMK, WM1	
	19612-ZK7-V00	PLATE, SIDE	-	(1)	1	-	AR, ARL, DKR, KR, KRA4, KRF4, KRS4, KRS5, KRS6, KRT, KRT4, KRT6	
4	19611-ZH7-820	PLATE COMP., SIDE (ALERT & LAMP)	1	(1)	-	-	QXS2, R1	
	19612-ZH7-821	PLATE, SIDE	1	(1)	-	-	H1, LAJ, LAJ4, LJS, L1, QB26, QJG2, Q1, RHC, SYA, S1, W1	
5	19613-ZE1-020	CLAMP, CORD	1	-	-	-	VPR4	
6	19630-ZH7-000	SHROUD COMP.	1	-	-	-	DS, HHQ4, HTF2, HT2, HT24, HX, HXU, HX2, HX26, HX4, LAJ, LAJ4, LD, LH, LHQ4, LJ, LJC, LJC8, LJD2, LJS, LSJ, LSJ4, LTJ, LTK1, LTR, LTS, LX, LXU, LX2, LX4, PX, PX2, QA, QA2, QB26, QD, QH, QHQ4, QH26, QJG2, QLL, QM, QMA4, QMA8, QME4, QMX2, QT, QWA4, QX, QXC9, QXS2, QXU, QX2, QX26, QX4, QX7, RD, RD4, RHC, RHQ4, RX, RX4, SAJ, SAJ4, SAR4, SCJ, SD, SD16, SD4, SE, SG24, SH, SHQ4, SJ, SJC1, SJC5, SJD2, SKR, SMA7, SMJ, SMW2, SM11, SM12, SM14, SSK1, SSK3, SSS2, SSS4, STP, STS, SWX2, SWX4, SX, SXS4, SX4, SX7, SYA, TX, TX2, TX26, TX4, UXU, VED, VED1, VED6, VEE1, VEK, VET, VEX, VEX7, VMS4, VMT, VPM4, VPR4, VSX, VSX1, VX, VXU, VX4, VX7, WDA6, WD12, WJ, WJP, WKD6, WKT2, WKT4, WKT6, WMA3, WMA4, WME2, WME4, WMK, WM1	
7	32197-ZH8-003	SUB HARNESS	-	1	1	1	VPR4	
8	32303-ZE0-850	STAY, CORD CLIP	1	-	-	-	VEK	
9	34150-ZH7-003	ALERT UNIT, OIL	1	-	-	1	HTF2, HXU, HX2, HX26, HX4, LXU, LX2, LX4, PX2, QLL, QMA8, QMX2, QWA4, QXBR, QXC9, QXS2, QXU, QX2, QX26, QX4, QX7, RX4, SG24, SMA7, SMW2, SM12, SM14, SSS2, SSS4, SWX2, SWX4, SXS4, SX4, SX7, TX, TXBR, TX2, TX26, TX4, UXU, VED1, VED6, VEE1, VEX, VEX7, VMS4, VPM4, VPR4, VXBR, VXU, VX4, VX7, WKD6, WKT2, WKT4, WKT6, WME2	
	34150-ZH7-013		1	-	-	-	4572370 HX, LJC, LJC8, LX, PX, QX, RX, SJC1, SJC5, SMJ, SX, VMT, VSX, VSX1, VX	
			-	(1)	-	-	4572370	
			1	-	-	-	4572371 HX, LJC, LJC8, LX, PX, QX, RX, SJC1, SJC5, SMJ, SX, VMT, VSX, VSX1, VX	
			-	(1)	-	-	4572371	
10	35120-Z0D-V81	SWITCH ASSY., ENGINE STOP	1	-	-	-	ARL, HT24, KRS4, KRS5, KRS6, WMA4	
	36100-ZE1-015		1	-	-	1	AR, DS, HT2, KR, KRT, KRT6, LD, LH, LJ, LJS, LSJ, LTJ, LTK1, LTR, LTS, QA, QA2, QD, QDBR, QH, QH26, QJG2, QM, QT, RD, SAJ, SD, SD16, SH, SJ, SM11, SSK1, SSK3, STP, STS, VED, VET, WDA6, WD12, WJ, WJP, WM1	
	36100-ZH7-003		-	(1)	1	-	HTF2, HX, HXU, HX26, LJC, LJC8, LX, LXU, LX2, PX, PX2, QMX2, QX, QXBR, QXC9, QXS2, QXU, QX2, QX26, RX, SJC1, SJC5, SMJ, SMW2, SM12, SSS2, SX, TX, TXBR, TX2, TX26, UXU, VED1, VED6, VEE1, VMT, VSX, VSX1, VX, VXBR, VXU, WKD6, WKT2, WKT4, WKT6, WME2	
			1	-	-	-	4453886 SWX2	
			1	-	-	-	4462599 HX2	
	36100-ZH8-W41		1	-	-	-	DKR, HHQ4, KRA4, KRF4, KRT4, LHQ4, LSJ4, QHQ4, QMA4, QME4, RD4, RHC, RHQ4, SAJ4, SAR4, SD4, SE, SHQ4, WMA3, WME4, WMK	



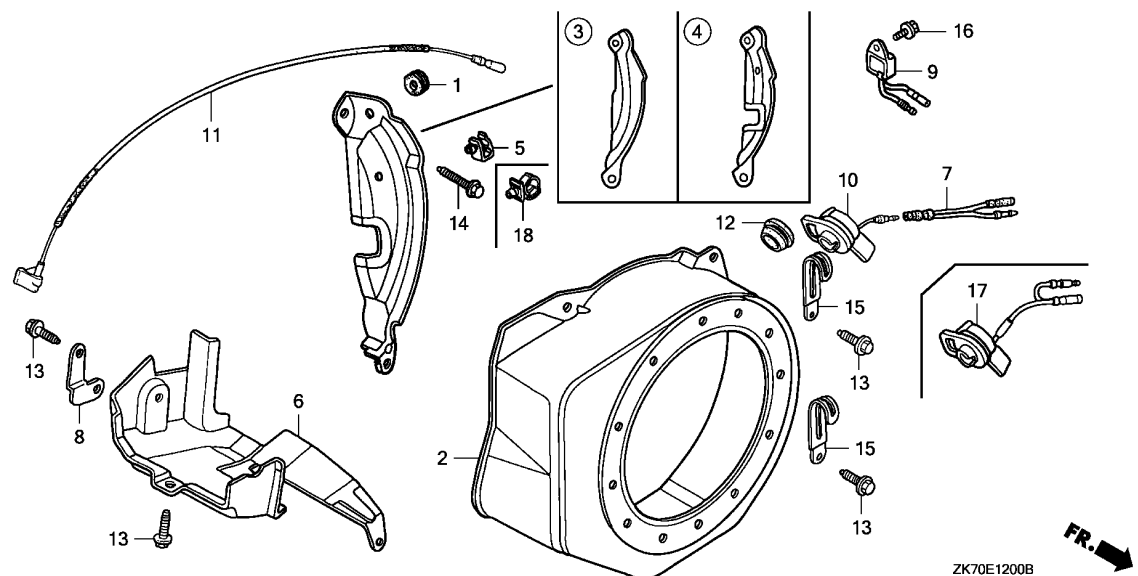

ZK70E1200B

Ref. No.	Part No.	Description	Reqd. QTY				Serial No.	Parts catalogue code
			(1)	(2)	(3)	(4)		
11	36101-ZE1-010	CORD, STOP SWITCH (370MM) ...	1	-	-	-	AR, ARL, DKR, DS, HHQ4, HTF2, HT2, HT24, HX, HXU, HX2, HX26, HX4, KR, KRA4, KRF4, KRS4, KRS5, KRS6, KRT, KRT4, KRT6, LAJ, LAJ4, LD, LH, LHQ4, LJ, LJC, LJC8, LJD2, LJS, LSJ, LSJ4, LTJ, LTK1, LTR, LTS, LX, LXU, LX2, LX4, PX, PX2, QA, QA2, QD, QH, QHQ4, QH26, QJG2, QLL, QM, QMA4, QMA8, QME4, QMX2, QT, QWA4, QX, QXC9, QXS2, QXU, QX2, QX26, QX4, QX7, RD, RD4, RHC, RHQ4, RX, RX4, SAJ, SAJ4, SAR4, SCJ, SD, SD16, SD4, SE, SG24, SH, SHQ4, SJ, SJC1, SJC5, SJD2, SKR, SMA7, SMJ, SMW2, SM11, SM12, SM14, SSK1, SSK3, SSS2, SSS4, STP, STS, SWX2, SWX4, SX, SXS4, SX4, SX7, TX, TX2, TX26, TX4, UXU, VED, VED1, VED6, VEE1, VEK, VET, VEX, VEX7, VMS4, VMT, VPM4, VPR4, VSX, VSX1, VX, VXU, VX4, VX7, WDA6, WD12, WJ, WJP, WKD6, WKT2, WKT4, WKT6, WMA3, WMA4, WME2, WME4, WMK, WM1	
	36101-ZK7-U50	CORD, STOP SWITCH (BOMBARDIER)	-	1	1	1	QB26	
	36101-ZK7-S90	CORD, STOP SWITCH	1	-	-	-	SYA	
12	81329-567-020	GROMMET, DRAIN HOLE	1	-	-	-	LAJ, LAJ4, LJD2, LTR, QB26, SCJ, SJD2, SKR, SYA, VEK, VPR4	
13	90013-883-000	BOLT, FLANGE, 6X12(CT200) ...	4	-	-	-	AR, ARL, DKR, KR, KRA4, KRF4, KRS4, KRS5, KRS6, KRT, KRT4, KRT6	
			6	-	-	-	DS, HHQ4, HTF2, HT2, HT24, HX, HXU, HX2, HX26, HX4, LAJ, LAJ4, LD, LH, LHQ4, LJ, LJC, LJC8, LJD2, LJS, LSJ, LSJ4, LTJ, LTK1, LTR, LTS, LX, LXU, LX2, LX4, PX, PX2, QA, QA2, QB26, QD, QH, QHQ4, QH26, QJG2, QLL, QM, QMA4, QMA8, QME4, QMX2, QT, QWA4, QX, QXC9, QXS2, QXU, QX2, QX26, QX4, QX7, RD, RD4, RHC, RHQ4, RX, RX4, SAJ, SAJ4, SAR4, SCJ, SD, SD16, SD4, SE, SG24, SH, SHQ4, SJ, SJC1, SJC5, SJD2, SKR, SMA7, SMJ, SMW2, SM11, SM12, SM14, SSK1, SSK3, SSS2, SSS4, STP, STS, SWX2, SWX4, SX, SXS4, SX4, SX7, SYA, TX, TX2, TX26, TX4, UXU, VED, VED1, VED6, VEE1, VEK, VET, VEX, VEX7, VMS4, VMT, VPM4, VPR4, VSX, VSX1, VX, VXU, VX4, VX7, WDA6, WD12, WJ, WJP, WKD6, WKT2, WKT4, WKT6, WMA3, WMA4, WME2, WME4, WMK, WM1	
14	90022-888-010	BOLT, FLANGE, 6X20(CT200) ...	-	6	6	6		
15	91406-657-671	CLIP, WIRE HARNESS	1	1	1	1	LJD2, SJD2	
			2	-	-	-		

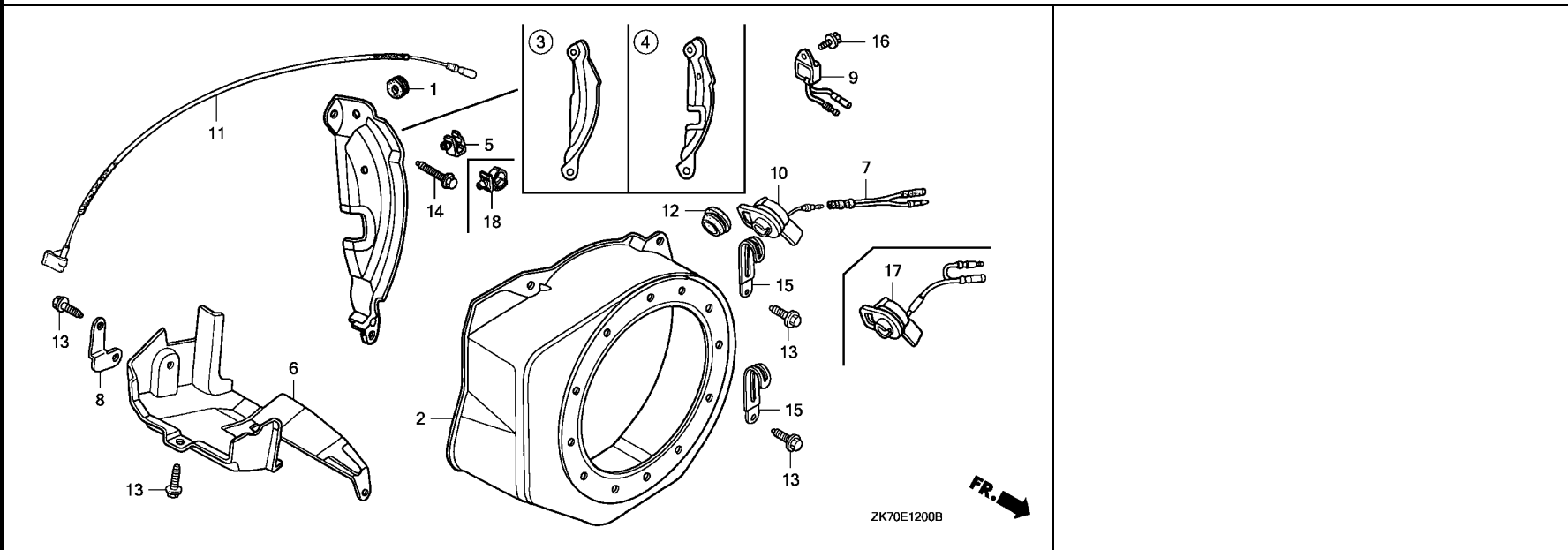

Ref. No.	Part No.	Description	Reqd. QTY				Serial No.	Parts catalogue code
			(1)	GX120K1 (2)	(3)	(4)		
16	95701-06008-00	BOLT, FLANGE, 6X8	1	-	-	1	-----	HTF2, HX, HXU, HX2, HX26, HX4, LJC, LJC8, LX, LXU, LX2, LX4, PX, PX2, QLL, QMA8, QMX2, QWA4, QX, QXBR, QXC9, QXS2, QXU, QX2, QX26, QX4, QX7, RX, RX4, SG24, SJC1, SJC5, SMA7, SMJ, SMW2, SM12, SM14, SSX2, SSX4, SWX2, SWX4, SXS4, SX4, SX7, TX, TXBR, TX2, TX26, TX4, UXU, VED1, VED6, VEE1, VEX, VEX7, VMS4, VMT, VPM4, VPR4, VSX, VSX1, VX, VXBR, VXU, VX4, VX7, WKD6, WKT2, WKT4, WKT6, WME2
17	36100-ZF6-P81	SWITCH ASSY., ENGINE STOP ...	1	-	(1)	-	-----	VPM4
	36100-ZH7-W41	1	-	-	-	4453887	SWX2
		1	-	-	-	4462600	HX2
18	90601-ZH7-013	CLIP, HARNESS	1	-	-	1	-----	HX4, LX4, QLL, QMA8, QWA4, QX4, QX7, RX4, SG24, SMA7, SM14, SSX4, SWX4, SXS4, SX4, SX7, TX4, VEX, VEX7, VMS4, VX4, VX7, WKT4
		1	-	-	1	-----	HTF2, HX, HXU, HX2, HX26, HX4, LJC, LJC8, LX, LXU, LX2, LX4, PX, PX2, QLL, QMA8, QMX2, QWA4, QX, QXBR, QXC9, QXS2, QXU, QX2, QX26, QX4, QX7, RX, RX4, SG24, SJC1, SJC5, SMA7, SMJ, SMW2, SM12, SM14, SSX2, SSX4, SWX2, SWX4, SXS4, SX4, SX7, TX, TXBR, TX2, TX26, TX4, UXU, VED1, VED6, VEE1, VEX, VEX7, VMS4, VMT, VPM4, VSX, VSX1, VX, VXBR, VXU, VX4, VX7, WKD6, WKT2, WKT4, WKT6, WME2
		-	(1)	-	-	-	-



E-14

CARBURETOR(1)

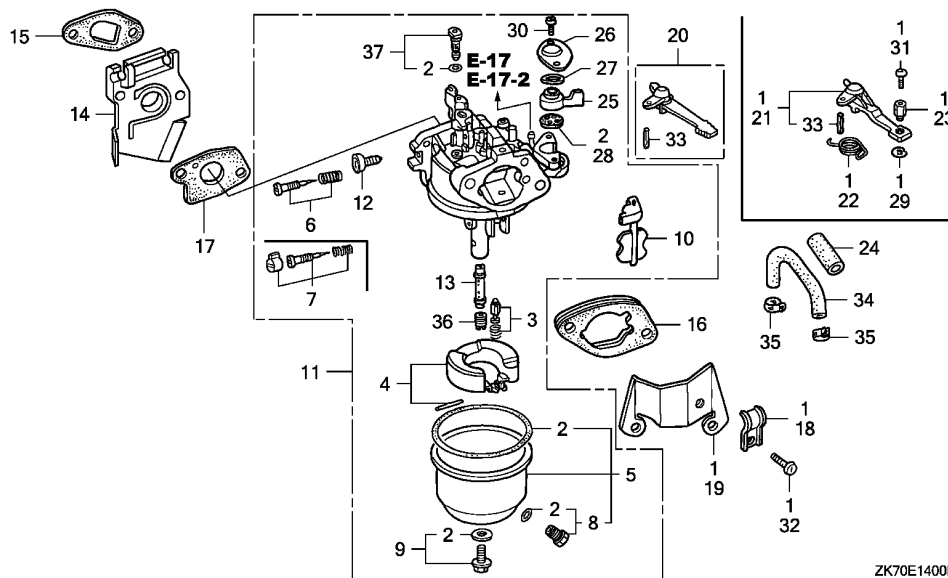
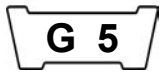

ZK70E1400B



Ref. No.	L.O.N.	(Relative ref. Number) Description	F.R.T.
1	8101C4	CHOKE KIT, REMOTE CONTROL	0.2
2	3111B1	GASKET SET, CARBURETOR (4)	0.3
3	3111E1	VALVE SET, FLOAT AND/OR FLOAT SET	0.3
5	3111A3	CHAMBER SET, FLOAT AND/OR GASKET, FLOAT CHAMBER (7)	0.2
6	3111D7	SCREW SET, PILOT	0.2
11	3111F3	CARBURETOR (15)	0.2
14	3111C0	INSULATOR, CARBURETOR AND/OR PACKING, INSULATOR	0.2
16	3111D9	SPACER, CARBURETOR	0.1
17	3111C8	PACKING, CARBURETOR	0.2
20	8101F9	LEVER, CARBURETOR CHOKE	0.2
22	3111M8	SPRING, CHOKE CONTROL STAY RETURN (25,26,27)	0.2
28	3101C5	PACKING, FUEL COCK	0.2
34	3101F6	TUBE, FUEL	0.2
36	3111C3	JET, MAIN	0.3

Ref. No.	Part No.	Description	Reqd. QTY				Serial No.	Parts catalogue code
			(1)	GX120K1 (2)	(3)	(4)		
1	06164-ZE1-000	CHOKE KIT, REMOTE CONTROL	-	(1)	-	-		
2	16010-ZB1-015	GASKET SET	1	-	-	-	AR,ARL,DKR,KR,KRA4,KRF4,KRS4,KRS5,KRS6,KRT,KRT4,KRT6	
	16010-ZE0-025		1	-	-	1	LD,LSJ4,QD,QDBR,QM,RD,RD4,SD,SD16,SD4,SE,WMA3,WMA4,WME4,WMK WM1	
3	16011-ZE0-005	VALVE SET, FLOAT	1	-	-	1	AR,ARL,DKR,KR,KRA4,KRF4,KRS4,KRS5,KRS6,KRT,KRT4,KRT6,LD,LSJ4 QD,QDBR,QM,RD,RD4,SD,SD16,SE,WMA3,WMA4,WME4,WMK,WM1	
4	16013-ZE0-005	FLOAT SET	1	-	-	1	AR,ARL,DKR,KR,KRA4,KRF4,KRS4,KRS5,KRS6,KRT,KRT4,KRT6,LD,LSJ4 QD,QDBR,QM,RD,RD4,SD,SD16,SE,WMA3,WMA4,WME4,WMK,WM1	
5	16015-ZE0-831	CHAMBER SET, FLOAT	1	-	-	1	LD,LSJ4,QD,QDBR,QM,RD,RD4,SD,SD16,SE,WMA3,WMA4,WME4,WMK,WM1	
	16015-ZE1-811		1	-	-	-	AR,ARL,DKR,KR,KRA4,KRF4,KRS4,KRS5,KRS6,KRT,KRT4,KRT6	
6	16016-ZE0-005	SCREW SET, PILOT (CARBURETOR NO.)	1	-	-	-	KRT6,QM	
			1	-	-	-	BE62A A KRA4	
7	16016-ZH7-W01	SCREW SET, PILOT (CARBURETOR NO.)	1	-	-	1	AR,ARL,DKR,KR,KRF4,KRS4,KRS5,KRS6,KRT,KRT4,LD,LSJ4,QD,QDBR,RD RD4,SD,SD16,SE,WMA3,WMA4,WME4,WMK,WM1	
8	16024-ZE1-811	SCREW SET, DRAIN	1	-	-	1	BE62C A KRA4	
			1	-	-	1	AR,ARL,DKR,KR,KRA4,KRF4,KRS4,KRS5,KRS6,KRT,KRT4,KRT6,LD,LSJ4 QD,QDBR,QM,RD,RD4,SD,SD16,SE,WMA3,WMA4,WME4,WMK,WM1	
9	16028-ZE0-005	SCREW SET	1	-	-	1	AR,ARL,DKR,KR,KRA4,KRF4,KRS4,KRS5,KRS6,KRT,KRT4,KRT6,LD,LSJ4 QD,QDBR,QM,RD,RD4,SD,SD16,SE,WMA3,WMA4,WME4,WMK,WM1	
			-	(1)	-	-		

Ref. No.	Part No.	Description	Reqd. QTY				Serial No.	Parts catalogue code
			(1)	(2)	(3)	(4)		
10	16044-ZE0-005	CHOKE SET	1	-	-	1	AR,ARL,DKR,KR,KRA4,KRF4,KRS4,KRS5,KRS6,KRT,KRT4,KRT6,LD,LSJ4,QD,QDBR,QM,RD,RD4,SD,SD16,SE,WMA3,WMA4,WME4,WMK,WM1	
			-	(1)	-	-		
11	16100-ZH7-W71	CARBURETOR ASSY. (BE61D B) ..	1	-	-	1	LD,LSJ4,QD,QDBR,RD,RD4,SD,SD16,SD4,WMA3,WMA4,WME4,WMK,WM1	
	16100-ZH7-W81	CARBURETOR ASSY. (BE61G A) ..	1	-	-	-	SE	
	16100-ZH7-812	CARBURETOR ASSY. (BE12B C) ..	1	-	-	-	QM	
			-	(1)	-	-		
	16100-ZK7-V01	CARBURETOR ASSY. (BE62A A) ..	1	-	-	-	KRT6	
			1	-	-	-	4503603 KRA4	
	16100-ZK7-U31	CARBURETOR ASSY. (BE62C A) ..	1	-	-	-	AR,ARL,DKR,KR,KRF4,KRS4,KRS5,KRS6,KRT,KRT4	
			1	-	-	-	4503604 KRA4	
12	16124-ZE0-005	SCREW, THROTTLE STOP	1	-	-	1	AR,ARL,DKR,KR,KRA4,KRF4,KRS4,KRS5,KRS6,KRT,KRT4,KRT6,LD,LSJ4,QD,QDBR,QM,RD,RD4,SD,SD16,SE,WMA3,WMA4,WME4,WMK,WM1	
			-	(1)	-	-		
13	16166-ZH7-A50	NOZZLE, MAIN	1	-	-	-	AR,ARL,DKR,KR,KRA4,KRF4,KRS4,KRS5,KRS6,KRT,KRT4,KRT6	
	16166-ZH7-W50	1	-	-	-	LD,LSJ4,QD,QM,RD,RD4,SD,SD16,SE,WMA3,WMA4,WME4,WMK,WM1	
			1	-	-	1	QDBR,WMA4	
			-	(1)	-	-		
14	16211-ZE0-000	INSULATOR, CARBURETOR	1	-	-	1	AR,ARL,DKR,KR,KRA4,KRF4,KRS4,KRS5,KRS6,KRT,KRT4,KRT6,LD,LSJ4,QD,QDBR,QM,RD,RD4,SD,SD16,SE,WMA3,WMA4,WME4,WMK,WM1	
			-	1	-	-		
15	16212-ZH7-800	PACKING, INSULATOR	1	-	-	1	AR,ARL,DKR,KR,KRA4,KRF4,KRS4,KRS5,KRS6,KRT,KRT4,KRT6,LD,LSJ4,QD,QDBR,QM,RD,RD4,SD,SD16,SE,WMA3,WMA4,WME4,WMK,WM1	
			-	(1)	-	-		
16	16220-ZE1-020	SPACER COMP., CARBURETOR	1	-	-	1	AR,ARL,DKR,KR,KRA4,KRF4,KRS4,KRS5,KRS6,KRT,KRT4,KRT6,LD,LSJ4,QD,QDBR,QM,RD,RD4,SD,SD16,SE,WMA3,WMA4,WME4,WMK,WM1	
			-	1	-	-		
17	16221-ZH8-801	PACKING, CARBURETOR	1	-	-	1	AR,ARL,DKR,KR,KRA4,KRF4,KRS4,KRS5,KRS6,KRT,KRT4,KRT6,LD,LSJ4,QD,QDBR,QM,RD,RD4,SD,SD16,SE,WMA3,WMA4,WME4,WMK,WM1	
			-	(1)	-	-		
18	16582-883-300	HOLDER, CONTROL CABLE	-	(1)	-	-		
19	16598-ZE1-000	STAY, CHOKE CONTROL	-	(1)	-	-		
20	16610-ZE1-000	LEVER COMP., CHOKE (STD.) ...	1	-	-	1	AR,ARL,DKR,KR,KRA4,KRF4,KRS4,KRS5,KRS6,KRT,KRT4,KRT6,LD,LSJ4,QD,QDBR,QM,RD,RD4,SD,SD16,SE,WMA3,WMA4,WME4,WMK,WM1	
			-	(1)	-	-		
21	16610-ZE1-810	LEVER COMP., CHOKE (REMOTE) ..	-	(1)	-	-		
22	16615-ZE1-010	SPRING, RETURN	-	(1)	-	-		
23	16617-890-010	HOLDER, CABLE	-	(1)	-	-		
24	16854-ZH8-000	RUBBER, SUPPORTER (107MM) ...	1	-	-	-	AR,ARL,DKR,KR,KRA4,KRF4,KRT,KRT4,KRT6	
25	16953-ZE1-812	LEVER, COCK	1	-	-	1	LD,LSJ4,QD,QDBR,QM,RD,RD4,SD,SD16,SE,WMA3,WMA4,WME4,WMK,WM1	
			-	(1)	-	-		
26	16954-ZE1-812	PLATE, LEVER SETTING	1	-	-	1	LD,LSJ4,QD,QDBR,QM,RD,RD4,SD,SD16,SE,WMA3,WMA4,WME4,WMK,WM1	
			-	(1)	-	-		
27	16956-ZE1-811	SPRING, COCK LEVER	1	-	-	1	LD,LSJ4,QD,QDBR,QM,RD,RD4,SD,SD16,SE,WMA3,WMA4,WME4,WMK,WM1	
			-	(1)	-	-		
28	16957-ZE1-812	PACKING, FUEL COCK	1	-	-	1	LD,LSJ4,QD,QDBR,QM,RD,RD4,SD,SD16,SE,WMA3,WMA4,WME4,WMK,WM1	
			-	(1)	-	-		
29	90605-230-000	CIRCLIP, 5MM	-	(1)	-	-		
30	93500-03006-1H	SCREW, PAN, 3X6	2	-	-	2	LD,LSJ4,QD,QDBR,QM,RD,RD4,SD,SD16,SE,WMA3,WMA4,WME4,WMK,WM1	
			-	(2)	-	-		
31	93500-04008-0A	SCREW, PAN, 4X8	-	(1)	-	-		
32	93500-05008-0A	SCREW, PAN, 5X8	-	(1)	-	-		



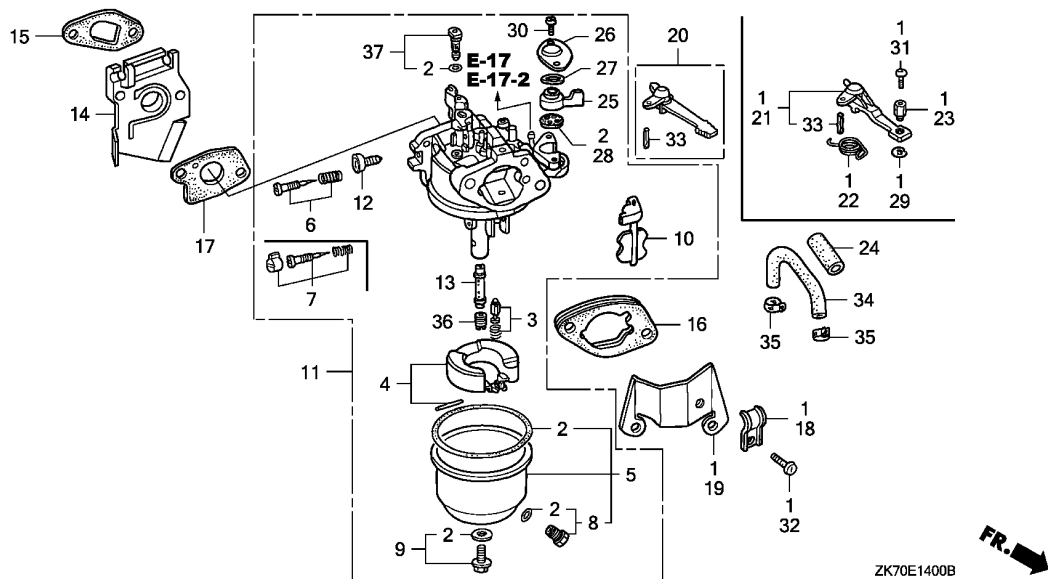

Ref. No.	Part No.	Description	Reqd. QTY				Serial No.	Parts catalogue code
			(1)	(2)	(3)	(4)		
33	94305-20122	PIN, SPRING, 2X12	1	-	-	1	AR, ARL, DKR, KR, KRA4, KRF4, KRS4, KRS5, KRS6, KRT, KRT4, KRT6, LD, LSJ4, QD, QDBR, QM, RD, RD4, SD, SD16, SE, WMA3, WMA4, WME4, WMK, WM1	
34	95001-45140-40	TUBE, FUEL, 4.5X140 (95001-45001-60M)	-	(1)	-	-		
	95001-45400-60	TUBE, FUEL, 4.5X400 (95001-45001-60M)	1	-	-	-	AR, ARL, DKR, KR, KRA4, KRF4, KRT, KRT4, KRT6	
35	95002-40800-08	CLAMP, TUBE (D8)	2	-	-	-	AR, ARL, DKR, KR, KRA4, KRF4, KRT, KRT4, KRT6	
36	99101-ZH8-0550	JET, MAIN, #55	(1)	-	-	-	QM, SE	
	99101-ZH8-0580	JET, MAIN, #58	(1)	-	-	(1)	AR, ARL, DKR, KR, KRA4, KRF4, KRS4, KRS5, KRS6, KRT, KRT4, KRT6, LD, LSJ4, QD, QDBR, QM, RD, RD4, SD, SD16, SE, WMA3, WMA4, WME4, WMK, WM1	
	99101-ZH8-0600	JET, MAIN, #60	1	-	-	-	QM, SE	
			(1)	-	-	(1)	AR, ARL, DKR, KR, KRA4, KRF4, KRS4, KRS5, KRS6, KRT, KRT4, KRT6, LD, LSJ4, QD, QDBR, RD, RD4, SD, SD16, WMA3, WMA4, WME4, WMK, WM1	
	99101-ZH8-0620	JET, MAIN, #62	1	-	-	1	AR, ARL, DKR, KR, KRA4, KRF4, KRS4, KRS5, KRS6, KRT, KRT4, KRT6, LD, LSJ4, QD, QDBR, RD, RD4, SD, SD16, WMA3, WMA4, WME4, WMK, WM1	
37	99204-ZE0-0350	JET SET, PILOT, #35	1	-	-	1	AR, ARL, DKR, KR, KRA4, KRF4, KRS4, KRS5, KRS6, KRT, KRT4, KRT6, LD, LSJ4, QD, QDBR, QM, RD, RD4, SD, SD16, SE, WMA3, WMA4, WME4, WMK, WM1	
			-	(1)	-	-		

E-14-1

CARBURETOR(2)

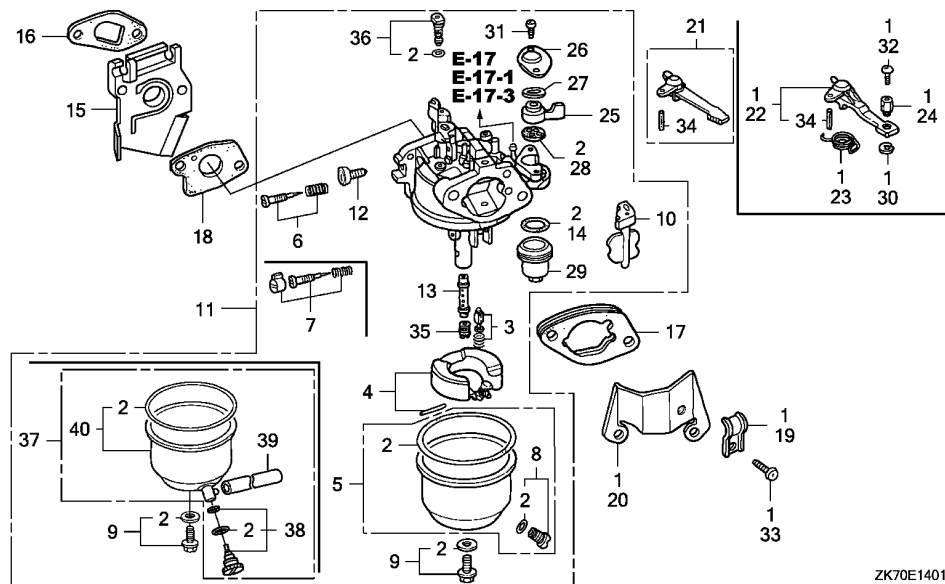
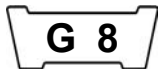

ZK70E1401C



Ref. No.	L.O.N.	(Relative ref. Number) Description	F.R.T.
1	8101C4	CHOKE KIT, REMOTE CONTROL	0.2
2	3111B1	GASKET SET, CARBURETOR	0.3
3	3111E1	VALVE SET, FLOAT AND/OR FLOAT SET	0.3
5	3111A3	CHAMBER SET, FLOAT AND/OR GASKET, FLOAT CHAMBER	0.2
6	3111D7	SCREW SET, PILOT	0.2
11	3111F3	CARBURETOR	0.2
14	3101L6	PACKING, FUEL STRAINER CUP ...	0.2
15	3111C0	INSULATOR, CARBURETOR AND/OR PACKING, INSULATOR	0.2
17	3111D9	SPACER, CARBURETOR	0.1
18	3111C8	PACKING, CARBURETOR	0.2
21	8101F9	LEVER, CARBURETOR CHOKE	0.2
23	3111M8	SPRING, CHOKE CONTROL STAY RETURN	0.2
28	3101C5	PACKING, FUEL COCK	0.2
35	3111C3	JET, MAIN	0.3

Ref. No.	Part No.	Description	Reqd. QTY				Serial No.	Parts catalogue code
			(1)	(2)	(3)	(4)		
1	06164-ZE1-000	CHOKE KIT, REMOTE CONTROL ...	-	(1)	-	-		
2	16010-ZB1-015	GASKET SET	1	-	-	-	VMT, VPM4, VPR4	
	16010-ZE1-812	1	-	-	1	DS, HHQ4, HTF2, HT2, HT24, HX, HXU, HX2, HX26, HX4, LAJ, LAJ4, LH, LHQ4, LJ, LJC, LJC8, LJD2, LJS, LSJ, LTJ, LTK1, LTR, LTS, LX, LXU, LX2, LX4, PX, PX2, QA, QA2, QB26, QH, QHQ4, QH26, QJG2, QLL, QMA4, QMA8, QME4, QMX2, QT, QWA4, QX, QXBR, QXC9, QXS2, QXU, QX2, QX26, QX4, QX7, RHC, RHQ4, RX, RX4, SAJ, SAJ4, SAR4, SCJ, SG24, SH, SHQ4, SJ, SJC1, SJC5, SJD2, SKR, SMA7, SMJ, SMW2, SM11, SM12, SM14, SSK1, SSK3, SSS2, SSS4, STP, STS, SWX2, SWX4, SX, SXS4, SX4, SX7, TX, TXBR, TX2, TX26, TX4, UXU, VED, VED1, VED6, VEE1, VET, VEX, VEX7, VMS4, VSX, VSX1, VX, VXBR, VXU, VX4, VX7, WDA6, WD12, WJ, WJP, WKD6, WKT2, WKT4, WKT6, WME2	
	16010-ZH7-A20	-	(1)	1	-	SYA, VEK	
3	16011-ZE0-005	VALVE SET, FLOAT	1	-	-	1	DS, HHQ4, HTF2, HT2, HT24, HX, HXU, HX2, HX26, HX4, LAJ, LAJ4, LH, LHQ4, LJ, LJC, LJC8, LJD2, LJS, LSJ, LTJ, LTK1, LTR, LTS, LX, LXU, LX2, LX4, PX, PX2, QA, QA2, QB26, QH, QHQ4, QH26, QJG2, QLL, QMA4, QMA8, QME4, QMX2, QT, QWA4, QX, QXBR, QXC9, QXS2, QXU, QX2, QX26, QX4, QX7, RHC, RHQ4, RX, RX4, SAJ, SAJ4, SAR4, SCJ, SG24, SH, SHQ4, SJ, SJC1, SJC5, SJD2, SKR, SMA7, SMJ, SMW2, SM11, SM12, SM14, SSK1, SSK3, SSS2, SSS4, STP, STS, SWX2, SWX4, SX, SXS4, SX4, SX7, SYA, TX, TXBR, TX2, TX26, TX4, UXU, VED, VED1, VED6, VEE1, VEK, VET, VEX, VEX7, VMS4, VMT, VPM4, VPR4, VSX, VSX1, VX, VXBR, VXU, VX4, VX7, WDA6, WD12, WJ, WJP, WKD6, WKT2, WKT4, WKT6, WME2	
		-	(1)	1	-		



E-14-1

CARBURETOR(2)

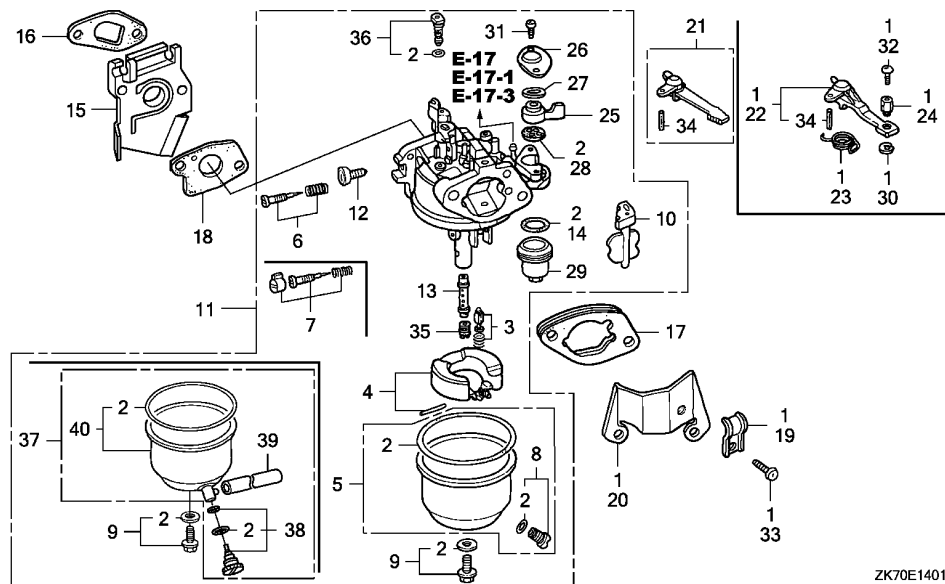
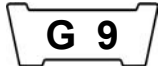

ZK70E1401C

Ref. No.	Part No.	Description	Reqd. QTY				Serial No.	Parts catalogue code
			(1)	(2)	(3)	(4)		
4	16013-ZE0-005	FLOAT SET	1	-	-	1	-----	DS,HHQ4,HTF2,HT2,HT24,HX,HXU,HX2,HX26,HX4,LAJ,LAJ4,LH,LHQ4,LJ,LJC,LJC8,LJD2,LJS,LSJ,LTJ,LTK1,LTR,LTS,LX,LXU,LX2,LX4,PX,PX2,QA,QA2,QB26,QH,QHQ4,QH26,QJG2,QLL,QMA4,QMA8,QME4,QMX2,QT,QWA4,QX,QXBR,QXC9,QXS2,QXU,QX2,QX26,QX4,QX7,RHC,RHQ4,RX,RX4,SAJ,SAJ4,SAR4,SCJ,SG24,SH,SHQ4,SJ,SJC1,SJC5,SJD2,SKR,SMAT7,SMJ,SMW2,SM11,SM12,SM14,SSK1,SSK3,SSX2,SSX4,STP,STS,SWX2,SWX4,SX,SXS4,SX4,SX7,SYA,TX,TXBR,TX2,TX26,TX4,UXU,VED,VED1,VED6,VEE1,VEK,VET,VEX,VEX7,VMS4,VMT,VPM4,VPR4,VSX,VSX1,VX,VXBR,VXU,VX4,VX7,WDA6,WD12,WJ,WJP,WKD6,WKT2,WKT4,WKT6,WME2
5	16015-ZE0-831	CHAMBER SET, FLOAT	1	(1)	1	1	-----	DS,HHQ4,HTF2,HT2,HT24,HX,HXU,HX2,HX26,HX4,LAJ,LAJ4,LH,LHQ4,LJ,LJC,LJC8,LJD2,LJS,LSJ,LTJ,LTK1,LTR,LTS,LX,LXU,LX2,LX4,PX,PX2,QA,QA2,QB26,QH,QHQ4,QH26,QJG2,QLL,QMA4,QMA8,QME4,QMX2,QT,QWA4,QX,QXBR,QXC9,QXS2,QXU,QX2,QX26,QX4,QX7,RHC,RHQ4,RX,RX4,SAJ,SAJ4,SAR4,SCJ,SG24,SH,SHQ4,SJ,SJC1,SJC5,SJD2,SKR,SMAT7,SMJ,SMW2,SM11,SM12,SM14,SSK1,SSK3,SSX2,SSX4,STP,STS,SWX2,SWX4,SX,SXS4,SX4,SX7,SYA,TX,TXBR,TX2,TX26,TX4,UXU,VED,VED1,VED6,VEE1,VET,VEX,VEX7,VMS4,VMT,VPM4,VPR4,VSX,VSX1,VX,VXBR,VXU,VX4,VX7,WDA6,WD12,WJ,WJP,WKD6,WKT2,WKT4,WKT6,WME2
	16015-ZE1-811	(CARBURETOR NO.)	-	(1)	-	-	-----	SIH,WIH
		(CARBURETOR NO.)	-	-	1	-	-----	BE12A B SIH,WIH
6	16016-ZE0-005	SCREW SET, PILOT	1	-	-	-	-----	LJC,LJC8,LTK1,QA,QB26,QT,STP,STS,VEK,VMT,VPR4,VSX,VSX1
		(CARBURETOR NO.)	1	-	-	-	-----	BE12A C QLL,RHC
		“ “	1	-	-	-	-----	BE60L A QME4
			-	(1)	1	-	-----	

E-14-1

CARBURETOR(2)

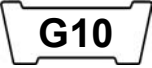

Ref. No.	Part No.	Description	Reqd. QTY				Serial No.	Parts catalogue code
			(1)	(2)	(3)	(4)		
7	16016-ZH7-W01	SCREW SET, PILOT	1	-	-	1	-----	DS,HHQ4,HTF2,HT2,HT24,HX,HXU,HX2,HX26,HX4,LAJ,LAJ4,LH,LHQ4,LJ,LJD2,LJS,LSJ,LTJ,LTR,LTS,LX,LXU,LX2,LX4,PX,PX2,QA2,QH,QHQ4,QH26,QJG2,QMA4,QMA8,QMX2,QWA4,QX,QXBR,QXC9,QXS2,QXU,QX2,QX26,QX4,QX7,RHQ4,RX,RX4,SAJ,SAJ4,SAR4,SCJ,SG24,SH,SHQ4,SJ,SJC1,SJC5,SJD2,SKR,SMA7,SMJ,SMW2,SM11,SM12,SM14,SSK1,SSK3,SSX2,SSX4,SWX2,SWX4, SX, SXS4, SX4, SX7, SYA, TX, TXBR, TX2, TX26, TX4, UXU, VED, VED1, VED6, VEE1, VET, VEX, VEX7, VMS4, VPM4, VX, VXBR, VXU, VX4, VX7, WDA6, WD12, WJ, WJP, WKD6, WKT2, WKT4, WKT6, WME2
		(CARBURETOR NO.)	1	-	-	-	-----	QLL,RHC
			1	-	-	-	-----	BE60B B
			1	-	-	-	-----	BE60C B
8	16024-ZE1-811	SCREW SET, DRAIN	1	-	-	1	-----	DS,HHQ4,HTF2,HT2,HT24,HX,HXU,HX2,HX26,HX4,LAJ,LAJ4,LH,LHQ4,LJ,LJC,LJC8,LJD2,LJS,LSJ,LTJ,LTK1,LTR,LTS,LX,LXU,LX2,LX4,PX,PX2,QA,QA2,QB26,QH,QHQ4,QH26,QJG2,QLL,QMA4,QMA8,QME4,QMX2,QT,QWA4,QX,QXBR,QXC9,QXS2,QXU,QX2,QX26,QX4,QX7,RHC,RHQ4,RX,RX4,SAJ,SAJ4,SAR4,SCJ,SG24,SH,SHQ4,SJ,SJC1,SJC5,SJD2,SKR,SMA7,SMJ,SMW2,SM11,SM12,SM14,SSK1,SSK3,SSX2,SSX4,STP,STS,SWX2,SWX4, SX, SXS4, SX4, SX7, TX, TXBR, TX2, TX26, TX4, UXU, VED, VED1, VED6, VEE1, VET, VEX, VEX7, VMS4, VMT, VPM4, VPR4, VSX, VSX1, VX, VXBR, VXU, VX4, VX7, WDA6, WD12, WJ, WJP, WKD6, WKT2, WKT4, WKT6, WME2
9	16028-ZE0-005	SCREW SET	-	(1)	1	-	-----	DS,HHQ4,HTF2,HT2,HT24,HX,HXU,HX2,HX26,HX4,LAJ,LAJ4,LH,LHQ4,LJ,LJC,LJC8,LJD2,LJS,LSJ,LTJ,LTK1,LTR,LTS,LX,LXU,LX2,LX4,PX,PX2,QA,QA2,QB26,QH,QHQ4,QH26,QJG2,QLL,QMA4,QMA8,QME4,QMX2,QT,QWA4,QX,QXBR,QXC9,QXS2,QXU,QX2,QX26,QX4,QX7,RHC,RHQ4,RX,RX4,SAJ,SAJ4,SAR4,SCJ,SG24,SH,SHQ4,SJ,SJC1,SJC5,SJD2,SKR,SMA7,SMJ,SMW2,SM11,SM12,SM14,SSK1,SSK3,SSX2,SSX4,STP,STS,SWX2,SWX4, SX, SXS4, SX4, SX7, TX, TXBR, TX2, TX26, TX4, UXU, VED, VED1, VED6, VEE1, VET, VEX, VEX7, VMS4, VMT, VPM4, VPR4, VSX, VSX1, VX, VXBR, VXU, VX4, VX7, WDA6, WD12, WJ, WJP, WKD6, WKT2, WKT4, WKT6, WME2
	16028-ZK7-S91	-	(1)	1	-	-----	SYA
10	16044-ZE0-005	CHOKE SET	1	-	1	1	-----	DS,HHQ4,HTF2,HT2,HT24,HX,HXU,HX2,HX26,HX4,LAJ,LAJ4,LH,LHQ4,LJ,LJC,LJC8,LJD2,LJS,LSJ,LTJ,LTK1,LTR,LTS,LX,LXU,LX2,LX4,PX,PX2,QA2,QB26,QH,QHQ4,QH26,QJG2,QLL,QMA4,QMA8,QME4,QMX2,QT,QWA4,QX,QXBR,QXC9,QXS2,QXU,QX2,QX26,QX4,QX7,RHC,RHQ4,RX,RX4,SAJ,SAJ4,SAR4,SCJ,SG24,SH,SHQ4,SJ,SJC1,SJC5,SJD2,SKR,SMA7,SMJ,SMW2,SM11,SM12,SM14,SSK1,SSK3,SSX2,SSX4,STP,SWX2,SWX4, SX, SXS4, SX4, SX7, SYA, TX, TXBR, TX2, TX26, TX4, UXU, VED, VED1, VED6, VEE1, VET, VEX, VEX7, VMS4, VMT, VPM4, VPR4, VSX, VSX1, VX, VXBR, VXU, VX4, VX7, WDA6, WD12, WJ, WJP, WKD6, WKT2, WKT4, WKT6, WME2
		(CARBURETOR NO.)	-	(1)	-	-	-----	SIH,WIH
			-	-	1	-	-----	BE12A B
11	16100-ZH7-T01	CARBURETOR ASSY. (BE12H B) ..	1	-	-	-	-----	VEK
	16100-ZH7-V21	CARBURETOR ASSY. (BE60F B) ..	1	-	-	-	-----	QXC9
	16100-ZH7-801	CARBURETOR ASSY. (BE13A B) ..	1	-	-	-	-----	STS
	16100-ZH7-820	CARBURETOR ASSY. (BE12A A) ..	-	(1)	-	-	-----	SIH,WIH
	16100-ZH7-821	CARBURETOR ASSY. (BE12A B) ..	-	-	1	-	-----	SIH,WIH
	16100-ZH7-822	CARBURETOR ASSY. (BE12A C) ..	1	-	1	-	-----	SIH,STP,VSX,VSX1,WIH
			1	-	-	-	-----	4419943 QLL,RHC
	16100-ZH7-831	CARBURETOR ASSY. (BE12C B) ..	-	(1)	-	-	-----	QA
			-	(1)	-	-	-----	
	16100-ZH7-841	CARBURETOR ASSY. (BE60L A) ..	1	-	-	-	-----	LJC,LJC8,LTK1,QT
			1	-	-	-	-----	4493918 QME4
			-	-	1	-	-----	
	16100-ZK7-U11	CARBURETOR ASSY. (BE28B A) ..	1	-	-	-	-----	VMT,VPR4



E-14-1

CARBURETOR(2)

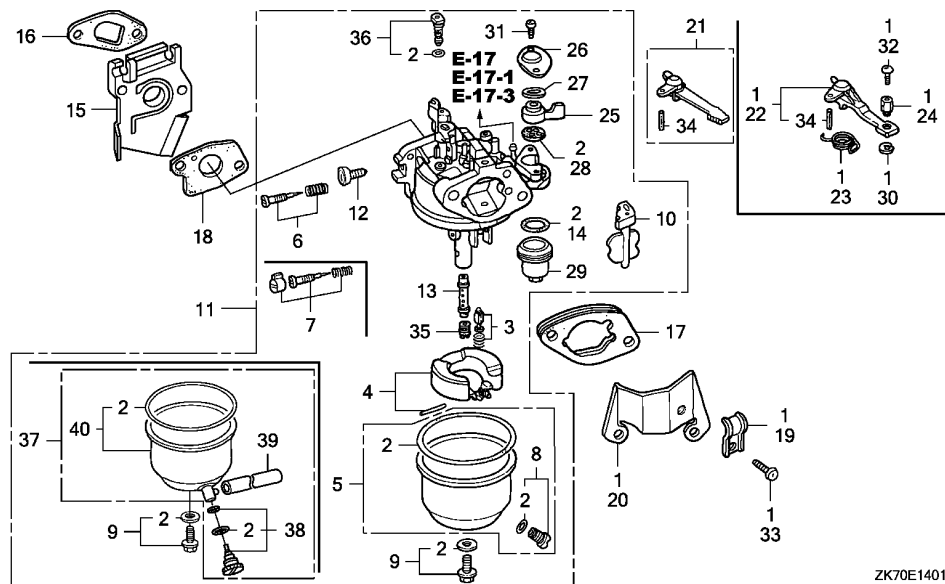

ZK70E1401C



Ref. No.	Part No.	Description	Reqd. QTY				Serial No.	Parts catalogue code
			(1)	GX120K1 (2)	(3)	(4)		
11)	16100-ZK7-U51	CARBURETOR ASSY. (BE60M A) ..	1	-	-	-	QB26	
	16100-ZH7-W51	CARBURETOR ASSY. (BE60B B) ..	1	-	-	1	HHQ4,HTF2,HT2,HT24,HX,HXU,HX2,HX26,HX4,LAJ4,LH,LHQ4,LJD2,LTJ LTS,LX,LXU,LX2,LX4,PX,PX2,QH,QHQ4,QH26,QJG2,QMA4,QMA8,QMX2 QWA4,QX,QXBR,QXS2,QXU,QX2,QX26,QX4,QX7,RHQ4,RX,RX4,SAJ4,SAR4 SG24,SH,SHQ4,SJD2,SMA7,SMJ,SMW2,SM11,SM12,SM14,SSK1,SSK3,SSX2 SSX4,SWX2,SWX4,SX,SXS4,SX4,SX7,TX,TXBR,TX2,TX26,TX4,UXU,VEE1 VEX,VEX7,VMS4,VX,VXBR,VXU,VX4,VX7,WDA6	
	16100-ZH7-W61	CARBURETOR ASSY. (BE60C B) ..	1	-	-	4419944	QLL,RHC DS,LAJ,LJ,LJS,LSJ,LTR,QA2,SAJ,SCJ,SJ,SJC1,SJC5,SKR,VED,VED1 VED6,VET,WD12,WJ,WJP,WKD6,WKT2,WKT4,WKT6,WME2	
	16100-ZK7-S61	CARBURETOR ASSY. (BE62E A) ..	1	-	-	4493919	QME4	
	16100-ZK7-S91	CARBURETOR ASSY. (BE60S A) ..	1	-	-	-	VPM4	
	16100-ZK7-S92	CARBURETOR ASSY. (BE60S B) ..	1	-	-	4555326	SYA	
12	16124-ZE0-005	SCREW, THROTTLE STOP	1	-	-	4555327	SYA	
							DS,HHQ4,HTF2,HT2,HT24,HX,HXU,HX2,HX26,HX4,LAJ,LAJ4,LH,LHQ4,LJ LJC,LJC8,LJD2,LJS,LSJ,LTJ,LTK1,LTR,LTS,LX,LXU,LX2,LX4,PX,PX2 QA,QA2,QB26,QH,QHQ4,QH26,QJG2,QLL,QMA4,QMA8,QME4,QMX2,QT,QWA4 QX,QXBR,QXC9,QXS2,QXU,QX2,QX26,QX4,QX7,RHC,RHQ4,RX,RX4,SAJ SAJ4,SAR4,SCJ,SG24,SH,SHQ4,SJ,SJC1,SJC5,SJD2,SKR,SMA7,SMJ,SMW2 SM11,SM12,SM14,SSK1,SSK3,SSX2,SSX4,STP,STS,SWX2,SWX4,SX,SXS4 SX4,SX7,SYA,TX,TXBR,TX2,TX26,TX4,UXU,VED,VED1,VED6,VEE1,VEK VET,VEX,VEX7,VMS4,VMT,VPM4,VPR4,VSX,VSX1,VX,VXBR,VXU,VX4,VX7 WDA6,WD12,WJ,WJP,WKD6,WKT2,WKT4,WKT6,WME2	
13	16166-ZH7-V20	NOZZLE, MAIN	1	(1)	1	-	QXC9	

E-14-1

CARBURETOR(2)



Ref. No.	Part No.	Description	Reqd. QTY				Serial No.	Parts catalogue code
			(1)	GX120K1 (2)	(3)	(4)		
13)	16166-ZH7-W50	NOZZLE, MAIN	1	-	1	1	-----	DS,HHQ4,HTF2,HT2,HT24,HX,HXU,HX2,HX26,HX4,LAJ,LAJ4,LH,LHQ4,LJ LJC,LJC8,LJD2,LJS,LSJ,LTJ,LTK1,LTR,LTS,LX,LXU,LX2,LX4,PX,PX2 QA2,QB26,QH,QHQ4,QH26,QJG2,QLL,QMA4,QMA8,QME4,QMX2,QT,QWA4,QX QXBR,QXS2,QXU,QX2,QX26,QX4,QX7,RHC,RHQ4,RX,RX4,SAJ,SAJ4,SAR4 SCJ,SG24,SH,SHQ4,SJ,SJC1,SJC5,SJD2,SKR,SMA7,SMJ,SMW2,SM11,SM12 SM14,SSK1,SSK3,SSX2,SSX4,STP,SWX2,SWX4,SX,SXS4,SX4,SX7,TX,TXBR TX2,TX26,UXU,VED,VED1,VED6,VEE1,VET,VEX,VEX7,VMS4,VMT,VPM4 VPR4,VSX,VSX1,VX,VXBR,VXU,VX4,VX7,WDA6,WD12,WIS,WJ,WJP,WKD6 WKT2,WKT4,WKT6,WME2
		(CARBURETOR NO.)	-	(1)	-	-	-----	SIH,WIH
	16166-ZH7-800	1	-	-	-	-----	STP
	16166-ZH7-820	1	-	-	-	-----	QA,VEK
		(CARBURETOR NO.)	-	(1)	-	-	-----	BE12A A SIH,WIH
	16166-ZK7-S91	1	-	-	-	-----	SYA
14	16173-001-004	PACKING, FUEL STRAINER CUP ..	1	-	-	1	-----	DS,HHQ4,HTF2,HT2,HT24,HX,HXU,HX2,HX26,HX4,LAJ,LAJ4,LH,LHQ4,LJ LJC,LJC8,LJD2,LJS,LSJ,LTJ,LTK1,LTR,LTS,LX,LXU,LX2,LX4,PX,PX2 QA,QA2,QB26,QH,QHQ4,QH26,QJG2,QLL,QMA4,QMA8,QME4,QMX2,QT,QWA4 QX,QXBR,QXC9,QXS2,QXU,QX2,QX26,QX4,QX7,RHC,RHQ4,RX,RX4,SAJ SAJ4,SAR4,SCJ,SG24,SH,SHQ4,SJ,SJC1,SJC5,SJD2,SKR,SMA7,SMJ,SMW2 SM11,SM12,SM14,SSK1,SSK3,SSX2,SSX4,STP,STS,SWX2,SWX4,SX,SXS4 SX4,SX7,SYA,TX,TXBR,TX2,TX26,UXU,VED,VED1,VED6,VEE1,VEK VET,VEX,VEX7,VMS4,VMT,VPM4,VPR4,VSX,VSX1,VX,VXBR,VXU,VX4,VX7,WDA6,WD12,WJ WJP,WKD6,WKT2,WKT4,WKT6,WME2
15	16211-ZE0-000	INSULATOR, CARBURETOR	1	(1)	1	-	-----	DS,HHQ4,HTF2,HT2,HT24,HX,HXU,HX2,HX26,HX4,LAJ,LAJ4,LH,LHQ4,LJ LJC,LJC8,LJD2,LJS,LSJ,LTJ,LTK1,LTR,LTS,LX,LXU,LX2,LX4,PX,PX2 QA,QA2,QB26,QH,QHQ4,QH26,QJG2,QLL,QMA4,QMA8,QME4,QMX2,QT,QWA4 QX,QXBR,QXC9,QXS2,QXU,QX2,QX26,QX4,QX7,RHC,RHQ4,RX,RX4,SAJ SAJ4,SAR4,SCJ,SG24,SH,SHQ4,SJ,SJC1,SJC5,SJD2,SKR,SMA7,SMJ,SMW2 SM11,SM12,SM14,SSK1,SSK3,SSX2,SSX4,STP,STS,SWX2,SWX4,SX,SXS4 SX4,SX7,SYA,TX,TXBR,TX2,TX26,UXU,VED,VED1,VED6,VEE1,VEK VET,VEX,VEX7,VMS4,VMT,VPM4,VPR4,VSX,VSX1,VX,VXBR,VXU,VX4,VX7 WDA6,WD12,WJ,WJP,WKD6,WKT2,WKT4,WKT6,WME2
16	16212-ZH7-800	PACKING, INSULATOR	1	-	-	1	-----	DS,HHQ4,HTF2,HT2,HT24,HX,HXU,HX2,HX26,HX4,LAJ,LAJ4,LH,LHQ4,LJ LJC,LJC8,LJD2,LJS,LSJ,LTJ,LTK1,LTR,LTS,LX,LXU,LX2,LX4,PX,PX2 QA,QA2,QB26,QH,QHQ4,QH26,QJG2,QLL,QMA4,QMA8,QME4,QMX2,QT,QWA4 QX,QXBR,QXC9,QXS2,QXU,QX2,QX26,QX4,QX7,RHC,RHQ4,RX,RX4,SAJ SAJ4,SAR4,SCJ,SG24,SH,SHQ4,SJ,SJC1,SJC5,SJD2,SKR,SMA7,SMJ,SMW2 SM11,SM12,SM14,SSK1,SSK3,SSX2,SSX4,STP,STS,SWX2,SWX4,SX,SXS4 SX4,SX7,SYA,TX,TXBR,TX2,TX26,UXU,VED,VED1,VED6,VEE1,VEK VET,VEX,VEX7,VMS4,VMT,VPM4,VPR4,VSX,VSX1,VX,VXBR,VXU,VX4,VX7 WDA6,WD12,WJ,WJP,WKD6,WKT2,WKT4,WKT6,WME2
17	16220-ZE1-004	SPACER COMP., CARBURETOR	-	(1)	1	-	-----	



E-14-1

CARBURETOR(2)

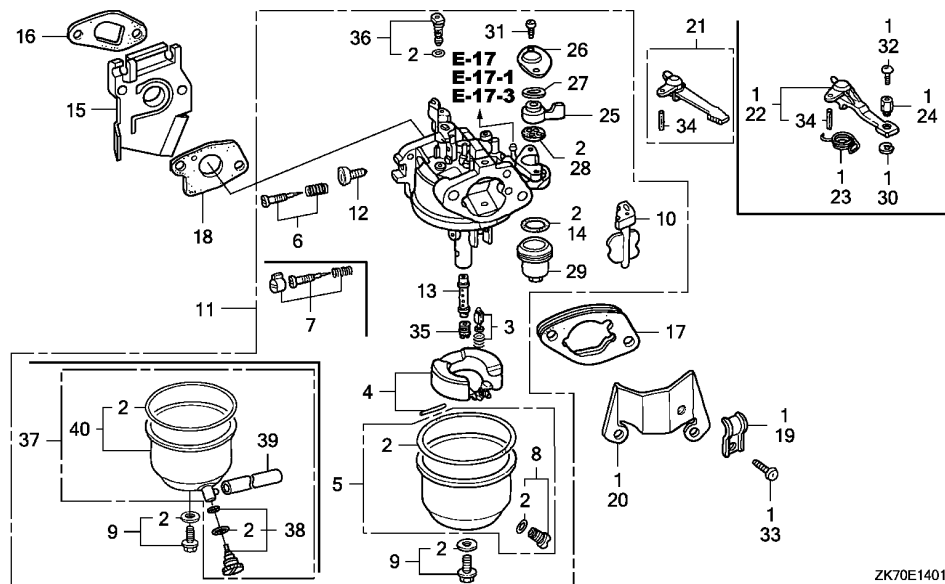

ZK70E1401C



Ref. No.	Part No.	Description	Reqd. QTY				Serial No.	Parts catalogue code
			(1)	(2)	(3)	(4)		
17)	16220-ZE1-020	SPACER COMP., CARBURETOR	1	-	-	1	-----	DS,HHQ4,HTF2,HT2,HT24,HX,HXU,HX2,HX26,HX4,LAJ,LAJ4,LH,LHQ4,LJ,LJC,LJC8,LJD2,LJS,LSJ,LTJ,LTK1,LTR,LTS,LX,LXU,LX2,LX4,PX,PX2,QA,QA2,QB26,QH,QHQ4,QH26,QJG2,QLL,QMA4,QMA8,QME4,QMX2,QT,QWA4,QX,QXBR,QXC9,QXS2,QXU,QX2,QX26,QX4,QX7,RHC,RHQ4,RX,RX4,SAJ,SAJ4,SAR4,SCJ,SG24,SH,SHQ4,SJ,SJC1,SJC5,SJD2,SKR,SMAT7,SMJ,SMW2,SM11,SM12,SM14,SSK1,SSK3,SSX2,SSX4,STP,STS,SWX2,SWX4,SX,SXS4,SX4,SX7,SYA,TX,TXBR,TX2,TX26,TX4,UXU,VED,VED1,VED6,VEE1,VEK,VET,VEX,VEX7,VMS4,VSX,VSX1,VX,VXBR,VXU,VX4,VX7,WDA6,WD12,WJ,WJP,WKD6,WKT2,WKT4,WKT6,WME2
18	16221-ZH8-800 16221-ZH8-801	PACKING, CARBURETOR	-	1	-	-	----- 2533057	SIH,WIH DS,HHQ4,HTF2,HT2,HT24,HX,HXU,HX2,HX26,HX4,LAJ,LAJ4,LH,LHQ4,LJ,LJC,LJC8,LJD2,LJS,LSJ,LTJ,LTK1,LTR,LTS,LX,LXU,LX2,LX4,PX,PX2,QA,QA2,QB26,QH,QHQ4,QH26,QJG2,QLL,QMA4,QMA8,QME4,QMX2,QT,QWA4,QX,QXBR,QXC9,QXS2,QXU,QX2,QX26,QX4,QX7,RHC,RHQ4,RX,RX4,SAJ,SAJ4,SAR4,SCJ,SG24,SH,SHQ4,SJ,SJC1,SJC5,SJD2,SKR,SMAT7,SMJ,SMW2,SM11,SM12,SM14,SSK1,SSK3,SSX2,SSX4,STP,STS,SWX2,SWX4,SX,SXS4,SX4,SX7,SYA,TX,TXBR,TX2,TX26,TX4,UXU,VED,VED1,VED6,VEE1,VEK,VET,VEX,VEX7,VMS4,VMT,VPM4,VPR4,VSX,VSX1,VX,VXBR,VXU,VX4,VX7,WDA6,WD12,WIS,WJ,WJP,WKD6,WKT2,WKT4,WKT6,WME2
19	16582-883-300	HOLDER, CONTROL CABLE	1	-	-	-	----- 2533058	SIH,WIH QB26
20	16598-ZE1-000	STAY, CHOKE CONTROL	1	-	-	-	-----	QB26,SYA
21	16610-ZB2-000	LEVER COMP., CHOKE	1	-	-	-	-----	VMT,VPM4,VPR4

E-14-1

CARBURETOR(2)



Ref. No.	Part No.	Description	Reqd. QTY				Serial No.	Parts catalogue code
			(1)	(2)	(3)	(4)		
21)	16610-ZE1-000	LEVER COMP., CHOKE (STD.) ...	1	-	-	1	-----	DS,HHQ4,HTF2,HT2,HT24,HX,HXU,HX2,HX26,HX4,LAJ,LAJ4,LH,LHQ4,LJ LJC,LJC8,LJD2,LJS,LSJ,LTJ,LTK1,LTR,LTS,LX,LXU,LX2,LX4,PX,PX2 QA,QA2,QH,QHQ4,QH26,QJG2,QLL,QMA4,QMA8,QME4,QMX2,QT,QWA4,QX QXBR,QXC9,QXS2,QXU,QX2,QX26,QX4,QX7,RHC,RHQ4,RX,RX4,SAJ,SAJ4 SAR4,SCJ,SG24,SH,SHQ4,SJ,SJC1,SJC5,SJD2,SKR,SMA7,SMJ,SMW2,SM11 SM12,SM14,SSK1,SSK3,SSX2,SSX4,STP,STS,SWX2,SWX4,SX,SXS4,SX4 SX7,TX,TXBR,TX2,TX26,TX4,UXU,VED,VED1,VED6,VEE1,VEK,VET,VEX VEX7,VMS4,VSX,VSX1,VX,VXBR,VXU,VX4,VX7,WDA6,WD12,WJ,WJP,WKD6 WKT2,WKT4,WKT6,WME2
			-	(1)	1	-		
22	16610-ZE1-810	LEVER COMP., CHOKE (REMOTE) .	1	-	-	-	-----	QB26,SYA
23	16615-ZE1-010	SPRING, RETURN	-	(1)	-	-		
24	16617-890-010	HOLDER, CABLE	1	-	-	-	-----	QB26
			-	(1)	-	-		
25	16953-ZE1-812	LEVER, COCK	1	-	-	1	-----	DS,HHQ4,HTF2,HT2,HT24,HX,HXU,HX2,HX26,HX4,LAJ,LAJ4,LH,LHQ4,LJ LJC,LJC8,LJD2,LJS,LSJ,LTJ,LTK1,LTR,LTS,LX,LXU,LX2,LX4,PX,PX2 QA,QA2,QB26,QH,QHQ4,QH26,QJG2,QLL,QMA4,QMA8,QME4,QMX2,QT,QWA4 QX,QXBR,QXC9,QXS2,QXU,QX2,QX26,QX4,QX7,RHC,RHQ4,RX,RX4,SAJ SAJ4,SAR4,SCJ,SG24,SH,SHQ4,SJ,SJC1,SJC5,SJD2,SKR,SMA7,SMJ,SMW2 SM11,SM12,SM14,SSK1,SSK3,SSX2,SSX4,STP,STS,SWX2,SWX4,SX,SXS4 SX4,SX7,SYA,TX,TXBR,TX2,TX26,TX4,UXU,VED,VED1,VED6,VEE1,VEK VET,VEX,VEX7,VMS4,VSX,VSX1,VX,VXBR,VXU,VX4,VX7,WDA6,WD12,WJ WJP,WKD6,WKT2,WKT4,WKT6,WME2
			-	(1)	1	-		
26	16954-ZE1-812	PLATE, LEVER SETTING	1	-	-	1	-----	DS,HHQ4,HTF2,HT2,HT24,HX,HXU,HX2,HX26,HX4,LAJ,LAJ4,LH,LHQ4,LJ LJC,LJC8,LJD2,LJS,LSJ,LTJ,LTK1,LTR,LTS,LX,LXU,LX2,LX4,PX,PX2 QA,QA2,QB26,QH,QHQ4,QH26,QJG2,QLL,QMA4,QMA8,QME4,QMX2,QT,QWA4 QX,QXBR,QXC9,QXS2,QXU,QX2,QX26,QX4,QX7,RHC,RHQ4,RX,RX4,SAJ SAJ4,SAR4,SCJ,SG24,SH,SHQ4,SJ,SJC1,SJC5,SJD2,SKR,SMA7,SMJ,SMW2 SM11,SM12,SM14,SSK1,SSK3,SSX2,SSX4,STP,STS,SWX2,SWX4,SX,SXS4 SX4,SX7,SYA,TX,TXBR,TX2,TX26,TX4,UXU,VED,VED1,VED6,VEE1,VEK VET,VEX,VEX7,VMS4,VSX,VSX1,VX,VXBR,VXU,VX4,VX7,WDA6,WD12,WJ WJP,WKD6,WKT2,WKT4,WKT6,WME2
			-	(1)	1	-		
27	16956-ZE1-811	SPRING, COCK LEVER	1	-	-	1	-----	DS,HHQ4,HTF2,HT2,HT24,HX,HXU,HX2,HX26,HX4,LAJ,LAJ4,LH,LHQ4,LJ LJC,LJC8,LJD2,LJS,LSJ,LTJ,LTK1,LTR,LTS,LX,LXU,LX2,LX4,PX,PX2 QA,QA2,QB26,QH,QHQ4,QH26,QJG2,QLL,QMA4,QMA8,QME4,QMX2,QT,QWA4 QX,QXBR,QXC9,QXS2,QXU,QX2,QX26,QX4,QX7,RHC,RHQ4,RX,RX4,SAJ SAJ4,SAR4,SCJ,SG24,SH,SHQ4,SJ,SJC1,SJC5,SJD2,SKR,SMA7,SMJ,SMW2 SM11,SM12,SM14,SSK1,SSK3,SSX2,SSX4,STP,STS,SWX2,SWX4,SX,SXS4 SX4,SX7,SYA,TX,TXBR,TX2,TX26,TX4,UXU,VED,VED1,VED6,VEE1,VEK VET,VEX,VEX7,VMS4,VSX,VSX1,VX,VXBR,VXU,VX4,VX7,WDA6,WD12,WJ WJP,WKD6,WKT2,WKT4,WKT6,WME2
			-	(1)	1	-		
28	16957-ZE1-812	PACKING, FUEL COCK	1	-	-	1	-----	DS,HHQ4,HTF2,HT2,HT24,HX,HXU,HX2,HX26,HX4,LAJ,LAJ4,LH,LHQ4,LJ LJC,LJC8,LJD2,LJS,LSJ,LTJ,LTK1,LTR,LTS,LX,LXU,LX2,LX4,PX,PX2 QA,QA2,QB26,QH,QHQ4,QH26,QJG2,QLL,QMA4,QMA8,QME4,QMX2,QT,QWA4 QX,QXBR,QXC9,QXS2,QXU,QX2,QX26,QX4,QX7,RHC,RHQ4,RX,RX4,SAJ SAJ4,SAR4,SCJ,SG24,SH,SHQ4,SJ,SJC1,SJC5,SJD2,SKR,SMA7,SMJ,SMW2 SM11,SM12,SM14,SSK1,SSK3,SSX2,SSX4,STP,STS,SWX2,SWX4,SX,SXS4 SX4,SX7,SYA,TX,TXBR,TX2,TX26,TX4,UXU,VED,VED1,VED6,VEE1,VEK VET,VEX,VEX7,VMS4,VSX,VSX1,VX,VXBR,VXU,VX4,VX7,WDA6,WD12,WJ WJP,WKD6,WKT2,WKT4,WKT6,WME2
			-	(1)	1	-		



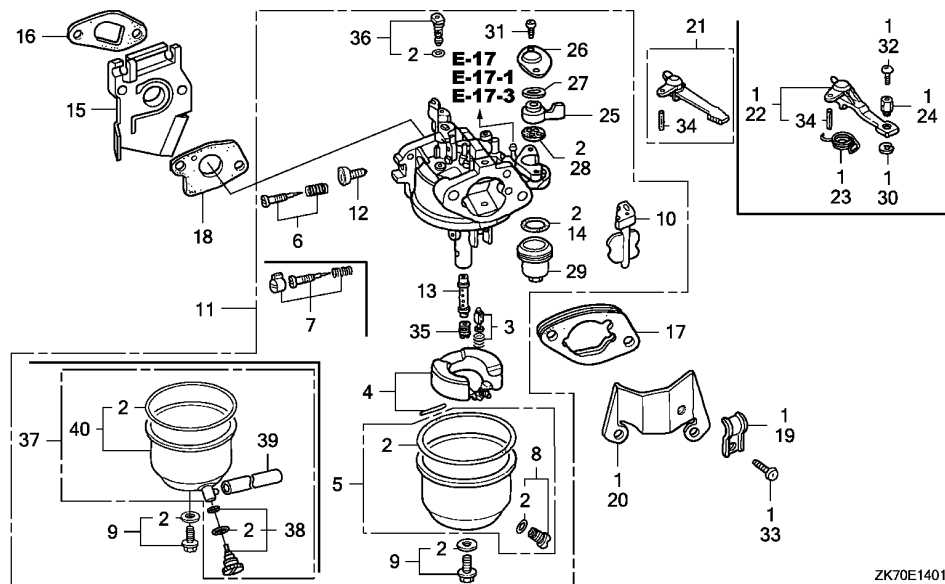

ZK70E1401C

Ref. No.	Part No.	Description	Reqd. QTY				Serial No.	Parts catalogue code
			(1)	(2)	(3)	(4)		
29	16967-ZE0-811	CUP, FUEL STRAINER	1	-	-	1	-----	DS,HHQ4,HTF2,HT2,HT24,HX,HXU,HX2,HX26,HX4,LAJ,LAJ4,LH,LHQ4,LJ,LJC,LJC8,LJD2,LJS,LSJ,LTJ,LTK1,LTR,LTS,LX,LXU,LX2,LX4,PX,PX2,QA,QA2,QB26,QH,QHQ4,QH26,QJG2,QLL,QMA4,QMA8,QME4,QMX2,QT,QWA4,QX,QXBR,QXC9,QXS2,QXU,QX2,QX26,QX4,QX7,RHC,RHQ4,RX,RX4,SAJ,SAJ4,SAR4,SCJ,SG24,SH,SHQ4,SJ,SJC1,SJC5,SJD2,SKR,SMA7,SMJ,SMW2,SM11,SM12,SM14,SSK1,SSK3,SSX2,SSX4,STP,STS,SWX2,SWX4,SX,SXS4,SX4,SX7,SYA,TX,TXBR,TX2,TX26,TX4,UXU,VED,VED1,VED6,VEE1,VEK,VET,VEX,VEX7,VMS4,VSX,VSX1,VX,VXBR,VXU,VX4,VX7,WDA6,WD12,WJ,WJP,WKD6,WKT2,WKT4,WKT6,WME2
30	90605-230-000	CIRCLIP, 5MM	1	(1)	1	-	-----	DS,LAJ,LAJ4,LJ,LJD2,LJS,LSJ,LTJ,LTK1,LTR,LTS,QB26,QJG2,QLL,QMA8,QME4,QMX2,QWA4,QXC9,SAJ,SCJ,SG24,SJ,SJC1,SJC5,SJD2,SKR,SMA7,SMJ,SMW2,SM11,SM12,SM14,STP,STS,VEE1,VET,WJ,WJP,WKD6,WKT2,WKT4,WKT6,WME2
31	93500-03006-1H	SCREW, PAN, 3X6	2	(1)	-	-	-----	DS,HHQ4,HTF2,HT2,HT24,HX,HXU,HX2,HX26,HX4,LAJ,LAJ4,LH,LHQ4,LJ,LJC,LJC8,LJD2,LJS,LSJ,LTJ,LTK1,LTR,LTS,LX,LXU,LX2,LX4,PX,PX2,QA,QA2,QB26,QH,QHQ4,QH26,QJG2,QLL,QMA4,QMA8,QME4,QMX2,QT,QWA4,QX,QXC9,QXS2,QXU,QX2,QX26,QX4,QX7,RHC,RHQ4,RX,RX4,SAJ,SAJ4,SAR4,SCJ,SG24,SH,SHQ4,SJ,SJC1,SJC5,SJD2,SKR,SMA7,SMJ,SMW2,SM11,SM12,SM14,SSK1,SSK3,SSX2,SSX4,STP,STS,SWX2,SWX4,SX,SXS4,SX4,SX7,SYA,TX,TX2,TX26,TX4,UXU,VED,VED1,VED6,VEE1,VEK,VET,VEX,VEX7,VMS4,VSX,VSX1,VX,VXU,VX4,VX7,WDA6,WD12,WJ,WJP,WKD6,WKT2,WKT4,WKT6,WME2
	93500-03008-1G	SCREW, PAN, 3X8 (CARBURETOR NO.)	-	(2)	-	-	-----	BE12A B SIH,WIH

E-14-1

CARBURETOR(2)

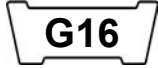

Ref. No.	Part No.	Description	Reqd. QTY				Serial No.	Parts catalogue code
			(1)	(2)	(3)	(4)		
31)	93500-03006-1H	SCREW, PAN, 3X6 (CARBURETOR NO.)	2	-	2	2	-----	QXBR, SAR4, TXBR, VXBR, WIS
32	93500-04008-0A	SCREW, PAN, 4X8	1	-	-	-	-----	BE12A C ----- SIH, WIH
33	93500-05008-0A	SCREW, PAN, 5X8	1	-	-	-	-----	QB26
34	94305-20122	PIN, SPRING, 2X12	1	-	-	1	-----	DS, HHQ4, HTF2, HT2, HT24, HX, HXU, HX2, HX26, HX4, LAJ, LAJ4, LH, LHQ4, LJ, LJC, LJC8, LJD2, LJS, LSJ, LTJ, LTK1, LTR, LTS, LX, LXU, LX2, LX4, PX, PX2, QA, QA2, QB26, QH, QHQ4, QH26, QJG2, QLL, QMA4, QMA8, QME4, QMX2, QT, QWA4, QX, QXBR, QXC9, QXS2, QXU, QX2, QX26, QX4, QX7, RHC, RHQ4, RX, RX4, SAJ, SAJ4, SAR4, SCJ, SG24, SH, SHQ4, SJ, SJC1, SJC5, SJD2, SKR, SMA7, SMJ, SMW2, SM11, SM12, SM14, SSK1, SSK3, SSX2, SSX4, STP, STS, SWX2, SWX4, SX, SXS4, SX4, SX7, SYA, TX, TXBR, TX2, TX26, TX4, UXU, VED, VED1, VED6, VEE1, VEK, VET, VEX, VEX7, VMS4, VMT, VPM4, VPR4, VSX, VSX1, VX, VXBR, VXU, VX4, VX7, WDA6, WD12, WJ, WJP, WKD6, WKT2, WKT4, WKT6, WME2
35	99101-ZF5-0550	JET, MAIN, #55 (CARBURETOR NO.)	-	(1)	1	-	-----	BE12A A SIH, WIH
	99101-ZF5-0580	JET, MAIN, #58 (CARBURETOR NO.)	-	-	(1)	-	-----	BE12A A SIH, WIH
	99101-ZF5-0600	JET, MAIN, #60 (CARBURETOR NO.)	-	-	1	-	-----	BE12A A SIH, WIH
	99101-ZH7-0600	(CARBURETOR NO.)	-	-	1	-	-----	BE12A B BE12A C SIH, WIH
	99101-ZH8-0550	JET, MAIN, #55	(1)	-	-	(1)	-----	HHQ4, HTF2, HT2, HT24, HX, HXU, HX2, HX26, HX4, LAJ4, LH, LHQ4, LJD2, LTS, LX, LXU, LX2, LX4, PX, PX2, QA, QB26, QH, QHQ4, QH26, QJG2, QLL, QMA4, QMA8, QMX2, QWA4, QX, QXBR, QXS2, QXU, QX2, QX26, QX4, QX7, RHC, RHQ4, RX, RX4, SAJ, SAJ4, SAR4, SG24, SH, SHQ4, SJD2, SMA7, SMJ, SMW2, SM11, SM12, SM14, SSK1, SSK3, SSX2, SSX4, STP, SWX2, SWX4, SX, SXS4, SX4, SX7, TX, TXBR, TX2, TX26, TX4, UXU, VEE1, VEK, VEX, VEX7, VMS4, VSX, VSX1, VX, VXBR, VXU, VX4, VX7, WDA6
	99101-ZH8-0580	JET, MAIN, #58	(1)	(1)	(1)	(1)	-----	DS, HHQ4, HTF2, HT2, HT24, HX, HXU, HX2, HX26, HX4, LAJ, LAJ4, LH, LHQ4, LJ, LJC, LJC8, LJD2, LJS, LSJ, LTJ, LTK1, LTR, LTS, LX, LXU, LX2, LX4, PX, PX2, QA, QA2, QB26, QH, QHQ4, QH26, QJG2, QLL, QMA4, QMA8, QME4, QMX2, QT, QWA4, QX, QXBR, QXC9, QXS2, QXU, QX2, QX26, QX4, QX7, RHC, RHQ4, RX, RX4, SAJ, SAJ4, SAR4, SCJ, SG24, SH, SHQ4, SJ, SJC1, SJC5, SJD2, SKR, SMA7, SMJ, SMW2, SM11, SM12, SM14, SSK1, SSK3, SSX2, SSX4, STP, STS, SWX2, SWX4, SX, SXS4, SX4, SX7, TX, TXBR, TX2, TX26, TX4, UXU, VED, VED1, VED6, VEE1, VEK, VET, VEX, VEX7, VMS4, VMT, VPM4, VPR4, VSX, VSX1, VX, VXBR, VXU, VX4, VX7, WDA6, WD12, WIS, WJ, WJP, WKD6, WKT2, WKT4, WKT6, WME2
	99101-ZH8-0600	(CARBURETOR NO.) JET, MAIN, #60	1	-	-	-	-----	BE12A B ----- SIH, WIH
	99101-ZH8-0620	(CARBURETOR NO.) JET, MAIN, #62	1	-	1	-	-----	HHQ4, HTF2, HT2, HT24, HX, HXU, HX2, HX26, HX4, LAJ4, LH, LHQ4, LJD2, LTJ, LTS, LX, LXU, LX2, LX4, PX, PX2, QA, QH, QHQ4, QH26, QJG2, QLL, QMA4, QMA8, QMX2, QWA4, QX, QXS2, QXU, QX2, QX26, QX4, QX7, RHC, RHQ4, RX, RX4, SAJ4, SAR4, SG24, SH, SHQ4, SJD2, SMA7, SMJ, SMW2, SM11, SM12, SM14, SSK1, SSK3, SSX2, SSX4, STP, SWX2, SWX4, SX, SXS4, SX4, SX7, TX, TX2, TX26, TX4, UXU, VEE1, VEK, VEX, VEX7, VMS4, VSX, VSX1, VX, VXU, VX4, VX7, WDA6
		(CARBURETOR NO.)	(1)	-	(1)	1	-----	DS, LAJ, LJ, LJC, LJC8, LJS, LSJ, LTK1, LTR, QA2, QME4, QT, QXBR, QXC9, SAJ, SCJ, SJ, SJC1, SJC5, SKR, STS, TXBR, VED, VED1, VED6, VET, VMT, VPM4, VPR4, VXBR, WD12, WIS, WJ, WJP, WKD6, WKT2, WKT4, WKT6, WME2
		(CARBURETOR NO.)	-	1	-	-	-----	BE12A B ----- SIH, WIH
		(CARBURETOR NO.)	-	-	(1)	-	-----	DS, LAJ, LJ, LJC, LJC8, LJS, LSJ, LTK1, LTR, QA2, QME4, QT, QXC9, SAJ, SCJ, SJ, SJC1, SJC5, SKR, STS, VED, VED1, VED6, VET, VMT, VPM4, VPR4, WD12, WIS, WJ, WJP, WKD6, WKT2, WKT4, WKT6, WME2
		(CARBURETOR NO.)	-	-	1	-	-----	BE60L A ----- SIH, WIH



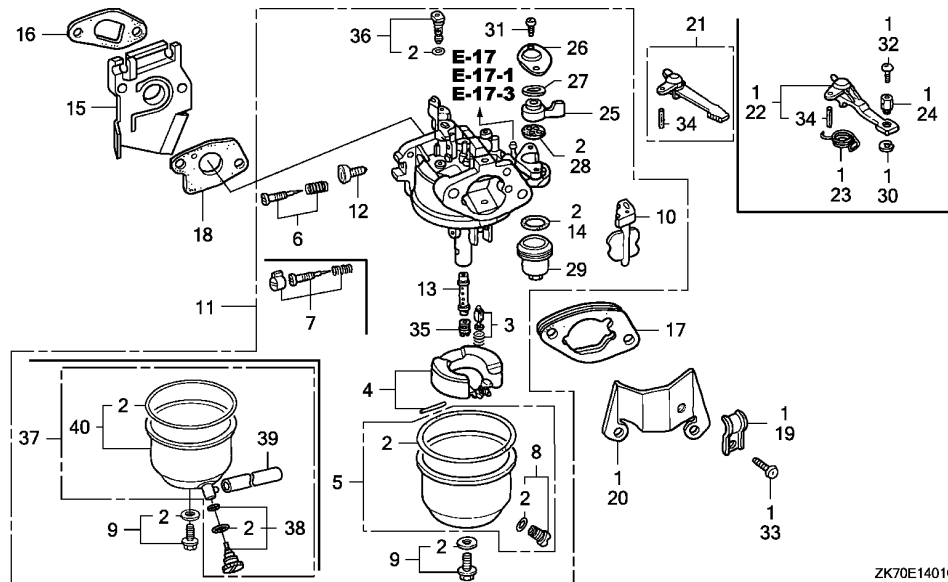

Ref. No.	Part No.	Description	Reqd. QTY				Serial No.	Parts catalogue code
			(1)	(2)	(3)	(4)		
35)	99101-ZH8-0680	JET, MAIN, #68	1	-	-	-	-----	QB26
	99101-ZK7-0580	JET, MAIN, #58	(1)	-	-	-	-----	SYA
	99101-ZK7-0600	JET, MAIN, #60	(1)	-	-	-	-----	SYA
	99101-ZK7-0620	JET, MAIN, #62	1	-	-	-	-----	SYA
36	99204-ZE0-0350	JET SET, PILOT, #35	1	-	-	1	-----	DS, HHQ4, HTF2, HT2, HT24, HX, HXU, HX2, HX26, HX4, LAJ, LAJ4, LH, LHQ4, LJ, LJC, LJC8, LJD2, LJS, LSJ, LTJ, LTK1, LTR, LTS, LX, LXU, LX2, LX4, PX, PX2, QA, QA2, QB26, QH, QHQ4, QH26, QJG2, QLL, QMA4, QMA8, QME4, QMX2, QT, QWA4, QX, QXBR, QXS2, QXU, QX2, QX26, QX4, QX7, RHC, RHQ4, RX, RX4, SAJ, SAJ4, SAR4, SCJ, SG24, SH, SHQ4, SJ, SJC1, SJC5, SJD2, SKR, SMA7, SMJ, SMW2, SM11, SM12, SM14, SSK1, SSK3, SSS2, SSS4, STP, STS, SWX2, SWX4, SX, SXS4, SX4, SX7, SYA, TX, TXBR, TX2, TX26, TX4, UXU, VED, VED1, VED6, VEE1, VEK, VET, VEX, VEX7, VMS4, VMT, VPM4, VPR4, VSX, VSX1, VX, VXBR, VXU, VX4, VX7, WDA6, WD12, WJ, WJP, WKD6, WKT2, WKT4, WKT6, WME2
	99204-ZE2-0380	JET SET, PILOT, #38	1	(1)	1	-	-----	QXC9
37	16015-ZK7-S91	CHAMBER SET, FLOAT	1	-	-	-	-----	SYA
38	16024-ZH7-A20	SCREW SET, DRAIN	1	-	-	-	-----	SYA, VEK
39	95003-10040-31	TUBE, VINYL, 5X8X400	1	-	-	-	-----	4512526 SYA
	95003-10024-31	TUBE, VINYL, 5X8X240	1	-	-	-	-----	4512527 SYA
40	16015-ZH7-A21	CHAMBER SET, FLOAT	1	-	-	-	-----	VEK

E-15

AIR CLEANER(1)

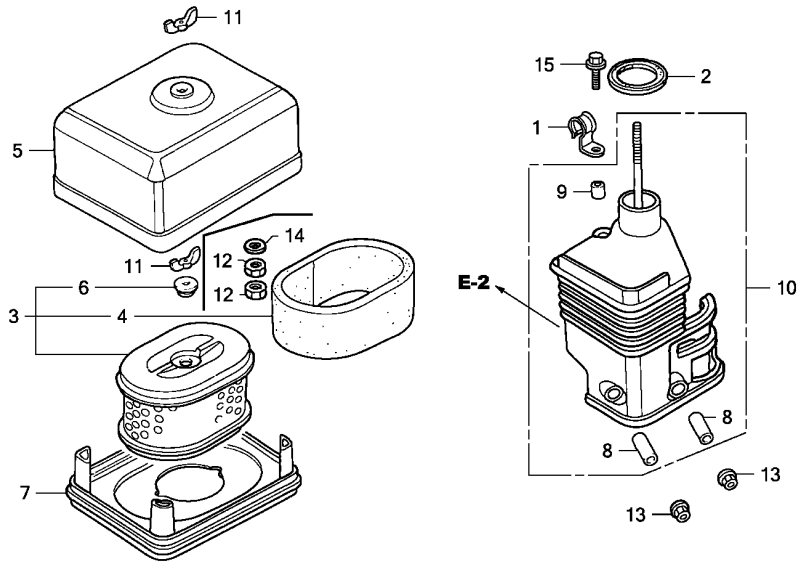

ZK70E1500A

Ref. No.	L.O.N.	(Relative ref. Number) Description	F.R.T.
2	3121E1	PACKING, ELBOW	0.1
3	3121B8	ELEMENT, AIR CLEANER	0.1
		.INCLUDES: Air cleaner- inspection	
4	3121C1	FILTER, OUTER	0.1
7	3121D6	NOSE, SILENCER	0.1
10	3121B4	ELBOW, AIR CLEANER	0.1

Ref. No.	Part No.	Description	Reqd. QTY				Serial No.	Parts catalogue code
			(1)	(2)	(3)	(4)		
1	16106-KW7-900	CLIP B, TUBE	1	-	-	-	KRF4, KRS4, KRS5	
2	16271-ZE1-000	PACKING, ELBOW	1	-	-	1	HHQ4, HTF2, HT2, HT24, HX, HXU, HX2, HX26, HX4, KRF4, KRS4, KRS5, LAJ4, LH, LHQ4, LJD2, LTJ, LTS, LX, LXU, LX2, LX4, PX, PX2, QH, QHQ4, QH26, QJG2, QLL, QMA4, QMA8, QMX2, QWA4, QX, QXBR, QXS2, QXU, QX2, QX26, QX4, QX7, RHC, RHQ4, RX, RX4, SAJ4, SAR4, SE, SG24, SH, SHQ4, SJD2, SMA7, SMJ, SMW2, SM11, SM12, SM14, SSK1, SSK3, SSX2, SSX4, STP, SWX2, SWX4, SX, SXS4, SX4, SX7, TX, TXBR, TX2, TX26, TX4, UXU, VEE1, VEK, VEX, VEX7, VMS4, VSX, VSX1, VX, VXBR, VXU, VX4, VX7, WDA6	
3	17210-ZE0-822	ELEMENT, AIR CLEANER (DUAL) -	-	(1)	-	-	HHQ4, HTF2, HT2, HT24, HX, HXU, HX2, HX26, HX4, LAJ4, LH, LHQ4, LJD2, LTJ, LTS, LX, LXU, LX2, LX4, PX, PX2, QH, QHQ4, QH26, QJG2, QLL, QMA4, QMA8, QMX2, QWA4, QX, QXBR, QXS2, QXU, QX2, QX26, QX4, QX7, RHC, RHQ4, RX, RX4, SAJ4, SAR4, SE, SG24, SH, SHQ4, SJD2, SMA7, SMJ, SMW2, SM11, SM12, SM14, SSK1, SSK3, SSX2, SSX4, STP, SWX2, SWX4, SX, SXS4, SX4, SX7, TX, TXBR, TX2, TX26, TX4, UXU, VEE1, VEK, VEX, VEX7, VMS4, VSX, VSX1, VX, VXBR, VXU, VX4, VX7, WDA6	
4	17210-ZE1-822	-	(1)	-	-	KRF4, KRS4, KRS5	
	17218-ZE0-821	FILTER, OUTER	1	-	-	1	HHQ4, HTF2, HT2, HT24, HX, HXU, HX2, HX26, HX4, LAJ4, LH, LHQ4, LJD2, LTJ, LTS, LX, LXU, LX2, LX4, PX, PX2, QH, QHQ4, QH26, QJG2, QLL, QMA4, QMA8, QMX2, QWA4, QX, QXBR, QXS2, QXU, QX2, QX26, QX4, QX7, RHC, RHQ4, RX, RX4, SAJ4, SAR4, SE, SG24, SH, SHQ4, SJD2, SMA7, SMJ, SMW2, SM11, SM12, SM14, SSK1, SSK3, SSX2, SSX4, STP, SWX2, SWX4, SX, SXS4, SX4, SX7, TX, TXBR, TX2, TX26, TX4, UXU, VEE1, VEK, VEX, VEX7, VMS4, VSX, VSX1, VX, VXBR, VXU, VX4, VX7, WDA6	
	17218-ZE1-821	-	(1)	-	-	KRF4, KRS4, KRS5	



E-15

AIR CLEANER(1)

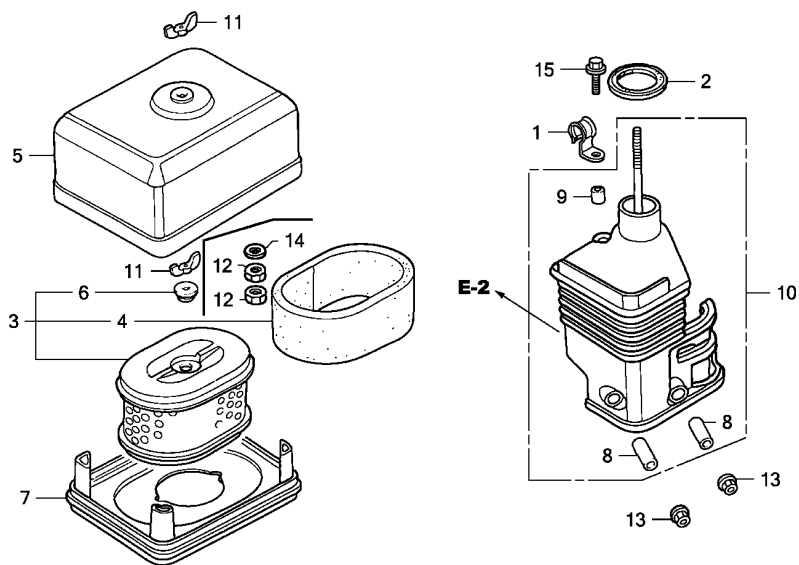

ZK70E1500A



Ref. No.	Part No.	Description	Reqd. QTY				Serial No.	Parts catalogue code
			(1)	(2)	(3)	(4)		
5	17230-ZE0-820	COVER, AIR CLEANER (DUAL) ...	1	-	-	1	-----	HHQ4,HTF2,HT2,HT24,HX,HXU,HX2,HX26,HX4,LAJ4,LH,LHQ4,LJD2,LTJ LTS,LX,LXU,LX2,LX4,PX,PX2,QB26,QH,QHQ4,QH26,QJG2,QLL,QMA4,QMA8 QMX2,QWA4,QX,QXBR,QXS2,QXU,QX2,QX26,QX4,QX7,RHC,RHQ4,RX,RX4 SAJ4,SAR4,SE,SG24,SH,SHQ4,SJD2,SMA7,SMJ,SMW2,SM11,SM12,SM14 SSK1,SSK3,SSX2,SSX4,STP,SWX2,SWX4,SX,SXS4,SX4,SX7,TX,TXBR,TX2 TX26,TX4,UXU,VEE1,VEK,VEX,VEX7,VMS4,VSX,VSX1,VX,VXBR,VXU,VX4 VX7,WDA6
	17230-ZE1-820	-	(1)	-	-	-----	KRF4,KRS4,KRS5
6	17232-891-000	GROMMET, AIR CLEANER	1	-	-	1	-----	HHQ4,HTF2,HT2,HT24,HX,HXU,HX2,HX26,HX4,KRF4,KRS4,KRS5,LAJ4,LH LHQ4,LJD2,LTJ,LTS,LX,LXU,LX2,LX4,PX,PX2,QH,QHQ4,QH26,QJG2,QLL QMA4,QMA8,QMX2,QWA4,QX,QXBR,QXS2,QXU,QX2,QX26,QX4,QX7,RHC,RHQ4 RX,RX4,SAJ4,SAR4,SE,SG24,SH,SHQ4,SJD2,SMA7,SMJ,SMW2,SM11,SM12 SM14,SSK1,SSK3,SSX2,SSX4,STP,SWX2,SWX4,SX,SXS4,SX4,SX7,TX,TXBR TX2,TX26,TX4,UXU,VEE1,VEK,VEX,VEX7,VMS4,VSX,VSX1,VX,VXBR,VXU VX4,VX7,WDA6
7	17235-ZE1-831	NOSE, SILENCER	1	-	-	-	-----	KRS4,KRS5,QLL,QMA8,QMX2,QWA4,QX7,SE,SG24,SJD2,SMA7,SM11,SM12 SM14,SSK1,SSK3,SSX2,SSX4,STP,SX7,VEE1,VEK,VEX7,VMS4,VX7
8	17238-ZE0-010	COLLAR, AIR CLEANER	2	-	-	2	-----	HHQ4,HTF2,HT2,HT24,HX,HXU,HX2,HX26,HX4,LAJ4,LH,LHQ4,LJD2,LTJ LTS,LX,LXU,LX2,LX4,PX,PX2,QB26,QH,QHQ4,QH26,QJG2,QLL,QMA4,QMA8 QMX2,QWA4,QX,QXBR,QXS2,QXU,QX2,QX26,QX4,QX7,RHC,RHQ4,RX,RX4 SAJ4,SAR4,SE,SG24,SH,SHQ4,SJD2,SMA7,SMJ,SMW2,SM11,SM12,SM14 SSK1,SSK3,SSX2,SSX4,STP,SWX2,SWX4,SX,SXS4,SX4,SX7,TX,TXBR,TX2 TX26,TX4,UXU,VEE1,VEK,VEX,VEX7,VMS4,VSX,VSX1,VX,VXBR,VXU,VX4 VX7,WDA6
			-	(2)	-	-		

Ref. No.	Part No.	Description	Reqd. QTY				Serial No.	Parts catalogue code
			(1)	(2)	(3)	(4)		
(8)	17238-ZE7-010	COLLAR, AIR CLEANER	2	-	-	-	KRF4, KRS4, KRS5	
9	17239-ZE1-000	COLLAR B, AIR CLEANER	1	-	-	1	HHQ4, HTF2, HT2, HT24, HX, HXU, HX2, HX26, HX4, KRF4, KRS4, KRS5, LAJ4, LH, LHQ4, LJD2, LTJ, LTS, LX, LXU, LX2, LX4, PX, PX2, QB26, QH, QHQ4, QH26, QJG2, QLL, QMA4, QMA8, QMX2, QWA4, QX, QXBR, QXS2, QXU, QX2, QX26, QX4, QX7, RHC, RHQ4, RX, RX4, SAJ4, SAR4, SE, SG24, SH, SHQ4, SJD2, SMA7, SMJ, SMW2, SM11, SM12, SM14, SSK1, SSK3, SSS2, SSS4, STP, SWX2, SWX4, SX, SXS4, SX4, SX7, TX, TXBR, TX2, TX26, TX4, UXU, VEE1, VEK, VEX, VEX7, VMS4, VXS, VXS1, VX, VXBR, VXU, VX4, VX7, WDA6	
10	17410-ZE0-030	ELBOW COMP., AIR CLEANER	-	(1)	-	-	HHQ4, HTF2, HT2, HT24, HX, HXU, HX2, HX26, HX4, LAJ4, LH, LHQ4, LJD2, LTJ, LTS, LX, LXU, LX2, LX4, PX, PX2, QB26, QH, QHQ4, QH26, QJG2, QLL, QMA4, QMA8, QMX2, QWA4, QX, QXBR, QXS2, QXU, QX2, QX26, QX4, QX7, RHC, RHQ4, RX, RX4, SAJ4, SAR4, SE, SG24, SH, SHQ4, SJD2, SMA7, SMJ, SMW2, SM11, SM12, SM14, SSK1, SSK3, SSS2, SSS4, STP, SWX2, SWX4, SX, SXS4, SX4, SX7, TX, TXBR, TX2, TX26, TX4, UXU, VEE1, VEK, VEX, VEX7, VMS4, VXS, VXS1, VX, VXBR, VXU, VX4, VX7, WDA6	
	17410-ZE1-020	-	(1)	-	-	KRF4, KRS4, KRS5	
11	90325-044-000	NUT, TOOL BOX SETTING	1	-	-	-	QB26	
			2	-	-	2	HHQ4, HTF2, HT2, HT24, HX, HXU, HX2, HX26, HX4, KRF4, KRS4, KRS5, LAJ4, LH, LHQ4, LJD2, LTJ, LTS, LX, LXU, LX2, LX4, PX, PX2, QH, QHQ4, QH26, QJG2, QLL, QMA4, QMA8, QMX2, QWA4, QX, QXBR, QXS2, QXU, QX2, QX26, QX4, QX7, RHC, RHQ4, RX, RX4, SAJ4, SAR4, SE, SG24, SH, SHQ4, SJD2, SMA7, SMJ, SMW2, SM11, SM12, SM14, SSK1, SSK3, SSS2, SSS4, STP, SWX2, SWX4, SX, SXS4, SX4, SX7, TX, TXBR, TX2, TX26, TX4, UXU, VEE1, VEK, VEX, VEX7, VMS4, VXS, VXS1, VX, VXBR, VXU, VX4, VX7, WDA6	
12	94001-06000-0S	NUT, HEX., 6MM	-	(2)	-	-	QB26	
13	94050-06000	NUT, FLANGE, 6MM	2	-	-	2	HHQ4, HTF2, HT2, HT24, HX, HXU, HX2, HX26, HX4, KRF4, KRS4, KRS5, LAJ4, LH, LHQ4, LJD2, LTJ, LTS, LX, LXU, LX2, LX4, PX, PX2, QB26, QH, QHQ4, QH26, QJG2, QLL, QMA4, QMA8, QMX2, QWA4, QX, QXBR, QXS2, QXU, QX2, QX26, QX4, QX7, RHC, RHQ4, RX, RX4, SAJ4, SAR4, SE, SG24, SH, SHQ4, SJD2, SMA7, SMJ, SMW2, SM11, SM12, SM14, SSK1, SSK3, SSS2, SSS4, STP, SWX2, SWX4, SX, SXS4, SX4, SX7, TX, TXBR, TX2, TX26, TX4, UXU, VEE1, VEK, VEX, VEX7, VMS4, VXS, VXS1, VX, VXBR, VXU, VX4, VX7, WDA6	
14	94101-06800	WASHER, PLAIN, 6MM	-	2	-	-	QB26	
15	95701-06020-00	BOLT, FLANGE, 6X20	1	-	-	1	HHQ4, HTF2, HT2, HT24, HX, HXU, HX2, HX26, HX4, KRF4, KRS4, KRS5, LAJ4, LH, LHQ4, LJD2, LTJ, LTS, LX, LXU, LX2, LX4, PX, PX2, QB26, QH, QHQ4, QH26, QJG2, QLL, QMA4, QMA8, QMX2, QWA4, QX, QXBR, QXS2, QXU, QX2, QX26, QX4, QX7, RHC, RHQ4, RX, RX4, SAJ4, SAR4, SE, SG24, SH, SHQ4, SJD2, SMA7, SMJ, SMW2, SM11, SM12, SM14, SSK1, SSK3, SSS2, SSS4, STP, SWX2, SWX4, SX, SXS4, SX4, SX7, TX, TXBR, TX2, TX26, TX4, UXU, VEE1, VEK, VEX, VEX7, VMS4, VXS, VXS1, VX, VXBR, VXU, VX4, VX7, WDA6	
			-	1	-	-		



E-15-1

AIR CLEANER(2)

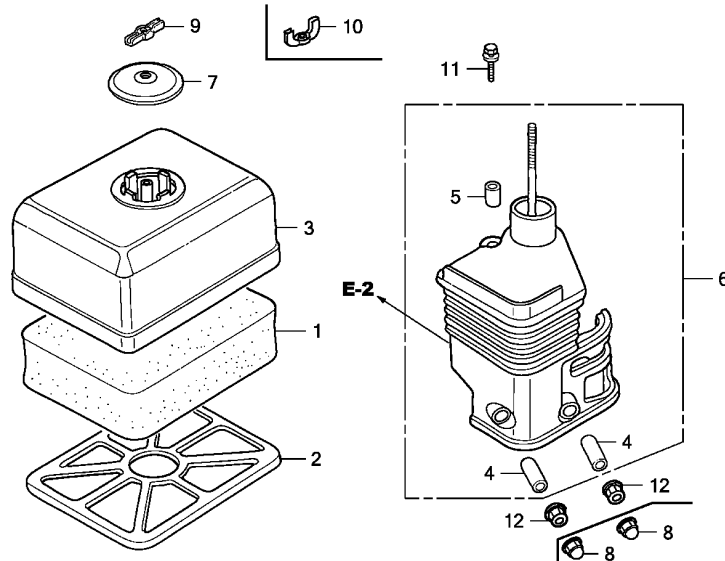

Ref. No.	L.O.N.	(Relative ref. Number) Description	F.R.T.
1	3121B8	ELEMENT, AIR CLEANERINCLUDES: Air cleaner- inspection	0.1
6	3121B4	ELBOW, AIR CLEANER	0.1

Ref. No.	Part No.	Description	Reqd. QTY				Serial No.	Parts catalogue code
			(1)	(2)	(3)	(4)		
1	17211-ZE1-000	ELEMENT, AIR CLEANER (SEMI DRY)	1	-	-	1	-----	DS, LAJ, LD, LJ, LJC, LJC8, LJS, LSJ, LSJ4, LTR, QD, QDBR, QM, RD, RD4, SAJ, SCJ, SD, SD16, SD4, SJ, SJC1, SJC5, SKR, SYA, VED, VED1, VED6, VET, WD12, WJ, WJP, WKD6, WKT2, WKT4, WKT6, WMA3, WMA4, WME2, WME4, WMK, WM1
2	17212-ZE1-000	GRID, AIR CLEANER (SEMI DRY)	1	(1)	1	-	-----	DS, LAJ, LD, LJ, LJC, LJC8, LJS, LSJ, LSJ4, LTR, QD, QDBR, QM, RD, RD4, SAJ, SCJ, SD, SD16, SD4, SJ, SJC1, SJC5, SKR, SYA, VED, VED1, VED6, VET, WD12, WJ, WJP, WKD6, WKT2, WKT4, WKT6, WMA3, WMA4, WME2, WME4, WMK, WM1
3	17231-ZE0-000	COVER, AIR CLEANER (SEMI DRY)	1	(1)	1	-	-----	DS, LAJ, LD, LJ, LJC, LJC8, LJS, LSJ, LSJ4, LTR, QD, QDBR, QM, RD, RD4, SAJ, SCJ, SD, SD16, SD4, SJ, SJC1, SJC5, SKR, SYA, VED, VED1, VED6, VET, WD12, WJ, WJP, WKD6, WKT2, WKT4, WKT6, WMA3, WMA4, WME2, WME4, WMK, WM1
4	17238-ZE0-010	COLLAR, AIR CLEANER	2	(1)	1	-	-----	DS, LAJ, LD, LJ, LJC, LJC8, LJS, LSJ, LSJ4, LTR, QD, QDBR, QM, RD, RD4, SAJ, SCJ, SD, SD16, SD4, SJ, SJC1, SJC5, SKR, SYA, VED, VED1, VED6, VET, WD12, WJ, WJP, WKD6, WKT2, WKT4, WKT6, WMA3, WMA4, WME2, WME4, WMK, WM1
5	17239-ZE1-000	COLLAR B, AIR CLEANER	1	(2)	2	-	-----	DS, LAJ, LD, LJ, LJC, LJC8, LJS, LSJ, LSJ4, LTR, QD, QDBR, QM, RD, RD4, SAJ, SCJ, SD, SD16, SD4, SJ, SJC1, SJC5, SKR, SYA, VED, VED1, VED6, VET, WD12, WJ, WJP, WKD6, WKT2, WKT4, WKT6, WMA3, WMA4, WME2, WME4, WMK, WM1
6	17410-ZE0-030	ELBOW COMP., AIR CLEANER	1	(1)	1	-	-----	DS, LAJ, LD, LJ, LJC, LJC8, LJS, LSJ, LSJ4, LTR, QD, QDBR, QM, RD, RD4, SAJ, SCJ, SD, SD16, SD4, SJ, SJC1, SJC5, SKR, SYA, VED, VED1, VED6, VET, WD12, WJ, WJP, WKD6, WKT2, WKT4, WKT6, WMA3, WMA4, WME2, WME4, WMK, WM1
	17410-ZE0-811	-	(1)	1	-	-----	

E-15-1

AIR CLEANER(2)

H 6

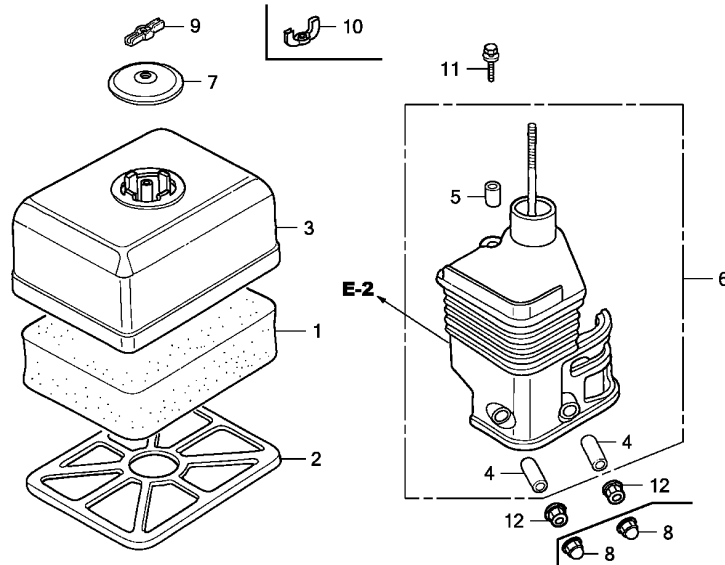

Ref. No.	Part No.	Description	Reqd. QTY				Serial No.	Parts catalogue code
			(1)	GX120K1 (2)	(3)	(4)		
7	17421-ZE1-000	CAP, CLEANER	1	-	-	1	-----	DS, LAJ, LD, LJ, LJC, LJC8, LJS, LSJ, LSJ4, LTR, QD, QDBR, QM, RD, RD4, SAJ, SCJ, SD, SD16, SD4, SJ, SJC1, SJC5, SKR, SYA, VED, VED1, VED6, VET, WD12, WJ, WJP, WKD6, WKT2, WKT4, WKT6, WMA3, WMA4, WME2, WME4, WMK, WM1
8	90201-415-000	NUT, CAP, 6MM	-	(1)	1	-	-----	SIH
9	90203-ZA0-800	NUT, WING, 6MM(BLACK)	-	-	1	-	-----	2336263 SIH, WIH
10	90325-044-000	NUT, TOOL BOX SETTING	1	-	1	1	-----	DS, LAJ, LD, LJ, LJC, LJC8, LJS, LSJ, LSJ4, LTR, QD, QDBR, QM, RD, RD4, SAJ, SCJ, SD, SD16, SD4, SJ, SJC1, SJC5, SKR, SYA, VED, VED1, VED6, VET, WD12, WIS, WJ, WJP, WKD6, WKT2, WKT4, WKT6, WMA3, WMA4, WME2, WME4, WMK, WM1
			-	(1)	-	-	-----	
			-	-	1	-	2336264	----- SIH, WIH
11	93494-06020-08	BOLT-WASHER, 6X20	-	-	1	-	-----	SIH
	95701-06020-00	BOLT, FLANGE, 6X20	1	-	1	1	-----	DS, LAJ, LD, LJ, LJC, LJC8, LJS, LSJ, LSJ4, LTR, QD, QDBR, QM, RD, RD4, SAJ, SCJ, SD, SD16, SD4, SJ, SJC1, SJC5, SKR, SYA, VED, VED1, VED6, VET, WD12, WIH, WIS, WJ, WJP, WKD6, WKT2, WKT4, WKT6, WMA3, WMA4, WME2, WME4, WMK, WM1
12	94050-06000	NUT, FLANGE, 6MM	-	1	-	-	-----	DS, LAJ, LD, LJ, LJC, LJC8, LJS, LSJ, LSJ4, LTR, QD, QDBR, QM, RD, RD4, SAJ, SCJ, SD, SD16, SD4, SJ, SJC1, SJC5, SKR, SYA, VED, VED1, VED6, VET, WD12, WJ, WJP, WKD6, WKT2, WKT4, WKT6, WMA3, WMA4, WME2, WME4, WMK, WM1
			-	2	2	-	-----	

2

E-15-2

AIR CLEANER(3)

H 7

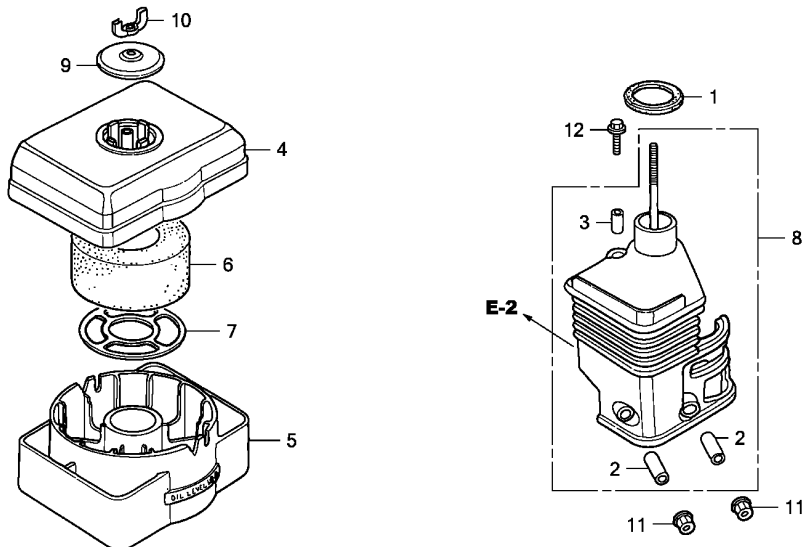

ZK70E1502A

Ref. No.	L.O.N.	(Relative ref. Number) Description	F.R.T.
1	3121E1	PACKING, ELBOW	0.1
5	3121E5	PAN, AIR CLEANER OIL	0.1
6	3121B8	ELEMENT, AIR CLEANER	0.1
		.INCLUDES: Air cleaner- inspection	
8	3121B4	ELBOW, AIR CLEANER	0.1

Ref. No.	Part No.	Description	Reqd. QTY				Serial No.	Parts catalogue code
			(1)	GX120K1 (2)	(3)	(4)		
1	16271-ZE1-000	PACKING, ELBOW	1	-	-	-	LTK1,QA,QA2,QME4,QT	
2	17238-ZE0-010	COLLAR, AIR CLEANER	2	-	-	-	LTK1,QA,QA2,QME4,QT	
3	17239-ZE1-000	COLLAR B, AIR CLEANER	1	-	-	-	LTK1,QA,QA2,QME4,QT	
4	17401-ZE1-810	BODY, CLEANER (OIL BATH)	1	-	-	-	LTK1,QA,QA2,QME4,QT	
5	17402-ZE1-810	PAN, CLEANER OIL (OIL BATH) -	1	-	-	-	LTK1,QA,QA2,QME4,QT	
6	17403-ZE1-810	ELEMENT, AIR CLEANER (OIL BATH)	1	-	-	-	LTK1,QA,QA2,QME4,QT	
7	17404-841-000	GRID, AIR CLEANER	1	-	-	-	LTK1,QA,QA2,QME4,QT	
8	17410-ZE0-811	ELBOW COMP., AIR CLEANER	1	-	-	-	LTK1,QA,QA2,QME4,QT	
9	17421-ZE1-000	CAP, CLEANER	1	-	-	-	LTK1,QA,QA2,QME4,QT	
10	90325-044-000	NUT, TOOL BOX SETTING	1	-	-	-	LTK1,QA,QA2,QME4,QT	
11	94050-06000	NUT, FLANGE, 6MM	2	-	-	-	LTK1,QA,QA2,QME4,QT	
12	95701-06020-00	BOLT, FLANGE, 6X20	1	-	-	-	LTK1,QA,QA2,QME4,QT	

2

E-15-3

AIR CLEANER(4)

H 8

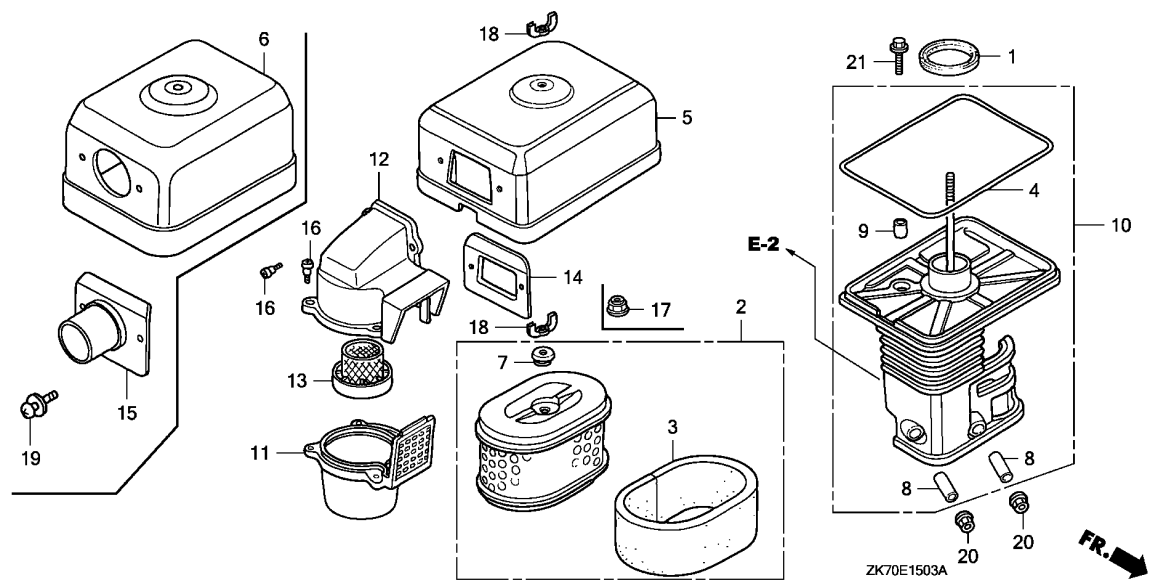

Ref. No.	L.O.N.	(Relative ref. Number) Description	F.R.T.
1	3121E1	PACKING, ELBOW	0.1
2	3121B8	ELEMENT, AIR CLEANER	0.1
		.INCLUDES: Air cleaner- inspection	
3	3121C1	FILTER, OUTER	0.1
4	3121E0	PACKING, AIR CLEANER COVER ...	0.1
10	3121B4	ELBOW, AIR CLEANER	0.1
11	3121A6	CASE, PRE AIR CLEANER	0.1
12	3121A4	CAP, PRE AIR CLEANER	0.1
13	3121C8	GUIDE, PRE AIR CLEANER	0.1

Ref. No.	Part No.	Description	Reqd. QTY				Serial No.	Parts catalogue code
			(1)	GX120K1 (2)	(3)	(4)		
1	16271-ZE1-000	PACKING, ELBOW	1	-	-	-	QXC9,STS	
2	17210-ZE1-822	ELEMENT, AIR CLEANER (DUAL) ..	1	-	-	-	QXC9,STS	
3	17218-ZE1-821	FILTER, OUTER	1	-	-	-	QXC9,STS	
4	17219-733-010	PACKING, AIR CLEANER COVER ..	1	-	-	-	QXC9,STS	
5	17230-ZE1-841	COVER, AIR CLEANER (DUAL) ...	1	-	-	-	QXC9	
6	17230-ZE1-850	COVER, AIR CLEANER	1	-	-	-	STS	
7	17232-891-000	GROMMET, AIR CLEANER	1	-	-	-	QXC9,STS	
8	17238-ZE0-010	COLLAR, AIR CLEANER	2	-	-	-	QXC9,STS	
9	17239-733-000	COLLAR B, AIR CLEANER	1	-	-	-	QXC9,STS	
10	17410-ZE0-840	ELBOW COMP., AIR CLEANER	1	-	-	-	QXC9,STS	
11	17470-ZE1-842	CASE, PRE AIR CLEANER	1	-	-	-	QXC9	
12	17475-ZE1-841	CAP, PRE AIR CLEANER	1	-	-	-	QXC9	
13	17476-ZE1-841	GUIDE, PRE AIR CLEANER	1	-	-	-	QXC9	
14	17478-ZE1-841	PLATE, PRE AIR CLEANER	1	-	-	-	QXC9	

2

E-15-3

AIR CLEANER(4)

H 9

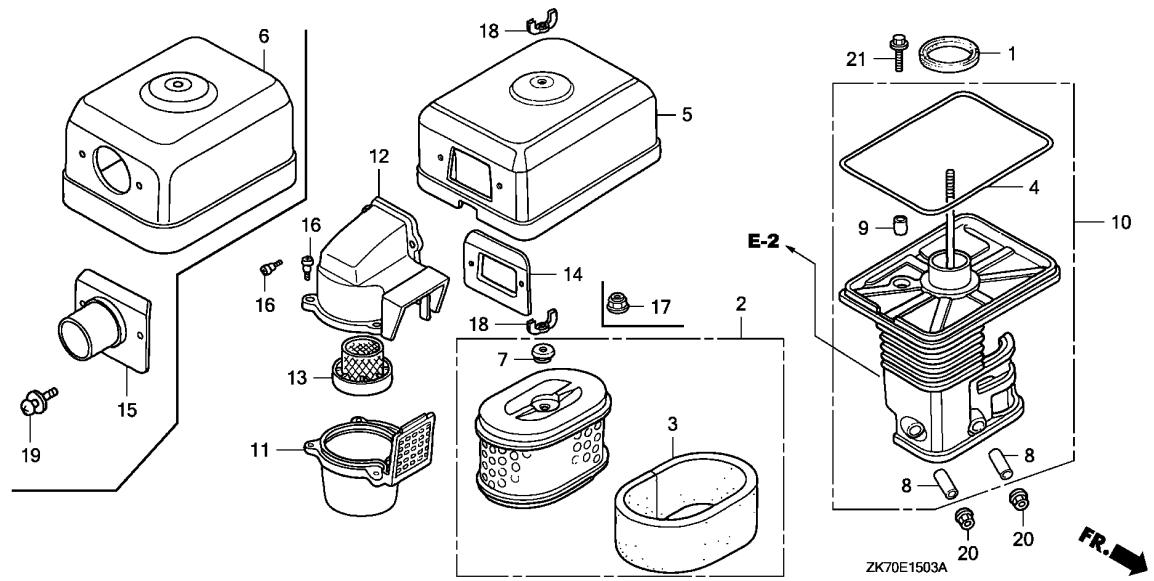

Ref. No.	Part No.	Description	Reqd. QTY				Serial No.	Parts catalogue code
			(1)	GX120K1 (2)	(3)	(4)		
15	17478-ZE1-850	PLATE, PRE AIR CLEANER	1	-	-	-	STS	
16	90300-GB0-900	BOLT, MUDGUARD	5	-	-	-	QXC9	
			-	(5)	-	-		
17	90301-473-003	NUT, U, 6MM	1	-	-	-	STS	
18	90325-044-000	NUT, TOOL BOX SETTING	1	-	-	-	STS	
			2	-	-	-	QXC9	
			-	(2)	-	-		
19	93893-04012-07	SCREW-WASHER, 4X12	2	-	-	-	STS	
20	94050-06000	NUT, FLANGE, 6MM	2	-	-	-	QXC9,STS	
			-	2	-	-		
21	95701-06020-00	BOLT, FLANGE, 6X20	1	-	-	-	QXC9,STS	
			-	(1)	-	-		

2

E-15-4

AIR CLEANER(5)

H10

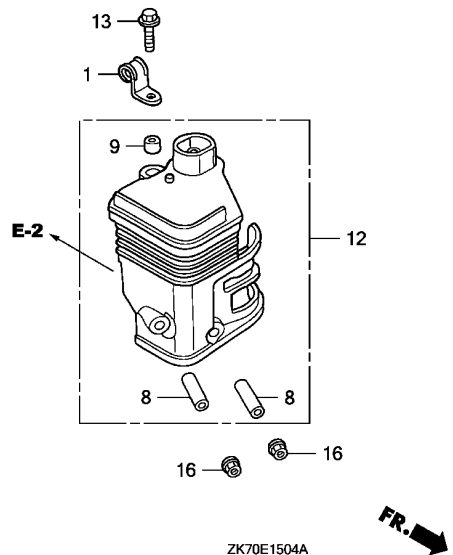
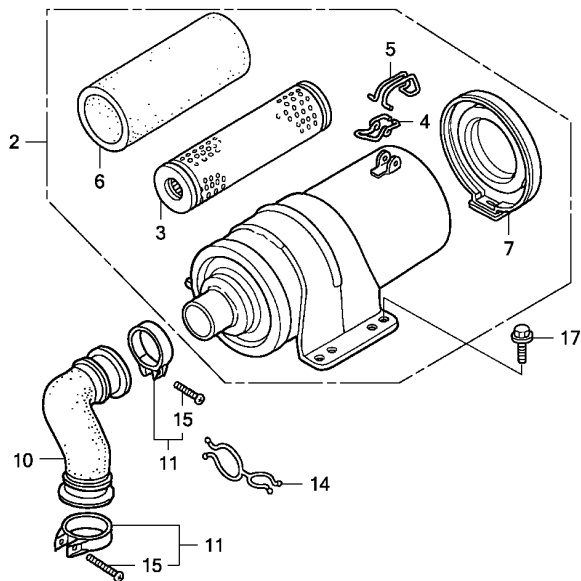

Ref. No.	L.O.N.	(Relative ref. Number) Description	F.R.T.
2	3121B0	CLEANER, AIR	0.1
3	3121B8	ELEMENT, AIR CLEANER	0.1
.INCLUDES: Air cleaner- inspection			
6	3121C1	FILTER, OUTER	0.1
10	3121F9	TUBE, AIR CLEANER INTAKE	0.1
12	3121B4	ELBOW, AIR CLEANER	0.1

Ref. No.	Part No.	Description	Reqd. QTY				Serial No.	Parts catalogue code
			(1)	GX120K1 (2)	(3)	(4)		
1	16106-KW7-900	CLIP B, TUBE	1	-	-	-	AR,ARL,DKR,KR,KRA4,KRS6	
2	17200-ZK7-V01	CLEANER ASSY., AIR	1	-	-	-	AR,ARL,DKR,KR,KRA4,KRT,KRT4,KRT6	
3	17210-ZK7-V01	ELEMENT COMP., AIR CLEANER ..	1	-	-	-	AR,ARL,DKR,KR,KRA4,KRT,KRT4,KRT6	
4	17216-PM4-300	CLIP A, WIRE	1	-	-	-	AR,ARL,DKR,KR,KRA4,KRT,KRT4,KRT6	
5	17217-PM4-300	CLIP B, WIRE	1	-	-	-	AR,ARL,DKR,KR,KRA4,KRT,KRT4,KRT6	
6	17218-ZK7-V01	FILTER, OUTER	1	-	-	-	AR,ARL,DKR,KR,KRA4,KRT,KRT4,KRT6	
7	17230-ZK7-V01	COVER COMP., AIR CLEANER	1	-	-	-	AR,ARL,DKR,KR,KRA4,KRT,KRT4,KRT6	
8	17238-ZE7-010	COLLAR, AIR CLEANER	2	-	-	-	AR,ARL,DKR,KR,KRA4,KRS6,KRT,KRT4,KRT6	
9	17239-ZE1-000	COLLAR B, AIR CLEANER	1	-	-	-	AR,ARL,DKR,KR,KRA4,KRS6,KRT,KRT4,KRT6	
10	17251-ZE0-S10	TUBE, AIR CLEANER CONNECTING	1	-	-	-	AR,ARL,DKR,KR,KRA4,KRT,KRT4,KRT6	
11	17255-758-000	BAND, AIR CLEANER CONNECTING						
		TUBE	2	-	-	-	AR,ARL,DKR,KR,KRA4,KRT,KRT4,KRT6	
12	17410-ZE1-P30	ELBOW COMP., AIR CLEANER	1	-	-	-	AR,ARL,DKR,KR,KRA4,KRS6,KRT,KRT4,KRT6	
13	95701-06020-00	BOLT, FLANGE, 6X20	1	-	-	-	AR,ARL,DKR,KR,KRA4,KRS6,KRT,KRT4,KRT6	
14	91473-PA1-003	CLIP, WATER HOSE	1	-	-	-	KR,KRT,KRT6	
15	93500-04020-0A	SCREW, PAN, 4X20	2	-	-	-	AR,ARL,DKR,KR,KRA4,KRT,KRT4,KRT6	
16	94050-06000	NUT, FLANGE, 6MM	2	-	-	-	AR,ARL,DKR,KR,KRA4,KRS6,KRT,KRT4,KRT6	
17	95701-06016-00	BOLT, FLANGE, 6X16	2	-	-	-	AR,ARL,DKR,KR,KRA4,KRT,KRT4,KRT6	

2

E-15-5

AIR CLEANER(6)

H11

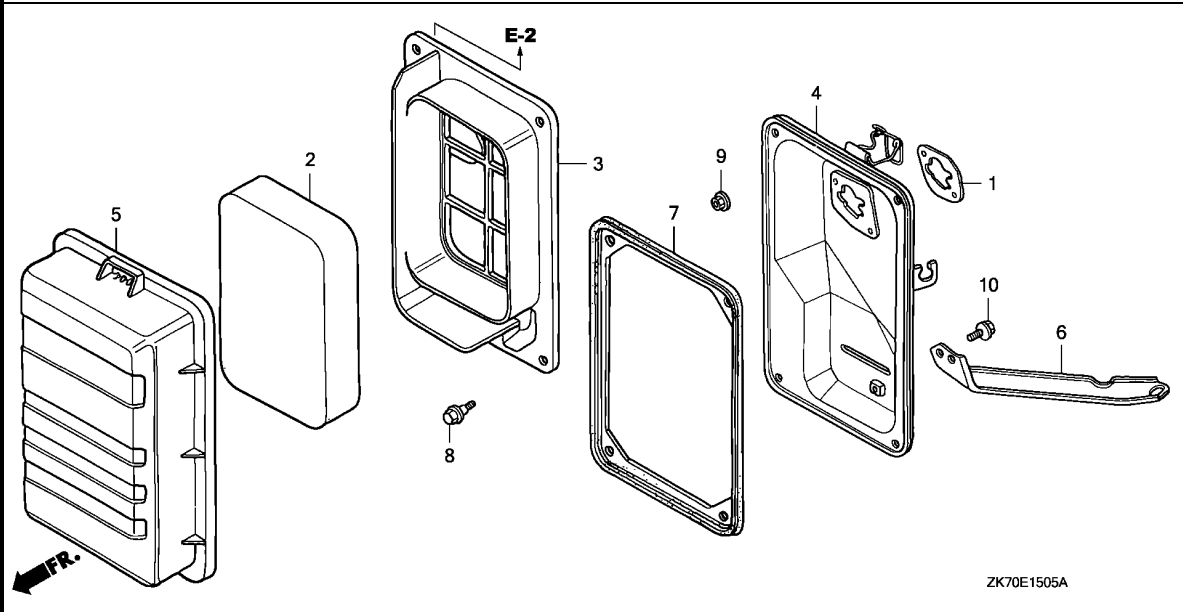

Ref. No.	L.O.N.	(Relative ref. Number) Description	F.R.T.
1	3121D9	PACKING, AIR CLEANER	0.1
2	3121B8	ELEMENT, AIR CLEANER	0.1
		.INCLUDES: Air cleaner- inspection	
3	3121F0	SEPARATOR, AIR CLEANER	0.1
4	3121A5	CASE, AIR CLEANER	0.1
7	3121E8	SEAL, AIR CLEANER CASE	0.1

Ref. No.	Part No.	Description	Reqd. QTY				Serial No.	Parts catalogue code
			(1)	GX120K1 (2)	(3)	(4)		
1	16269-ZE1-800	PACKING, AIR CLEANER	1	-	-	-	VMT,VPM4,VPR4	
2	17211-ZB2-000	ELEMENT, AIR CLEANER	1	-	-	-	VMT,VPM4,VPR4	
3	17212-ZB2-000	SEPARATOR, AIR CLEANER	1	-	-	-	VMT,VPM4,VPR4	
4	17220-ZB2-000	CASE COMP., AIR CLEANER	1	-	-	-	VMT,VPM4,VPR4	
5	17231-ZB2-000	COVER, AIR CLEANER	1	-	-	-	VMT,VPM4,VPR4	
6	17239-ZB2-000	STAY, AIR CLEANER	1	-	-	-	VMT,VPM4,VPR4	
7	17252-ZB2-000	SEAL, AIR CLEANER	1	-	-	-	VMT,VPM4,VPR4	
8	90115-459-770	BOLT, WINKER SETTING	4	-	-	-	VMT,VPM4,VPR4	
9	94050-06080	NUT, FLANGE, 6MM	2	-	-	-	VMT,VPM4,VPR4	
10	95701-06010-00	BOLT, FLANGE, 6X10	1	-	-	-	VMT,VPM4,VPR4	

2

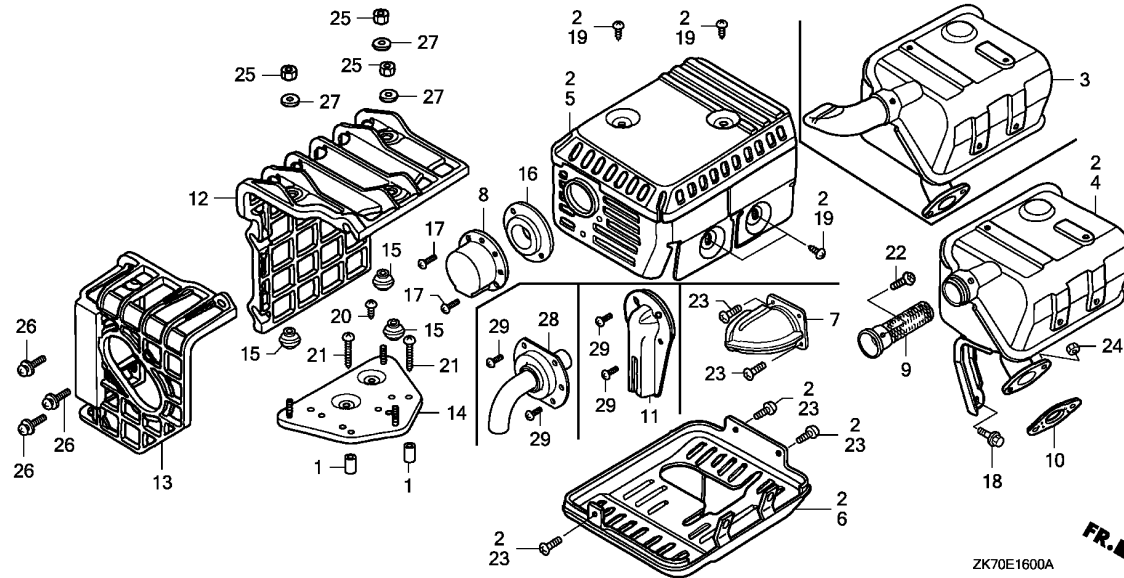

Ref. No.	L.O.N.	(Relative ref. Number) Description	F.R.T.
2	3131C3	MUFFLER ASSEMBLY, EXHAUST (3)	0.2
4	3131C5	MUFFLER, EXHAUST	0.2
5	3131D5	PROTECTOR, EXHAUST MUFFLER :UPPER	0.2
6	3131D2	PROTECTOR, EXHAUST MUFFLER :LOWER	0.2
9	3131A1	ARRESTER, SPARK .INCLUDES: Spark arrester check	0.2
10	3131B4	GASKET, EXHAUST MUFFLER	0.2
12	3131A7	COVER, EXHAUST MUFFLER	0.1
13	3131A6	COVER, EXHAUST MUFFLER :REAR	0.1
14	3131A2	BASE, EXHAUST MUFFLER COVER	0.2

Ref. No.	Part No.	Description	Reqd. QTY				Serial No.	Parts catalogue code
			(1)	(2)	(3)	(4)		
1	17233-896-701	COLLAR, AIR CLEANER CASE	(2)	-	-	-	HHQ4, HT24, HX4, LAJ4, LHQ4, LSJ4, LX4, QHQ4, QLL, QMA4, QME4, QX4, QX7, RD4, RHQ4, RX4, SAJ4, SAR4, SD4, SHQ4, SM12, SWX2, SXS4, SX4, SX7, TX4, VEX, VEX7, VX4, VX7, WDA6, WD12, WKT4, WMA3, WMA4, WMK, WM1	
2	18300-ZH8-840	MUFFLER ASSY. (LOWER PROTECTOR)	1	-	-	-	DS, LAJ, LJ, LJC, LJC8, LJS, LSJ, LTJ, LTK1, LTR, LTS, QXS2, SAJ, SCJ, SJ, SJC1, SJC5, SKR, SMJ, VET, WJ, WJP	
3	18310-ZE0-A20	MUFFLER COMP.	1	-	-	-	VEK	
4	18310-ZE1-900	MUFFLER COMP.	1	-	-	-	STP, STS	
	18310-ZF1-000	MUFFLER COMP. (STD.)	1	-	-	-	DS, HHQ4, HTF2, HT2, HT24, HX, HXU, HX2, HX26, HX4, LAJ, LAJ4, LD, LH, LHQ4, LJ, LJC, LJC8, LJD2, LJS, LSJ, LSJ4, LTJ, LTK1, LTR, LTS, LX, LXU, LX2, LX4, PX, PX2, QB26, QD, QH, QHQ4, QH26, QJG2, QLL, QM, QMA4, QME4, QT, QX, QXS2, QXU, QX2, QX26, QX4, RD, RD4, RHQ4, RX, RX4, SAJ, SAJ4, SCJ, SD, SD16, SD4, SH, SHQ4, SJ, SJC1, SJC5, SKR, SMJ, SWX2, SWX4, SX, SX4, TX, TX2, TX26, TX4, UXU, VED, VET, VEX, VX, VXU, VX4, WDA6, WJ, WJP, WMA3, WMA4, WME4, WMK, WM1	
	18310-ZH7-V90	MUFFLER COMP.	-	(1)	1	1	SM11, SM14	
	18310-ZH8-T30	MUFFLER COMP. (SAKAI-ARRESTER)	1	-	-	-	SSK1, SSK3, SSS2, SSS4	
	18310-ZH8-810	MUFFLER COMP. (ARRESTER)	1	-	-	-	QA, QA2, QMX2, QX7, RHC, SAR4, SMW2, SXS4, SX7, VED1, VED6, VEX7, VX7, WD12, WKD6, WKT2, WKT4, WKT6, WME2	
			(1)	-	-	(1)	ARL, HTF2, HT2, HT24, HX, HXU, HX2, HX26, HX4, QJG2, QLL, QX, QXBR, QXS2, QXU, QX2, QX26, QX4, SWX2, SWX4, TX, TXBR, TX2, TX26, TX4, WMA4	
	18310-ZK8-V50	MUFFLER COMP.	-	(1)	-	-	SM12	
5	18320-ZE1-T02	PROTECTOR, UPPER (CHROME PLATED)	-	-	1	-	SIH, WIH	



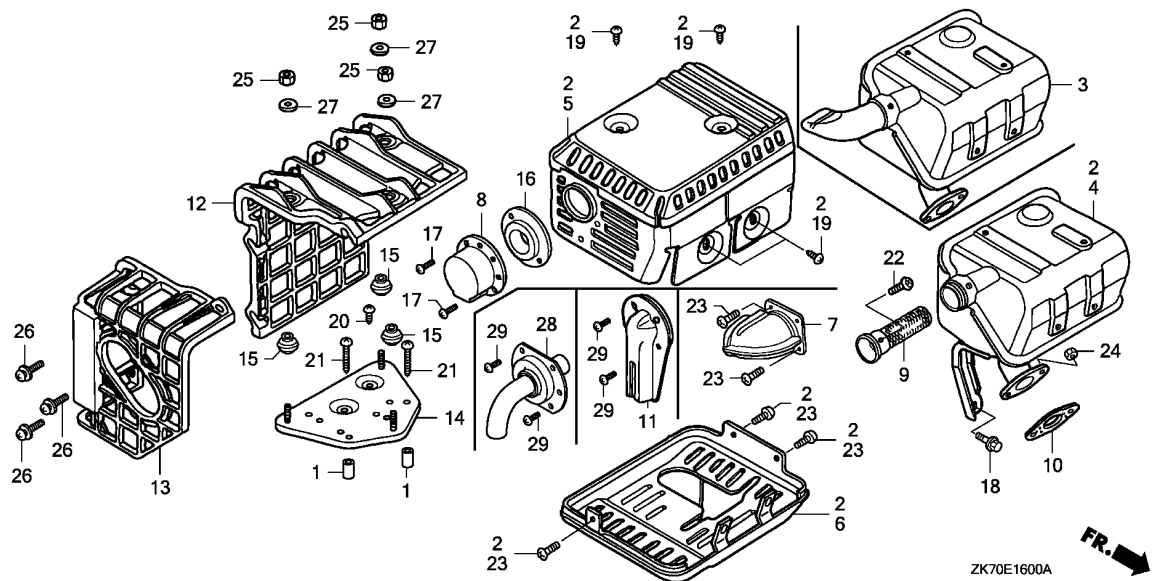

ZK70E1600A

Ref. No.	Part No.	Description	Reqd. QTY				Serial No.	Parts catalogue code
			(1)	(2)	(3)	(4)		
(5)	18320-ZF1-H01	PROTECTOR, MUFFLER (STD.) (BLACK)	1	-	-	-	DS,HHQ4,HTF2,HT2,HT24,HX,HXU,HX2,HX26,HX4,LAJ,LAJ4,LD,LH,LHQ4 LJ,LJC,LJC8,LJD2,LJS,LSJ,LSJ4,LTJ,LTK1,LTR,LTS,LX,LXU,LX2,LX4 PX,PX2,QA,QA2,QD,QH,QHQ4,QH26,QJG2,QLL,QM,QMA4,QME4,QMX2,QT,QX QXS2,QXU,QX2,QX26,QX4,QX7,RD,RD4,RHC,RHQ4,RX,RX4,SAJ,SAJ4,SAR4 SCJ,SD,SD16,SD4,SH,SHQ4,SJ,SJC1,SJC5,SKR,SMJ,SMW2,SM11,SM12 SM14,SSK1,SSK3,SSX2,SSX4,STP,STS,SWX2,SWX4,SX,SXS4,SX4,SX7,TX TX2,TX26,TX4,UXU,VED,VED1,VED6,VEK,VET,VEX,VEX7,VX,VXU,VX4,VX7 WDA6,WD12,WJ,WJP,WKD6,WKT2,WKT4,WKT6,WMA3,WMA4,WME2,WME4,WMK	
	18320-ZH8-W01	PROTECTOR, MUFFLER (ALUMINIZED)	1	(1)	1	1	WM1	
6	18325-ZE1-010	PROTECTOR, LOWER	1	-	-	-	DS,LAJ,LJ,LJC,LJC8,LJS,LSJ,LSJ4,LTJ,LTK1,LTR,LTS,QXS2,SAJ,SCJ,SJ SJC1,SJC5,SKR,SMJ,VEK,VET,WJ,WJP	
7	18340-ZE0-A60	PROTECTOR, TAIL PIPE	1	(1)	-	-	VEK	
8	18340-ZE1-010	DEFLECTOR COMP.	1	-	-	-	HTF2,LAJ,LAJ4,LJD2,LJS,LSJ,LSJ4,LTJ,LTK1,LTR,QA,QA2,QLL,QMA4 QMX2,QT,SAJ,SAJ4,SAR4,SCJ,SJC1,SJC5,SKR,SMW2,SM11,SM12,SM14 SSK1,SSK3,SSX2,SSX4,STP,STS,SXS4,VEX,VEX7	
9	18355-ZE1-000	ARRESTER, SPARK	1	(1)	-	-	QA,QA2,QMX2,QX7,RHC,SAR4,SMW2,SM12,SSK1,SSK3,SSX2,SSX4,SXS4 SX7,VED1,VED6,VEX7,VX7,WD12,WKD6,WKT2,WKT4,WKT6,WME2	
			(1)	-	-	(1)	ARL,HTF2,HT2,HT24,HX,HXU,HX2,HX26,HX4,QJG2,QLL,QX,QXBR,QXS2 QXU,QX2,QX26,QX4,SWX2,SWX4,TX,TXBR,TX2,TX26,TX4,WMA4	
			-	(1)	-	-		

Ref. No.	Part No.	Description	Reqd. QTY				Serial No.	Parts catalogue code
			(1)	(2)	(3)	(4)		
10	18381-ZH8-800	GASKET, MUFFLER	1	-	-	-	-----	DS,HHQ4,HTF2,HT2,HT24,HX,HXU,HX2,HX26,HX4,LAJ,LAJ4,LD,LH,LHQ4,LJ,LJC,LJC8,LJD2,LJS,LSJ,LSJ4,LTJ,LTJ1,LTR,LTS,LX,LXU,LX2,LX4,PX,PX2,QA,QA2,QB26,QD,QH,QHQ4,QH26,QJG2,QLL,QM,QMA4,QME4,QMX2,QT,QX,QXS2,QXU,QX2,QX26,QX4,QX7,RD,RD4,RHC,RHQ4,RX,RX4,SAJ,SAJ4,SAR4,SCJ,SD,SD16,SD4,SH,SHQ4,SJ,SJC1,SJC5,SKR,SMJ,SMW2,SM11,SM12,SM14,SSK1,SSK3,SSX2,SSX4,STP,STS,SWX2,SWX4,SX,SXS4,SX4,SX7,TX,TX2,TX26,TX4,UXU,VED,VED1,VED6,VEK,VET,VEX,VEX7,VX,VXU,VX4,VX7,WDA6,WD12,WJ,WJP,WKD6,WKT2,WKT4,WKT6,WMA3,WMA4,WME2,WME4,WMK,WM1
			-	(1)	1	1		
11	18431-ZH8-W50	DEFLECTOR, MUFFLER	(1)	-	-	-	-----	QLL,QMA4,SXS4,VEX,VEX7,WDA6,WD12,WJP,WMA3,WMA4,WME4,WMK,WM1
12	18433-ZH8-W40	COVER COMP., MUFFLER	(1)	-	-	-	-----	HHQ4,HT24,HX4,LAJ4,LHQ4,LSJ4,LX4,QHQ4,QLL,QMA4,QME4,QX4,QX7,RD4,RHQ4,RX4,SAJ4,SAR4,SD4,SHQ4,SWX2,SXS4,SX4,SX7,TX4,VEX,VEX7,VX4,VX7,WDA6,WD12,WKT4,WMA3,WMA4,WMK,WM1
13	18434-ZH8-W40	COVER COMP., MUFFLER RR.	(1)	-	-	-	-----	HHQ4,HT24,HX4,LAJ4,LHQ4,LSJ4,LX4,QHQ4,QLL,QMA4,QME4,QX4,QX7,RD4,RHQ4,RX4,SAJ4,SAR4,SD4,SHQ4,SWX2,SXS4,SX4,SX7,TX4,VEX,VEX7,VX4,VX7,WDA6,WD12,WKT4,WMA3,WMA4,WMK,WM1
14	18436-ZH8-W40	BASE COMP., MUFFLER COVER ...	(1)	-	-	-	-----	HHQ4,HT24,HX4,LAJ4,LHQ4,LSJ4,LX4,QHQ4,QLL,QMA4,QME4,QX4,QX7,RD4,RHQ4,RX4,SAJ4,SAR4,SD4,SHQ4,SWX2,SXS4,SX4,SX7,TX4,VEX,VEX7,VX4,VX7,WDA6,WD12,WKT4,WMA3,WMA4,WMK,WM1
15	18466-ZH8-W40	SPACER, MUFFLER COVER	(3)	-	-	-	-----	HHQ4,HT24,HX4,LAJ4,LHQ4,LSJ4,LX4,QHQ4,QLL,QMA4,QME4,QX4,QX7,RD4,RHQ4,RX4,SAJ4,SAR4,SD4,SHQ4,SXS4,SX4,SX7,TX4,VEX,VEX7,VX4,VX7,WDA6,WD12,WKT4,WMA3,WMA4,WMK,WM1
			(3)	-	-	-	4453887 -----	SWX2
16	18522-ZE1-000	GUIDE, MUFFLER	1	-	-	-	-----	HTF2,LAJ,LAJ4,LJD2,LJS,LSJ,LSJ4,LTJ,LTJ1,LTR,QA,QA2,QLL,QMA4,QMX2,QT,SAJ,SAJ4,SAR4,SCJ,SJC1,SJC5,SKR,SMW2,SM11,SM12,SM14,SSK1,SSK3,SSX2,SSX4,STP,STS,SXS4,VEX,VEX7
17	90002-ZG0-003	SCREW, TAPPING, 4X8	2	-	-	-	-----	HTF2,LAJ,LAJ4,LJD2,LJS,LSJ,LSJ4,LTJ,LTJ1,LTR,QA,QA2,QLL,QMA4,QMX2,QT,SAJ,SAJ4,SAR4,SCJ,SJC1,SJC5,SKR,SMW2,SM11,SM12,SM14,SSK1,SSK3,SSX2,SSX4,STP,STS,SWX2,SWX4,SXS4,VEX,VEX7
18	90016-ZE1-000	BOLT, FLANGE, 6X13(CT200) ...	1	-	-	-	-----	SM11,SM12,SM14
19	90050-ZE1-000	SCREW, TAPPING, 5X8	4	-	-	-	-----	DS,HHQ4,HTF2,HT2,HT24,HX,HXU,HX2,HX26,HX4,LAJ,LAJ4,LD,LH,LHQ4,LJ,LJC,LJC8,LJD2,LJS,LSJ,LSJ4,LTJ,LTJ1,LTR,LTS,LX,LXU,LX2,LX4,PX,PX2,QA,QA2,QD,QH,QHQ4,QH26,QJG2,QLL,QM,QMA4,QME4,QMX2,QT,QX,QXS2,QXU,QX2,QX26,QX4,QX7,RD,RD4,RHC,RHQ4,RX,RX4,SAJ,SAJ4,SAR4,SCJ,SD,SD16,SD4,SH,SHQ4,SJ,SJC1,SJC5,SKR,SMJ,SMW2,SM11,SM12,SM14,SSK1,SSK3,SSX2,SSX4,STP,STS,SWX2,SWX4,SX,SXS4,SX4,SX7,TX,TX2,TX26,TX4,UXU,VED,VED1,VED6,VEK,VET,VEX,VEX7,VX,VXU,VX4,VX7,WDA6,WD12,WJ,WJP,WKD6,WKT2,WKT4,WKT6,WMA3,WMA4,WME2,WME4,WMK,WM1
20	90050-ZE1-000	SCREW, TAPPING, 5X8	-	(4)	4	4		
			(1)	-	-	-	-----	HHQ4,HT24,HX4,LAJ4,LHQ4,LSJ4,LX4,QHQ4,QLL,QMA4,QME4,QX4,QX7,RD4,RHQ4,RX4,SAJ4,SAR4,SD4,SHQ4,SWX2,SXS4,SX4,SX7,TX4,VEX,VEX7,VX4,VX7,WDA6,WD12,WKT4,WMA3,WMA4,WMK,WM1
21	90050-ZH8-W40	SCREW, TAPPING, 5X25	(2)	-	-	-	-----	HHQ4,HT24,HX4,LAJ4,LHQ4,LSJ4,LX4,QHQ4,QLL,QMA4,QME4,QX4,QX7,RD4,RHQ4,RX4,SAJ4,SAR4,SD4,SHQ4,SXS4,SX4,SX7,TX4,VEX,VEX7,VX4,VX7,WDA6,WD12,WKT4,WMA3,WMA4,WMK,WM1
22	90055-ZE1-000	SCREW, TAPPING, 4X6	1	-	-	-	-----	QA,QA2,QMX2,QX7,RHC,SAR4,SMW2,SM12,SSK1,SSK3,SSX2,SSX4,SXS4,SX7,VED1,VED6,VEX7,VX7,WD12,WKD6,WKT2,WKT4,WKT6,WME2
			(1)	-	-	(1)	-----	ARL,HTF2,HT2,HT24,HX,HXU,HX2,HX26,HX4,QJG2,QLL,QX,QXBR,QXS2,QXU,QX2,QX26,QX4,SWX2,SWX4,TX,TXBR,TX2,TX26,TX4,WMA4
			-	(1)	-	-		



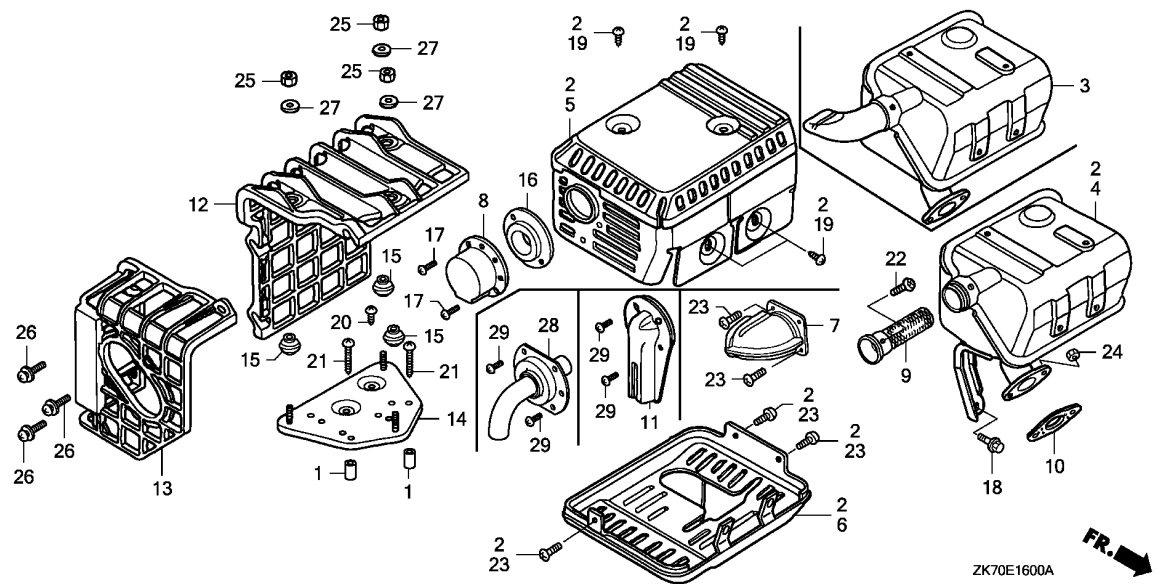

Ref. No.	Part No.	Description	Reqd. QTY				Serial No.	Parts catalogue code
			(1)	(2)	(3)	(4)		
23	90055-ZE1-000	SCREW, TAPPING, 4X6	3	-	-	-	DS, LAJ, LJ, LJC, LJC8, LJS, LSJ, LTJ, LTK1, LTR, LTS, QXS2, SAJ, SCJ, SJ, SJC1, SJC5, SKR, SMJ, VET, WJ, WJP	
24	90136-MT4-000	NUT, FLANGE, 8MM	5	-	-	-	VEK	
	94001-08000-0S	NUT, HEX., 8MM	2	-	-	-	STP, STS	
25	90302-KF9-900	NUT, HEX., 5MM	-	2	2	2	DS, HHQ4, HTF2, HT2, HT24, HX, HXU, HX2, HX26, HX4, LAJ, LAJ4, LD, LH, LHQ4, LJ, LJC, LJC8, LJD2, LJS, LSJ, LSJ4, LTJ, LTK1, LTR, LTS, LX, LXU, LX2, LX4, PX, PX2, QA, QA2, QB26, QD, QH, QHQ4, QH26, QJG2, QLL, QM, QMA4, QME4, QMX2, QT, QX, QXS2, QXU, QX2, QX26, QX4, QX7, RD, RD4, RHC, RHQ4, RX, RX4, SAJ, SAJ4, SAR4, SCJ, SD, SD16, SD4, SH, SHQ4, SJ, SJC1, SJC5, SKR, SMJ, SMM2, SM11, SM12, SM14, SSK1, SSK3, SSS2, SSS4, SWX2, SWX4, SX, SXS4, SX4, SX7, TX, TX2, TX26, TX4, UXU, VED, VED1, VED6, VEK, VET, VEX, VEX7, VX, VXU, VX4, VX7, WDA6, WD12, WJ, WJP, WKD6, WKT2, WKT4, WKT6, WMA3, WMA4, WME2, WME4, WMK, WM1	
26	93891-06020-07	SCREW-WASHER, 6X20	(3)	-	-	-	HHQ4, HT24, HX4, LAJ4, LHQ4, LSJ4, LX4, QHQ4, QLL, QMA4, QME4, QX4, QX7, RD4, RHQ4, RX4, SAJ4, SAR4, SD4, SHQ4, SWX2, SXS4, SX4, SX7, TX4, VEX, VEX7, VX4, VX7, WDA6, WD12, WKT4, WMA3, WMA4, WMK, WM1	
27	94103-05700	WASHER, PLAIN, 5MM	(3)	-	-	-	HHQ4, HT24, HX4, LAJ4, LHQ4, LSJ4, LX4, QHQ4, QLL, QMA4, QME4, QX4, QX7, RD4, RHQ4, RX4, SAJ4, SAR4, SD4, SHQ4, SWX2, SXS4, SX4, SX7, TX4, VEX, VEX7, VX4, VX7, WDA6, WD12, WKT4, WMA3, WMA4, WMK, WM1	
28	18340-ZH7-U20	DEFLECTOR COMP.	1	-	-	-	QJG2	
29	90055-ZE1-000	SCREW, TAPPING, 4X6	2	-	-	-	QJG2	
			(2)	-	-	-	QLL, QMA4, SXS4, VEX, VEX7, WDA6, WD12, WJP, WMA3, WMA4, WME4, WMK, WM1	

E-16-1

MUFFLER(2)

H16

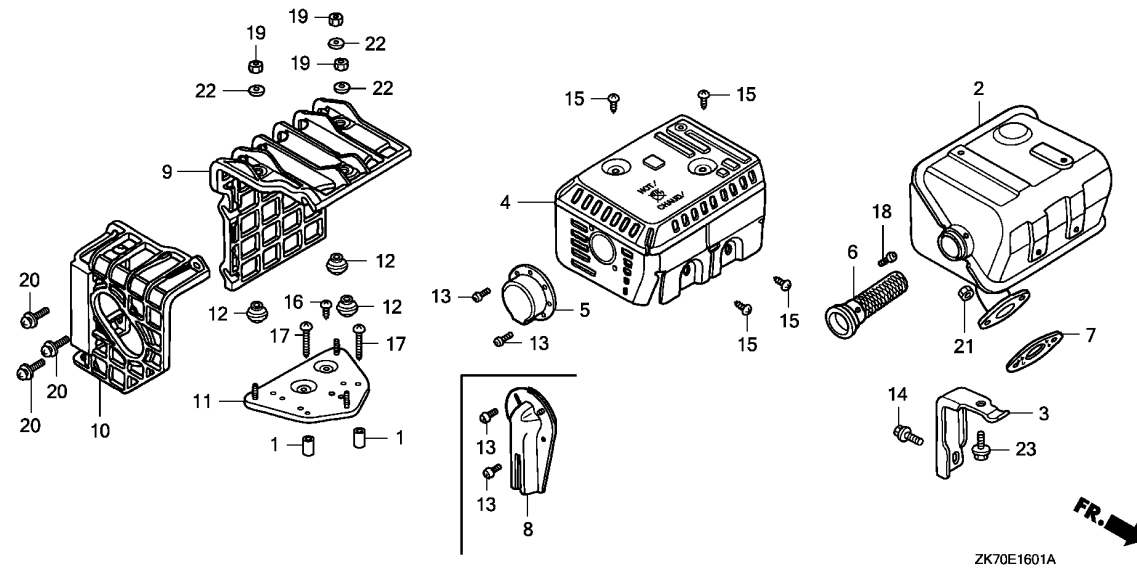

Ref. No.	L.O.N.	(Relative ref. Number) Description	F.R.T.
2	3131C5	MUFFLER, EXHAUST	0.2
4	3131D9	PROTECTOR, EXHAUST MUFFLER : OUTER	0.2
6	3131A1	ARRESTER, SPARK	0.2
		.INCLUDES: Spark arrester check	
7	3131B4	GASKET, EXHAUST MUFFLER	0.2
9	3131A7	COVER, EXHAUST MUFFLER	0.1
10	3131A6	COVER, EXHAUST MUFFLER : REAR ..	0.1
11	3131A2	BASE, EXHAUST MUFFLER COVER ..	0.2

Ref. No.	Part No.	Description	Reqd. QTY				Serial No.	Parts catalogue code
			(1)	GX120K1 (2)	(3)	(4)		
1	17233-896-701	COLLAR, AIR CLEANER CASE	(2)	-	-	-	QMA8,QWA4,SE,SG24,SMA7,VMS4	
2	18310-ZE1-821	MUFFLER COMP. (SILENT)	1	-	-	-	QMA8,QWA4,QXC9,SE,SG24,SJD2,SMA7,VEE1,VMS4,VSX,VSX1	
3	18315-ZE1-000	STAY, MUFFLER	1	(1)	-	-	QMA8,QWA4,QXC9,SE,SG24,SJD2,SMA7,VEE1,VMS4,VSX,VSX1	
4	18320-ZF1-H51	PROTECTOR, MUFFLER (SILENT) ..	1	(1)	-	-	QMA8,QWA4,QXC9,SE,SG24,SJD2,SMA7,VEE1,VMS4,VSX,VSX1	
5	18331-883-810	CAP, MUFFLER	1	(1)	-	-	QMA8,QWA4,QXC9,SG24,SJD2,SMA7,VMS4	
6	18355-ZE1-810	ARRESTER, SPARK (SILENT)	1	(1)	-	-	QMA8,QWA4,QXC9,SE,SG24,SJD2,SMA7,VEE1,VMS4	
7	18381-ZH8-800	GASKET, MUFFLER	1	(1)	-	-	QMA8,QWA4,QXC9,SE,SG24,SJD2,SMA7,VEE1,VMS4,VSX,VSX1	
8	18431-ZH8-W50	DEFLECTOR, MUFFLER	(1)	-	-	-	QMA8,QWA4,SG24,SMA7,VMS4	
9	18433-ZH8-W40	COVER COMP., MUFFLER	(1)	-	-	-	QMA8,QWA4,SE,SG24,SMA7,VMS4	
10	18434-ZH8-W40	COVER COMP., MUFFLER RR.	(1)	-	-	-	QMA8,QWA4,SE,SG24,SMA7,VMS4	
11	18436-ZH8-W40	BASE COMP., MUFFLER COVER ...	(1)	-	-	-	QMA8,QWA4,SE,SG24,SMA7,VMS4	
12	18466-ZH8-W40	SPACER, MUFFLER COVER	(3)	-	-	-	QMA8,QWA4,SE,SG24,SMA7,VMS4	
13	90002-ZG0-003	SCREW, TAPPING, 4X8	-	(2)	-	-		
	90055-ZE1-000	SCREW, TAPPING, 4X6	2	-	-	-	QMA8,QWA4,QXC9,SG24,SJD2,SMA7,VMS4	
14	90016-ZE1-000	BOLT, FLANGE, 6X13(CT200) ...	1	(1)	-	-	QMA8,QWA4,QXC9,SE,SG24,SJD2,SMA7,VEE1,VMS4,VSX,VSX1	
15	90050-ZE1-000	SCREW, TAPPING, 5X8	4	(4)	-	-	QMA8,QWA4,QXC9,SE,SG24,SJD2,SMA7,VEE1,VMS4	
	90050-ZE3-H00	4	-	-	-	VSX,VSX1	
16	90050-ZE1-000	SCREW, TAPPING, 5X8	(1)	-	-	-	QMA8,QWA4,SE,SG24,SMA7,VMS4	



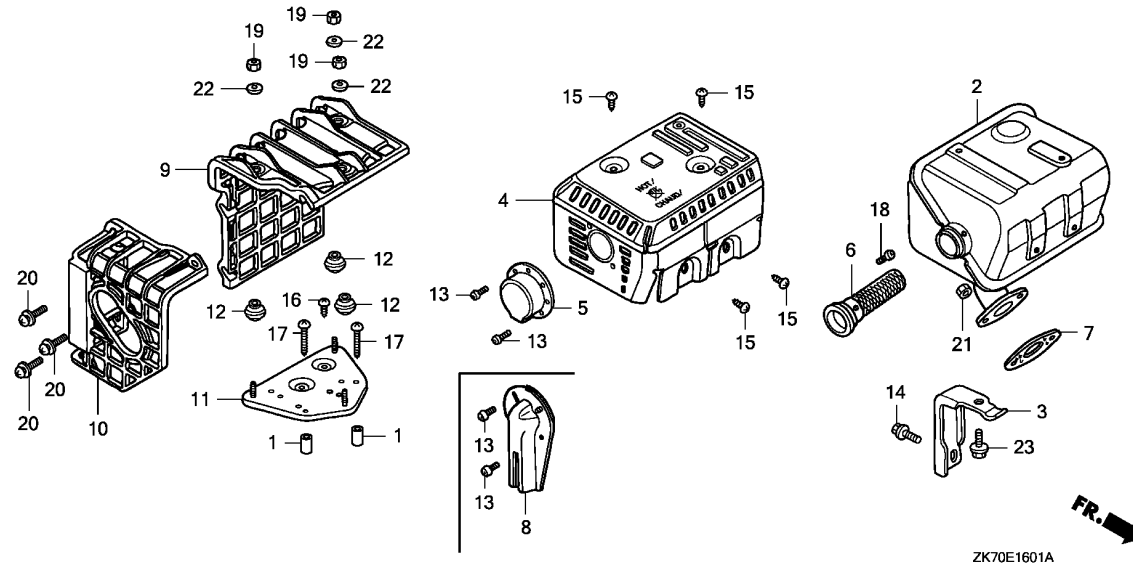

Ref. No.	Part No.	Description	Reqd. QTY				Serial No.	Parts catalogue code
			(1)	GX120K1 (2)	(3)	(4)		
17	90050-ZH8-W40	SCREW, TAPPING, 5X25	(2)	-	-	-	QMA8,QWA4,SE,SG24,SMA7,VMS4	
18	90056-ZL0-000	SCREW, TAPPING, 4X6	1	-	-	-	QMA8,QWA4,QXC9,SE,SG24,SJD2,SMA7,VEE1,VMS4	
19	90302-KF9-900	NUT, HEX., 5MM	-	(1)	-	-	QMA8,QWA4,SE,SG24,SMA7,VMS4	
20	93891-06020-07	SCREW-WASHER, 6X20	(3)	-	-	-	QMA8,QWA4,SE,SG24,SMA7,VMS4	
21	94001-08000-0S	NUT, HEX., 8MM	2	-	-	-	QMA8,QWA4,QXC9,SE,SG24,SJD2,SMA7,VEE1,VMS4,VSX,VSX1	
22	94103-05700	WASHER, PLAIN, 5MM	-	2	-	-	QMA8,QWA4,SE,SG24,SMA7,VMS4	
23	95701-06012-00	BOLT, FLANGE, 6X12	(3)	-	-	-	QMA8,QWA4,QXC9,SE,SG24,SJD2,SMA7,VEE1,VMS4,VSX,VSX1	
			-	(1)	-	-		

E-16-2

MUFFLER(3)

12

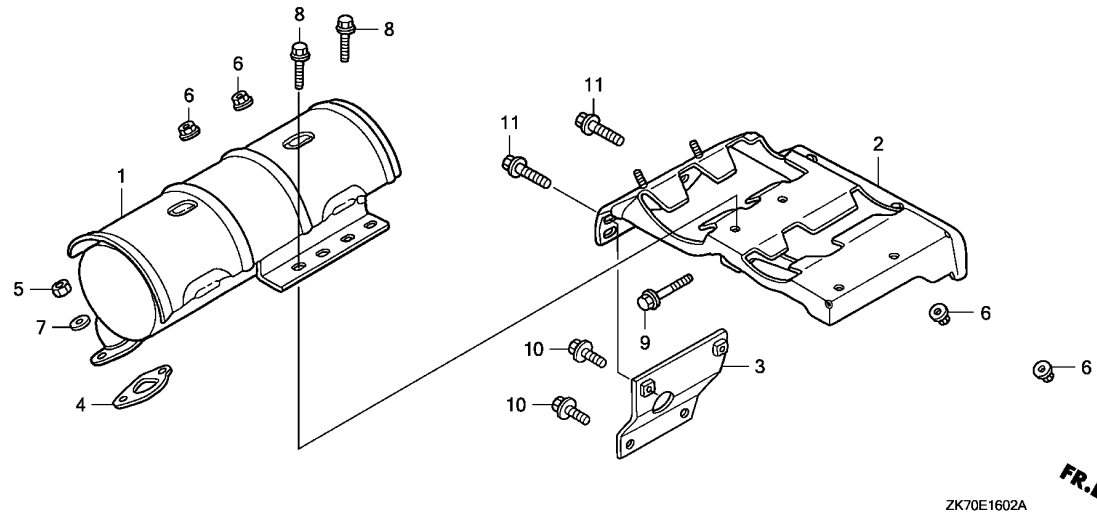

Ref. No.	L.O.N.	(Relative ref. Number) Description	F.R.T.
1	3131C5	MUFFLER, EXHAUST	0.2
2	3131E1	STAY, MUFFLER	0.3
4	3131B4	GASKET, EXHAUST MUFFLER	0.2

Ref. No.	Part No.	Description	Reqd. QTY				Serial No.	Parts catalogue code
			(1)	GX120K1 (2)	(3)	(4)		
1	18310-ZK7-V01	MUFFLER COMP.	1	-	-	-	AR, ARL, DKR, KR, KRA4, KRF4, KRS4, KRS5, KRS6, KRT, KRT4, KRT6	
2	18338-ZK7-V01	STAY COMP., MUFFLER	1	-	-	-	AR, ARL, DKR, KR, KRA4, KRF4, KRS4, KRS5, KRS6, KRT, KRT4, KRT6	
3	18338-ZK7-V20	STAY COMP., MUFFLER	1	-	-	-	KRT, KRT4, KRT6	
4	18381-ZH8-800	GASKET, MUFFLER	1	-	-	-	AR, ARL, DKR, KR, KRA4, KRF4, KRS4, KRS5, KRS6, KRT, KRT4, KRT6	
5	94001-08000-0S	NUT, HEX., 8MM	2	-	-	-	AR, ARL, DKR, KR, KRA4, KRF4, KRS4, KRS5, KRS6, KRT, KRT4, KRT6	
6	94050-06000	NUT, FLANGE, 6MM	4	-	-	-	AR, ARL, DKR, KR, KRA4, KRF4, KRS4, KRS5, KRS6, KRT, KRT4, KRT6	
7	94103-08700	WASHER, PLAIN, 8MM	2	-	-	-	KRF4, KRS4, KRS5, KRS6	
8	95701-06016-00	BOLT, FLANGE, 6X16	2	-	-	-	AR, ARL, DKR, KR, KRA4, KRF4, KRS4, KRS5, KRS6, KRT, KRT4, KRT6	
9	95701-06025-00	BOLT, FLANGE, 6X25	1	-	-	-	AR, ARL, DKR, KR, KRA4, KRF4, KRS4, KRS5, KRS6, KRT, KRT4, KRT6	
10	95701-08012-00	BOLT, FLANGE, 8X12	2	-	-	-	KRT, KRT4, KRT6	
11	95701-08018-00	BOLT, FLANGE, 8X18	2	-	-	-	KRT, KRT4, KRT6	
	95701-08020-00	BOLT, FLANGE, 8X20	2	-	-	-	AR, ARL, DKR, KR, KRA4, KRF4, KRS4, KRS5, KRS6	

2

E-16-3

MUFFLER(4)

13

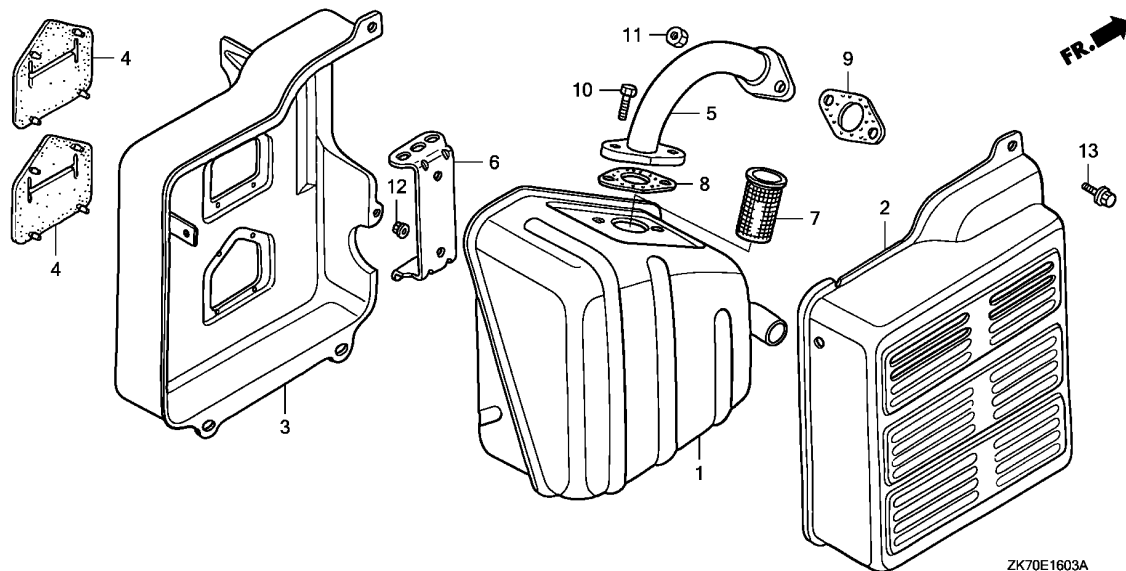

Ref. No.	L.O.N.	(Relative ref. Number) Description	F.R.T.
1	3131C5	MUFFLER, EXHAUST	0.2
2	3131D9	PROTECTOR, EXHAUST MUFFLER : OUTER	0.2
3	3131D8	PROTECTOR, EXHAUST MUFFLER : INNER	0.2
4	3131G6	SEAL, MUFFLER PROTECTORNOTE: Same time for two units	0.2
5	3131C9	PIPE, EXHAUST	0.2
7	3131A1	ARRESTER, SPARK	0.2
		.INCLUDES: Spark arrester check	
8	3131B4	GASKET, EXHAUST MUFFLER	0.2
9	3131B4	GASKET, EXHAUST MUFFLER	0.2

ZK70E1603A

Ref. No.	Part No.	Description	Reqd. QTY				Serial No.	Parts catalogue code
			(1)	GX120K1 (2)	(3)	(4)		
1	18310-ZB3-C00	MUFFLER COMP.	1	-	-	-	VMT ,VPR4	
2	18320-ZB2-000	PROTECTOR, MUFFLER OUTER	1	-	-	-	VMT	
3	18325-ZB2-000	PROTECTOR, MUFFLER INNER	1	-	-	-	VMT	
4	18329-ZB2-000	SEAL, MUFFLER PROTECTOR	2	-	-	-	VMT	
5	18330-ZB2-000	PIPE COMP., EX.	1	-	-	-	VMT	
6	18338-ZB3-E30	STAY, MUFFLER	1	-	-	-	VMT	
7	18355-898-630	ARRESTER, SPARK	1	-	-	-	VPR4	
8	18381-ZE1-800	GASKET, MUFFLER	1	-	-	-	VMT ,VPR4	
9	18381-ZH8-800	GASKET, MUFFLER	1	-	-	-	VMT ,VPR4	
10	92101-08020-0A	BOLT, HEX., 8X20	2	-	-	-	VMT ,VPR4	
11	94001-08000-0S	NUT, HEX., 8MM	2	-	-	-	VMT ,VPR4	
12	94050-06000	NUT, FLANGE, 6MM	2	-	-	-	VMT	
13	95701-06012-00	BOLT, FLANGE, 6X12	5	-	-	-	VMT	

2

E-17

FUEL TANK(1)

14

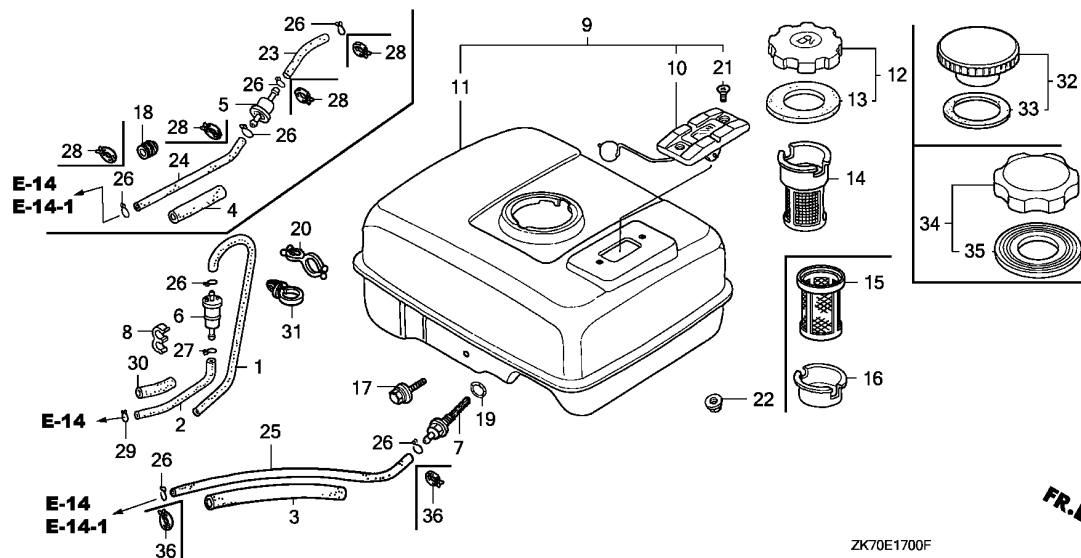

Ref. No.	L.O.N.	(Relative ref. Number) Description	F.R.T.
2	3101G0	TUBE, FUEL STRAINER (5)	0.1
6	3101H8	STRAINER, FUEL (19)	0.1
7	3101H6	JOINT, FUEL STRAINER	0.2
10	6171A1	METER/GAUGE UNIT, FUEL (9)	0.1
11	3101H7	TANK, FUEL (15)	0.2
14	3101A6	FILTER, FUEL	0.1
25	3101F1	TUBE, FUEL TANK	0.2

Ref. No.	Part No.	Description	Reqd. QTY				Serial No.	Parts catalogue code
			(1)	GX120K1 (2)	(3)	(4)		
1	16198-ZG0-U00	TUBE A, AIR VENT	1	-	-	-	AR,ARL,DKR,KR,KRA4,KRF4,KRS4,KRS5,KRS6,KRT,KRT4,KRT6	
2	16199-KCR-000	TUBE	1	-	-	-	AR,ARL,DKR,KR,KRA4,KRF4,KRS4,KRT,KRT4,KRT6	
	16199-ZK7-S50		1	-	-	-	KRS5,KRS6	
3	16854-ZH8-000	RUBBER, SUPPORTER (107MM)	1	-	-	-	DS,HHQ4,HTF2,HT2,HT24,HX,HXU,HX2,HX26,HX4,LAJ,LAJ4,LH,LHQ4,LJ,LJC,LJC8,LJD2,LJS,LSJ,LTJ,LTK1,LX,LXU,LX2,LX4,PX,PX2,QA,QA2,QH,QHQ4,QH26,QJG2,QLL,QMA4,QMA8,QME4,QMX2,QT,QWA4,QX,QXC9,QXS2,QXU,QX2,QX26,QX4,QX7,RHQ4,RX,RX4,SAJ,SAJ4,SAR4,SCJ,SD4,SG24,SH,SHQ4,SJ,SJC1,SJC5,SJD2,SMA7,SMJ,SMW2,SM11,SM12,SM14,SSK1,SSK3,SSX2,SSX4,STP,STS,SWX2,SWX4,SX,SXS4,SX4,SX7,SYA,TX,TX2,TX26,TX4,UXU,VED,VED1,VED6,VEE1,VEK,VET,VEX,VEX7,VMS4,VSX,VSX1,VX,VXU,VX4,VX7,WDA6,WD12,WJ,WJP,WKD6,WKT2,WKT4,WKT6,WMA3,WMA4,WME2,WMK	
4	16854-ZH8-000	RUBBER, SUPPORTER (107MM)	1	-	(1)	1	4411475 KRS5,KRS6	
	16854-ZH8-810	RUBBER, SUPPORTER (50MM)	1	-	-	-	KRS4,VPM4,VPR4	
	35376-ZV5-830	TUBE, POWER TRIM-TILT SWITCH CORD (50MM)	1	-	-	-	4411476 KRS5,KRS6	
5	16910-GB2-005	STRAINER COMP., FUEL	1	-	-	-	KRS4,KRS5,KRS6,VPM4,VPR4	
6	16910-ZG0-U02	STRAINER COMP., FUEL	1	-	-	-	AR,ARL,DKR,KR,KRA4,KRF4,KRS4,KRS5,KRS6,KRT,KRT4,KRT6	



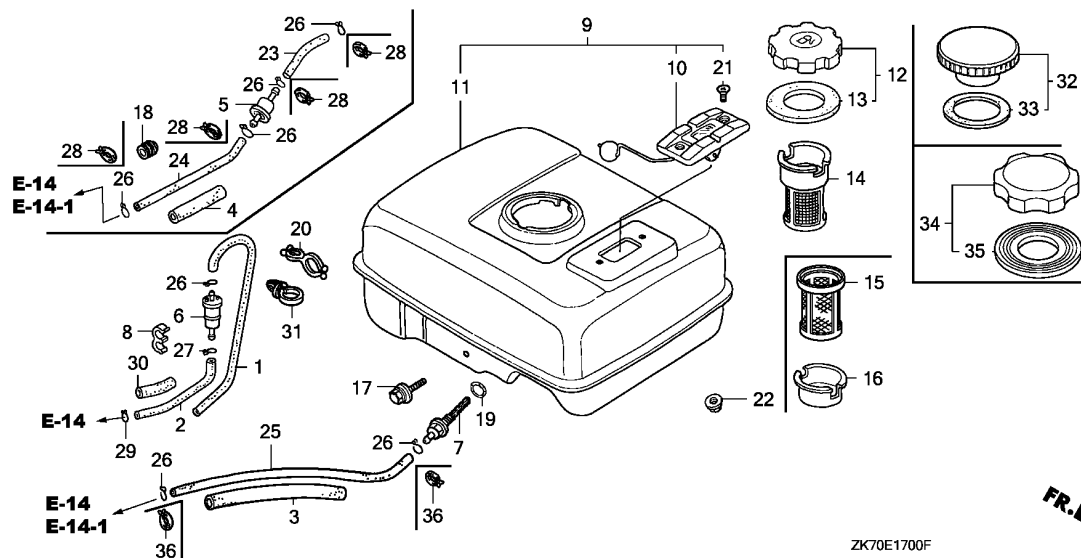

Ref. No.	Part No.	Description	Reqd. QTY				Serial No.	Parts catalogue code
			(1)	(2)	(3)	(4)		
7	16955-ZE1-000	JOINT, FUEL TANK	1	-	-	-	DS,HHQ4,HTF2,HT2,HT24,HX,HXU,HX2,HX26,HX4,LAJ,LAJ4,LD,LH,LHQ4,LJ,LJC,LJC8,LJD2,LJS,LSJ,LSJ4,LTJ,LTK1,LX,LXU,LX2,LX4,PX,PX2,QA,QA2,QD,QH,QHQ4,QH26,QJG2,QLL,QM,QMA4,QMA8,QME4,QMX2,QT,QWA4,QX,QXC9,QXS2,QXU,QX2,QX26,QX4,QX7,RD,RD4,RHQ4,RX,RX4,SAJ,SAJ4,SAR4,SCJ,SD,SD16,SD4,SE,SG24,SH,SHQ4,SJ,SJC1,SJC5,SJD2,SKR,SMA7,SMJ,SMW2,SM11,SM12,SM14,SSK1,SSK3,SSX2,SSX4,STP,STS,SWX2,SWX4,SX,SXS4, SX4, SX7, TX, TX2, TX26, TX4, UXU, VED, VED1, VED6, VEE1, VEK, VET, VEX, VEX7, VMS4, VSX, VSX1, VX, VXU, VX4, VX7, WDA6, WD12, WJ, WJP, WKD6, WKT2, WKT4, WKT6, WMA3, WMA4, WME2, WME4, WMK	
8	17205-PC6-000	CLAMP, TUBE, 7.5X2	1	-	-	-	AR,ARL,DKR,KR,KRA4,KRS4,KRS5,KRS6,KRT,KRT4,KRT6	
9	17500-ZE1-813ZA	TANK ASSY., FUEL (GAUGE) *NH31*.....MCKINLEY WHITE	1	-	-	-	SKR	
10	17505-ZE1-013	GAUGE ASSY., FUEL	1	-	-	-	SKR	
	17505-ZH7-A21	1	-	-	-	SMJ,VEK	
11	17510-ZE0-020ZA	TANK COMP., FUEL *NH31*.....MCKINLEY WHITE	1	-	-	-	DS,HHQ4,HTF2,HT2,HX,HXU,HX2,HX26,HX4,LAJ,LAJ4,LD,LH,LHQ4,LJ,LJC,LJC8,LJS,LSJ,LSJ4,LTJ,LTK1,LX,LXU,LX2,LX4,PX,QA,QA2,QD,QH,QHQ4,QH26,QLL,QM,QMA4,QMA8,QME4,QMX2,QT,QX,QXC9,QXS2,QXU,QX2,QX26,QX4,QX7,RD,RD4,RHQ4,RX,RX4,SAJ,SAJ4,SAR4,SCJ,SD,SD16,SD4,SE,SH,SHQ4,SJ,SJC1,SJC5,SMA7,SMW2,STP,STS,SX,SXS4, SX4, SX7, TX, TX2, TX26, TX4, UXU, VED, VED1, VED6, VET, VEX, VEX7, VMS4, VSX, VSX1, VX, VXU, VX4, VX7, WDA6, WD12, WJ, WJP, WKD6, WKT2, WKT4, WKT6, WMA3, WMA4, WME2, WME4, WMK	
	17510-ZE0-020ZD	*NH1*.....BLACK	1	-	-	-	HT24, HX2, PX2, QMX2, QWA4, QXC9, QXS2, QXU, QX2, SG24, SM11, SM12, SM14, SSK1, SSK3, SSX2, SSX4, TX4, VED, VSX, VSX1	

Ref. No.	Part No.	Description	Reqd. QTY				Serial No.	Parts catalogue code
			(1)	(2)	(3)	(4)		
11)	17510-ZE0-020ZG	TANK COMP., FUEL *NH105*...MAT BLACK (#15-#20)	1	-	-	-	-----	SWX2,SWX4
	17510-ZE0-020ZK	*T73*.....EXEN GRAY	1	-	-	-	-----	VEE1
	17510-ZE0-020ZL	*R280*.....POWER RED	1	-	-	-	-----	VSX1
	17510-ZH7-A20ZD	*NH31*.....MCKINLEY WHITE	1	-	-	-	-----	SMJ,VEK
	17510-ZK7-U20ZA	*NH105*...MAT BLACK (#15-#20)	1	-	-	-	-----	LJD2,QJG2,SJD2
	17510-ZK7-U20ZB	*T51*.....JACOBSEN ORANGE	1	-	-	-	-----	QJG2
12	17620-ZH7-023	CAP COMP., FUEL FILLER (BLACK)	-	-	-	1		
13	17631-ZH7-003	PACKING, FUEL FILLER CAP (39X58X3)	-	-	-	1		
14	17670-ZH7-A81	FILTER COMP., FUEL	1	-	-	-	-----	VEK
	17672-ZE2-W01	FILTER, FUEL	1	-	-	-	-----	DS,LAJ,LAJ4,LJ,LJS,LSJ,LSJ4,LTJ,LTK1,QA,QA2,QLL,QMX2,QT,SAJ SAJ4,SAR4,SCJ,SJ,SKR,SMJ,SMW2,SM11,SM12,SM14,SSK1,SSK3,SSX2 SSX4,STP,STS,VED,VED1,VED6,VEK,VET,VSX,VSX1,WDA6,WJ,WJP,WKD6 WKT2,WKT4,WKT6,WME2
			-	(1)	1	-		
15	17672-880-000	FILTER, FUEL	1	-	1	-	-----	LJC,LJC8,SJC1,SJC5,WIH
	17672-887-791	1	-	-	-	-----	VEE1
16	17673-893-000	HOLDER, FUEL FILTER	1	-	1	-	-----	LJC,LJC8,SJC1,SJC5,VEE1,WIH
17	90004-ZH7-003	BOLT, FLANGE, 6X29	1	-	1	1	-----	DS,HHQ4,HTF2,HT2,HT24,HX,HXU,HX2,HX26,HX4,LAJ,LAJ4,LD,LH,LHQ4 LJ,LJC,LJC8,LJD2,LJS,LSJ,LSJ4,LTJ,LTK1,LX,LXU,LX2,LX4,PX,PX2 QA,QA2,QD,QH,QHQ4,QH26,QJG2,QLL,QM,QMA4,QMA8,QME4,QMX2,QT,QWA4 QX,QXC9,QXS2,QXU,QX2,QX26,QX4,QX7,RD,RD4,RHQ4,RX,RX4,SAJ,SAJ4 SAR4,SCJ,SD,SD16,SD4,SE,SG24,SH,SHQ4,SJ,SJC1,SJC5,SJD2,SMA7 SMJ,SMW2,SM11,SM12,SM14,SSK1,SSK3,SSX2,SSX4,STP,STS,SWX2,SWX4 SX,SXS4,SX4,SX7,TX,TXBR,TX2,TX26,TX4,UXU,VED,VED1,VED6,VEE1 VEK,VET,VEX,VEX7,VMS4,VSX,VSX1,VX,VXBR,VXU,VX4,VX7,WDA6,WD12 WIH,WIS,WJ,WJP,WKD6,WKT2,WKT4,WKT6,WMA3,WMA4,WME2,WME4,WMK
	95701-06025-00	BOLT, FLANGE, 6X25	-	(1)	-	-		
	95900-06025-00	-	-	1	-	-----	QDBR,QXBR
	95900-06025-00	-	-	1	-	-----	SIH
18	90854-ZB3-000	RUBBER, FUEL (9X15X20)	1	-	-	-	-----	VPM4,VPR4
19	91353-671-004	O-RING, 14MM(NOK)	1	-	-	-	-----	DS,HHQ4,HTF2,HT2,HT24,HX,HXU,HX2,HX26,HX4,LAJ,LAJ4,LD,LH,LHQ4 LJ,LJC,LJC8,LJD2,LJS,LSJ,LSJ4,LTJ,LTK1,LX,LXU,LX2,LX4,PX,PX2 QA,QA2,QD,QH,QHQ4,QH26,QJG2,QLL,QM,QMA4,QMA8,QME4,QMX2,QT,QWA4 QX,QXC9,QXS2,QXU,QX2,QX26,QX4,QX7,RD,RD4,RHQ4,RX,RX4,SAJ,SAJ4 SAR4,SCJ,SD,SD16,SD4,SE,SG24,SH,SHQ4,SJ,SJC1,SJC5,SJD2,SKR SMA7,SMJ,SMW2,SM11,SM12,SM14,SSK1,SSK3,SSX2,SSX4,STP,STS,SWX2 SWX4,SX,SXS4,SX4,SX7,TX,TX2,TX26,TX4,UXU,VED,VED1,VED6,VEE1 VEK,VET,VEX,VEX7,VMS4,VSX,VSX1,VX,VXU,VX4,VX7,WDA6,WD12,WJ,WJP WKD6,WKT2,WKT4,WKT6,WMA3,WMA4,WME2,WME4,WMK
			-	(1)	1	1		
20	91473-PA1-003	CLIP, WATER HOSE	1	-	-	-	-----	AR,ARL,DKR,KRA4,KRT4
21	93600-05010-0A	SCREW, FLAT, 5X10	2	-	-	-	-----	SKR,SMJ,VEK
22	94050-06000	NUT, FLANGE, 6MM	2	-	-	-	-----	DS,HHQ4,HTF2,HT2,HT24,HX,HXU,HX2,HX26,HX4,LAJ,LAJ4,LD,LH,LHQ4 LJ,LJC,LJC8,LJD2,LJS,LSJ,LSJ4,LTJ,LTK1,LX,LXU,LX2,LX4,PX,PX2 QA,QA2,QD,QH,QHQ4,QH26,QJG2,QLL,QM,QMA4,QMA8,QME4,QMX2,QT,QWA4 QX,QXC9,QXS2,QXU,QX2,QX26,QX4,QX7,RD,RD4,RHQ4,RX,RX4,SAJ,SAJ4 SAR4,SCJ,SD,SD16,SD4,SE,SG24,SH,SHQ4,SJ,SJC1,SJC5,SJD2,SMA7 SMJ,SMW2,SM11,SM12,SM14,SSK1,SSK3,SSX2,SSX4,STP,STS,SWX2,SWX4 SX,SXS4,SX4,SX7,TX,TX2,TX26,TX4,UXU,VED,VED1,VED6,VEE1,VEK,VET VEX,VEX7,VMS4,VSX,VSX1,VX,VXU,VX4,VX7,WDA6,WD12,WJ,WJP,WKD6 WKT2,WKT4,WKT6,WMA3,WMA4,WME2,WME4,WMK
			-	(2)	2	2		
23	95001-45035-40	TUBE, FUEL, 4.5X35 (95001-45001-60M)	1	-	-	-	-----	VPM4,VPR4

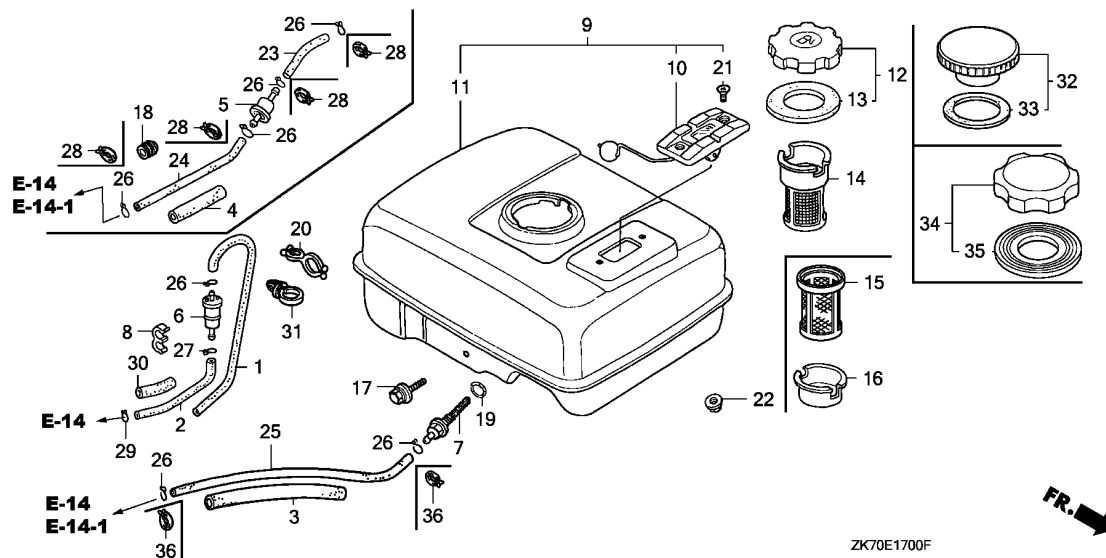

Ref. No.	Part No.	Description	Reqd. QTY				Serial No.	Parts catalogue code
			(1)	GX120K1 (2)	(3)	(4)		
23)	95001-45075-60	TUBE, FUEL, 4.5X75 (95001-45001-60M)	1	-	-	-	4411475	KRS5,KRS6
	95001-45350-60	TUBE, FUEL, 4.5X350 (95001-45001-60M)	1	-	-	-	4411476	KRS4 KRS5,KRS6
24	95001-45075-60	TUBE, FUEL, 4.5X75 (95001-45001-60M)	1	-	-	-	4411476	KRS4 KRS5,KRS6
	95001-45110-40	TUBE, FUEL, 4.5X110 (95001-45001-60M)	1	-	-	-		VPM4,VPR4
	95001-45350-60	TUBE, FUEL, 4.5X350 (95001-45001-60M)	1	-	-	-	4411475	KRS5,KRS6
25	95001-45140-40	TUBE, FUEL, 4.5X140 (95001-45001-60M)	1	-	-	-		DS,HHQ4,HTF2,HT2,HT24,HX,HXU,HX2,HX26,HX4,LAJ,LAJ4,LD,LH,LHQ4 LJ,LJC,LJC8,LJD2,LJS,LSJ,LSJ4,LTJ,LTK1,LX,LXU,LX2,LX4,PX,PX2 QA,QA2,QD,QH,QHQ4,QH26,QJG2,QLL,QM,QMA4,QMA8,QME4,QMX2,QT,QWA4 QX,QXC9,QXS2,QXU,QX2,QX26,QX4,QX7,RD,RD4,RHQ4,RX,RX4,SAJ,SAJ4 SAR4,SCJ,SD,SD16,SD4,SE,SG24,SH,SHQ4,SJ,SJC1,SJC5,SJD2,SMA7 SMJ,SMW2,SM11,SM12,SM14,SSK1,SSK3,SSX2,SSX4,STP,STS,SWX2,SWX4 SX,SXS4,SX4,SX7,TX,TX2,TX26,TX4,UXU,VED,VED1,VED6,VEE1,VEK,VET VEX,VEX7,VMS4,VSX,VSX1,VX,VXU,VX4,VX7,WDA6,WD12,WJ,WJP,WKD6 WKT2,WKT4,WKT6,WMA3,WME2,WME4,WMK
	95001-45750-40	TUBE, FUEL, 4.5X750 (95001-45001-60M)	-	(1)	1	1		SKR
	17512-ZK7-S90	TUBE, FUEL	1	-	-	-	4586084	SYA
	17512-ZK7-S91	1	-	-	-	4586085	SYA
	91424-Z4F-801	TUBE, FUEL, 4.5X140(FKM)	1	-	-	-		WMA4

Ref. No.	Part No.	Description	Reqd. QTY				Serial No.	Parts catalogue code
			(1)	(2)	(3)	(4)		
26	95002-02080	CLIP, TUBE (B8)	1	-	-	-	AR, ARL, DKR, KR, KRA4, KRF4, KRS4, KRS5, KRS6, KRT, KRT4, KRT6, SYA	
			2	-	-	-	DS, HHQ4, HTF2, HT2, HT24, HX, HXU, HX2, HX26, HX4, LAJ, LAJ4, LD, LH, LHQ4	
							LJ, LJC, LJC8, LJD2, LJS, LSJ, LSJ4, LTJ, LTK1, LX, LXU, LX2, LX4, PX, PX2	
							QA, QA2, QD, QH, QHQ4, QH26, QJG2, QLL, QM, QMA4, QMA8, QME4, QMX2, QT, QWA4	
							QX, QXC9, QXS2, QXU, QX2, QX26, QX4, QX7, RD, RD4, RHQ4, RX, RX4, SAJ, SAJ4	
							SAR4, SCJ, SD, SD16, SD4, SE, SG24, SH, SHQ4, SJ, SJC1, SJC5, SJD2, SKR	
							SMA7, SMJ, SMW2, SM11, SM12, SM14, SSK1, SSK3, SXS2, SXS4, STP, STS, SWX2	
							SWX4, SX, SXS4, SX4, SX7, TX, TX2, TX26, TX4, UXU, VED, VED1, VED6, VEE1	
							VEK, VET, VEX, VEX7, VMS4, VSX, VSX1, VX, VXU, VX4, VX7, WDA6, WD12, WJ, WJP	
							WKD6, WKT2, WKT4, WKT6, WMA3, WME2, WME4, WMK	
			4	-	-	-	VPM4, VPR4	
			-	(2)	2	2		
27	95002-02100	CLIP, TUBE (B10)	1	-	-	-	AR, ARL, DKR, KR, KRA4, KRF4, KRS4, KRS5, KRS6, KRT, KRT4, KRT6	
28	95002-40800-08	CLAMP, TUBE (D8)	4	-	-	-	KRS4, KRS5, KRS6	
29	95002-50000	CLIP, TUBE (C9)	1	-	-	-	AR, ARL, DKR, KR, KRA4, KRF4, KRS4, KRS5, KRS6, KRT, KRT4, KRT6	
30	16854-ZH8-810	RUBBER, SUPPORTER (50MM)	1	-	-	-	4411475 KRS5, KRS6	
	35376-ZV5-830	TUBE, POWER TRIM-TILT SWITCH CORD (50MM)	1	-	-	-	4411476 KRS5, KRS6	
31	90617-SAO-003	CLIP, WIRE HARNESS	1	-	-	-	KRS5, KRS6	
32	17620-ZE2-W00	CAP COMP., FUEL FILLER (CHROME PLATED)	-	-	1	-		
33	17631-329-003	PACKING, FUEL FILLER CAP (39X58X3)	-	-	1	-		
34	17620-ZOT-305	CAP COMP., FUEL FILLER (CHROME PLATED)	1	-	-	-	DS, HHQ4, HTF2, HT2, HT24, HX, HXU, HX2, HX26, HX4, LAJ, LAJ4, LD, LH, LHQ4	
							LJ, LJC, LJC8, LJD2, LJS, LSJ, LSJ4, LTJ, LTK1, LX, LXU, LX2, LX4, PX, PX2	
							QA, QA2, QD, QH, QHQ4, QH26, QJG2, QLL, QM, QMA4, QMA8, QME4, QMX2, QT, QWA4	
							QX, QXC9, QXS2, QXU, QX2, QX26, QX4, QX7, RD, RD4, RHQ4, RX, RX4, SAJ, SAJ4	
							SAR4, SCJ, SD, SD16, SD4, SE, SG24, SH, SHQ4, SJ, SJC1, SJC5, SJD2, SKR	
							SMA7, SMJ, SMW2, SM11, SM12, SM14, SSK1, SSK3, SXS2, SXS4, STP, STS, SWX2	
							SWX4, SX, SXS4, SX4, SX7, TX, TX2, TX26, TX4, UXU, VED, VED1, VED6, VEE1	
							VEK, VET, VEX, VEX7, VMS4, VSX, VSX1, VX, VXU, VX4, VX7, WDA6, WD12, WJ, WJP	
							WKD6, WKT2, WKT4, WKT6, WMA3, WMA4, WME2, WME4, WMK	
			-	(1)	1	1		
35	17631-ZOT-812	PACKING, FUEL FILLER CAP (39X62X3)	1	-	-	-	DS, HHQ4, HTF2, HT2, HT24, HX, HXU, HX2, HX26, HX4, LAJ, LAJ4, LD, LH, LHQ4	
							LJ, LJC, LJC8, LJD2, LJS, LSJ, LSJ4, LTJ, LTK1, LX, LXU, LX2, LX4, PX, PX2	
							QA, QA2, QD, QH, QHQ4, QH26, QJG2, QLL, QM, QMA4, QMA8, QME4, QMX2, QT, QWA4	
							QX, QXC9, QXS2, QXU, QX2, QX26, QX4, QX7, RD, RD4, RHQ4, RX, RX4, SAJ, SAJ4	
							SAR4, SCJ, SD, SD16, SD4, SE, SG24, SH, SHQ4, SJ, SJC1, SJC5, SJD2, SKR	
							SMA7, SMJ, SMW2, SM11, SM12, SM14, SSK1, SSK3, SXS2, SXS4, STP, STS, SWX2	
							SWX4, SX, SXS4, SX4, SX7, TX, TX2, TX26, TX4, UXU, VED, VED1, VED6, VEE1	
							VEK, VET, VEX, VEX7, VMS4, VSX, VSX1, VX, VXU, VX4, VX7, WDA6, WD12, WJ, WJP	
							WKD6, WKT2, WKT4, WKT6, WMA3, WMA4, WME2, WME4, WMK	
			-	(1)	1	1		
36	95002-40800-08	CLAMP, TUBE (D8)	2	-	-	-	WMA4	



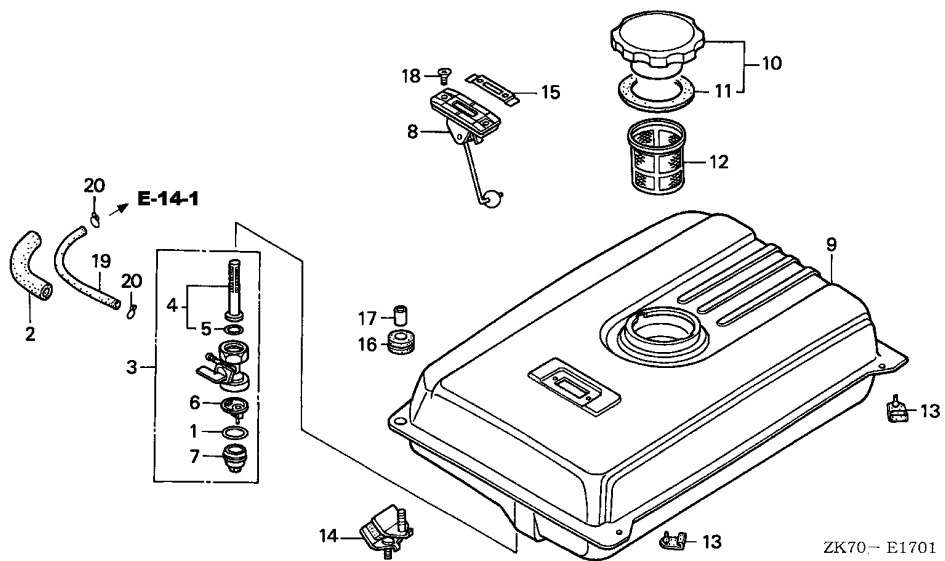

Ref. No.	L.O.N.	(Relative ref. Number) Description	F.R.T.
1		(7)	
3	3101L6	PACKING, FUEL STRAINER CUP ...	0.2
3	3101A3	COCK, FUEL	0.2
4		(5)	
4	3101D5	SCREEN, FUEL STRAINER	0.2
6	3101A7	FILTER, FUEL TANK CUP	0.2
8	6171A1	METER/GAUGE UNIT, FUEL	0.1
9	3101H7	TANK, FUEL	0.2
12	3101A6	FILTER, FUEL	0.1
14	3101D1	RUBBER, TANK MOUNTING	0.1
16	3101M4	RUBBER, TANK SETTING	0.1
19	3101F2	TUBE, FUEL COCK	0.2

Ref. No.	Part No.	Description	Reqd. QTY				Serial No.	Parts catalogue code
			(1)	GX120K1 (2)	(3)	(4)		
1	16173-001-004	PACKING, FUEL STRAINER CUP ..	1	-	-	-	LTR	
2	16854-ZH8-000	RUBBER, SUPPORTER (107MM) ..	1	-	-	-	LTR	
3	16950-ZB4-015	COCK ASSY., FUEL	1	-	-	-	LTR	
4	16952-ZB4-005	SCREEN, FUEL STRAINER	1	-	-	-	LTR	
5	16958-397-771	O-RING	1	-	-	-	LTR	
6	16959-471-831	FILTER, CUP	1	-	-	-	LTR	
7	16967-GA6-671	CUP, FUEL STRAINER	1	-	-	-	LTR	
8	17505-ZB2-003	METER ASSY., FUEL	1	-	-	-	LTR	
9	17510-ZB4-000ZH	TANK COMP., FUEL	1	-	-	-	LTR	
		R280.....POWER RED	1	-	-	-	LTR	
10	17620-899-013	CAP COMP., FUEL FILLER	1	-	-	-	LTR	
11	17631-899-000	PACKING, FUEL FILLER CAP	1	-	-	-	LTR	
12	17670-899-000	FILTER COMP., FUEL	1	-	-	-	LTR	
13	50319-ZB2-000	RUBBER, TANK MOUNTING	2	-	-	-	LTR	
14	68325-899-000	RUBBER, BOTTOM	4	-	-	-	LTR	
15	87565-ZB4-A00	PLATE, FUEL INDICATION	1	-	-	-	LTR	
16	90851-898-000	RUBBER, TANK CUSHION	2	-	-	-	LTR	
17	91551-898-000	COLLAR, TANK CUSHION	2	-	-	-	LTR	
18	93600-05010-0A	SCREW, FLAT, 5X10	2	-	-	-	LTR	
19	95001-45300-40	TUBE, FUEL, 4.5X300	1	-	-	-	LTR	
		(95001-45001-60M)	1	-	-	-	LTR	
20	95002-02080	CLIP, TUBE (B8)	2	-	-	-	LTR	

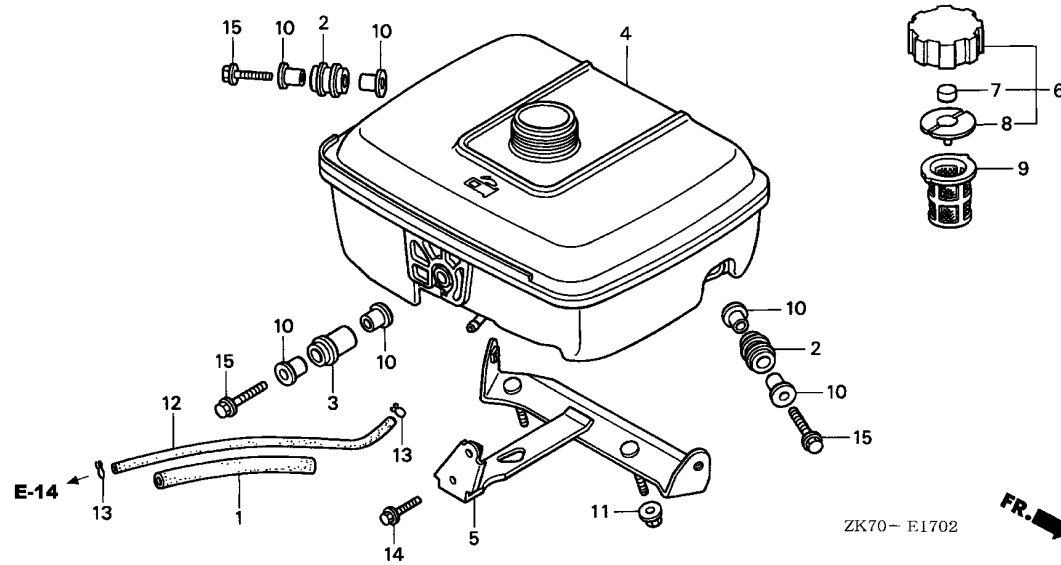

Ref. No.	L.O.N.	(Relative ref. Number) Description	F.R.T.
2	(10)	RUBBER, TANK SETTING(A)	0.1
3	(10)	RUBBER, TANK SETTING(B)	0.1
4	3101H7	TANK, FUEL	0.2
5	3101E0	STAY, FUEL TANK	0.2
9	3101A6	FILTER, FUEL	0.1
12	3101F1	TUBE, FUEL TANK	0.2

Ref. No.	Part No.	Description	Reqd. QTY				Serial No.	Parts catalogue code
			(1)	GX120K1 (2)	(3)	(4)		
1	16854-ZH8-000	RUBBER, SUPPORTER (107MM) ...	1	-	-	-	WM1	
2	17506-ZK7-800	RUBBER, TANK SETTING (A)	2	-	-	-	WM1	
3	17507-ZK7-800	RUBBER, TANK SETTING (B)	1	-	-	-	WM1	
4	17510-ZK7-800	TANK COMP., FUEL	1	-	-	-	WM1	
5	17561-ZK7-800	STAY, FUEL TANK	1	-	-	-	WM1	
6	17620-ZE7-000	CAP ASSY., FUEL TANK	1	-	-	-	WM1	
7	17622-888-010	SPONGE, FUEL CAP BREATHER ...	1	-	-	-	WM1	
8	17624-ZE7-000	PACKING, FUEL CAP	1	-	-	-	WM1	
9	17672-ZK7-800	FILTER, FUEL	(1)	-	-	-	WM1	
10	90509-750-000	COLLAR, FUEL TANK	6	-	-	-	WM1	
11	94050-06000	NUT, FLANGE, 6MM	2	-	-	-	WM1	
12	95001-45140-40	TUBE, FUEL, 4.5X140 (95001-45001-60M)	1	-	-	-	WM1	
13	95002-02080	CLIP, TUBE (B8)	2	-	-	-	WM1	
14	95701-06025-00	BOLT, FLANGE, 6X25	1	-	-	-	WM1	
15	95701-06032-00	BOLT, FLANGE, 6X32	3	-	-	-	WM1	



E-17-3

FUEL TANK(4)

I11

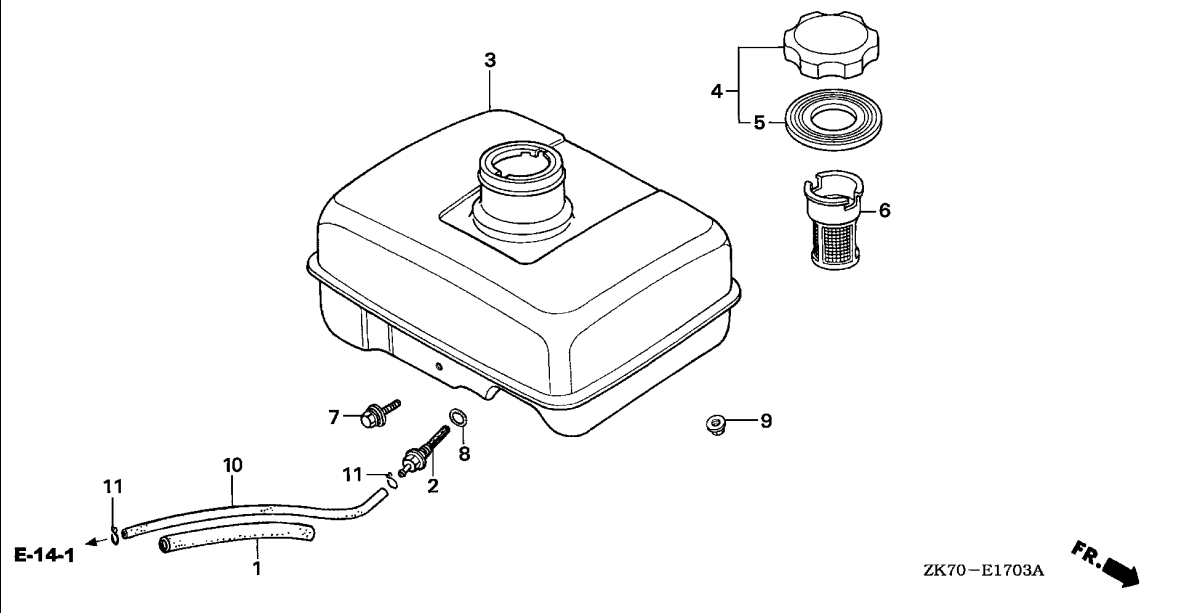

Ref. No.	L.O.N.	(Relative ref. Number) Description	F.R.T.
2	3101H6	(8) JOINT, FUEL STRAINER	0.2
3	3101H7	TANK, FUEL	0.2
6	3101A6	FILTER, FUEL	0.1
10	3101F1	TUBE, FUEL TANK	0.2

Ref. No.	Part No.	Description	Reqd. QTY				Serial No.	Parts catalogue code
			(1)	GX120K1 (2)	(3)	(4)		
1	16854-ZH8-000	RUBBER, SUPPORTER (107MM) ...	1	-	-	-	LTS	
2	16955-ZE1-000	JOINT, FUEL TANK	1	-	-	-	LTS	
3	17510-ZK7-U20ZC	TANK COMP., FUEL *R280*.....POWER RED	1	-	-	-	LTS	
4	17620-Z0T-305	CAP COMP., FUEL FILLER (CHROME PLATED)	1	-	-	-	LTS	
5	17631-Z0T-812	PACKING, FUEL FILLER CAP (39X62X3)	1	-	-	-	LTS	
6	17672-ZE2-W01	FILTER, FUEL	1	-	-	-	LTS	
7	90004-ZH7-003	BOLT, FLANGE, 6X29	1	-	-	-	LTS	
8	91353-671-004	O-RING, 14MM(NOK)	1	-	-	-	LTS	
9	94050-06000	NUT, FLANGE, 6MM	2	-	-	-	LTS	
10	95001-45140-40	TUBE, FUEL, 4.5X140 (95001-45001-60M)	1	-	-	-	LTS	
11	95002-02080	CLIP, TUBE (B8)	2	-	-	-	LTS	

2

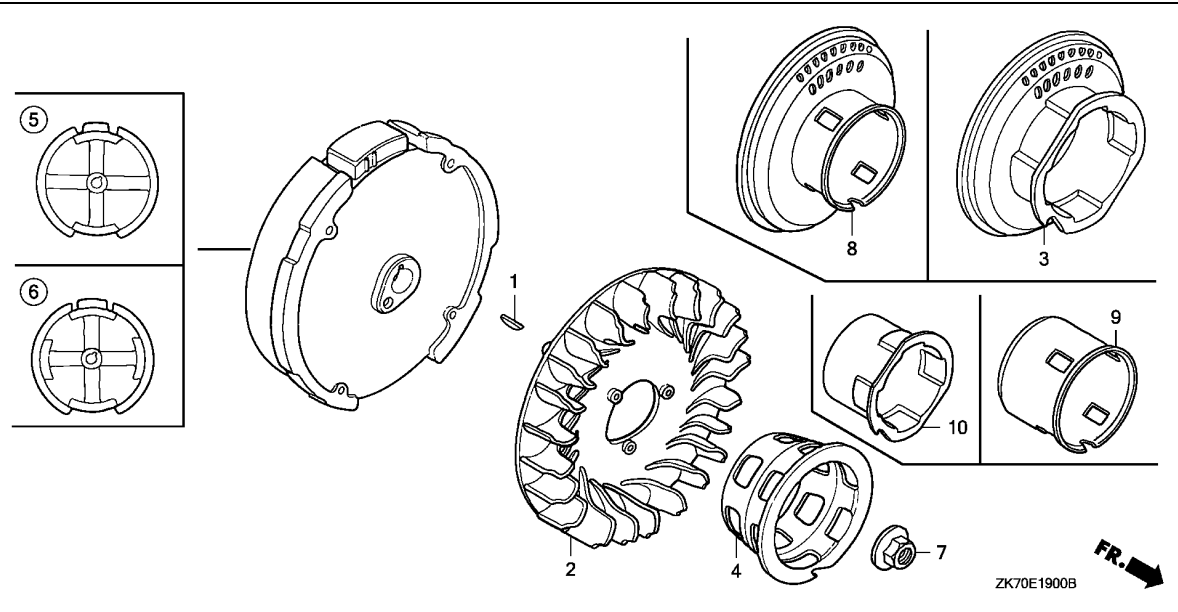

Ref. No.	L.O.N.	(Relative ref. Number) Description	F.R.T.
2	1141G7	FAN, ENGINE COOLING (3,8,9,10)	0.2
4	1121A9	PULLEY, RECOIL STARTER (6)	0.2
5	2161B5	FLYWHEEL	0.3

Ref. No.	Part No.	Description	Reqd. QTY				Serial No.	Parts catalogue code
			(1)	GX120K1 (2)	(3)	(4)		
1	13331-357-000	KEY, SPECIAL WOODRUFF, 25X18	1	1	1	1		
2	19511-ZE0-000	FAN, COOLING	1	-	-	-		AR, ARL, DKR, DS, HHQ4, HTF2, HT2, HT24, HX, HXU, HX2, HX26, HX4, KR, KRA4, KRF4, KRS4, KRS5, KRS6, KRT, KRT4, KRT6, LAJ, LAJ4, LD, LH, LHQ4, LJ, LJC, LJC8, LJD2, LJS, LSJ, LSJ4, LTJ, LTK1, LTR, LTS, LX, LXU, LX2, LX4, PX, PX2, QA, QA2, QB26, QD, QH, QHQ4, QH26, QJG2, QLL, QM, QMA4, QMA8, QME4, QMX2, QT, QWA4, QX, QXC9, QXS2, QXU, QX2, QX26, QX4, QX7, RD, RD4, RHC, RHQ4, RX, RX4, SAJ, SAJ4, SAR4, SCJ, SD, SD16, SD4, SE, SG24, SH, SHQ4, SJ, SJD2, SKR, SMA7, SMJ, SMW2, SM11, SM12, SM14, SSK1, SSK3, SSX2, SSX4, STP, STS, SWX2, SWX4, SX, SXS4, SX4, SX7, SYA, TX, TX2, TX26, TX4, UXU, VED, VED1, VED6, VEE1, VEK, VET, VEX, VEX7, VMS4, VMT, VPM4, VPR4, VSX, VSX1, VX, VXU, VX4, VX7, WDA6, WD12, WJ, WJP, WKD6, WKT2, WKT4, WKT6, WMA3, WMA4, WME2, WME4, WMK, WM1
	19511-ZE1-000	-	1	1	1		SJC1, SJC5
3	28450-ZH7-811	PULLEY COMP., STARTER	1	-	-	-	4363610	LTJ, LTS, QA, QA2, QMA8, QWA4, SE, SG24, SMA7, VEK
4	28451-ZE0-003	PULLEY, STARTER	1	(1)	-	-		QT
5	31100-ZE0-010	FLYWHEEL COMP.	1	-	-	-		AR, DKR, HHQ4, HTF2, HT2, HT24, HXU, HX2, HX26, HX4, KRA4, KRF4, KRS4, KRS5, KRS6, KRT4, LD, LHQ4, LSJ, LSJ4, LXU, LX2, LX4, PX2, QA, QA2, QD, QHQ4, QH26, QLL, QMA4, QMA8, QME4, QMX2, QT, QWA4, QXC9, QXU, QX2, QX26, QX4, QX7, RD, RD4, RHQ4, RX4, SAJ4, SAR4, SD16, SD4, SE, SG24, SH, SHQ4, SMA7, SMW2, SM12, SM14, SSK1, SSX2, SSX4, SWX2, SWX4, SXS4, SX4, SX7, TX, TX2, TX26, TX4, UXU, VED1, VED6, VEE1, VET, VEX, VEX7, VMS4, VPM4, VPR4, VXU, VX4, VX7, WDA6, WD12, WJP, WKD6, WKT2, WKT4, WKT6, WMA3, WME2, WME4, WM1
			1	-	-	-	4554359	ARL, DS, HX, KR, KRT, KRT6, LH, LJ, LJC, LJC8, LTJ, LTK1, LTR, LTS, LX, PX, QH, QM, QX, RX, SAJ, SCJ, SD, SJ, SJC1, SJC5, SKR, SMJ, SM11, SSK3, STP, STS, SX, VED, VEK, VMT, VSX, VSX1, VX, WJ, WMA4, WMK
			-	(1)	-	-	4554359	
			-	-	1	1		



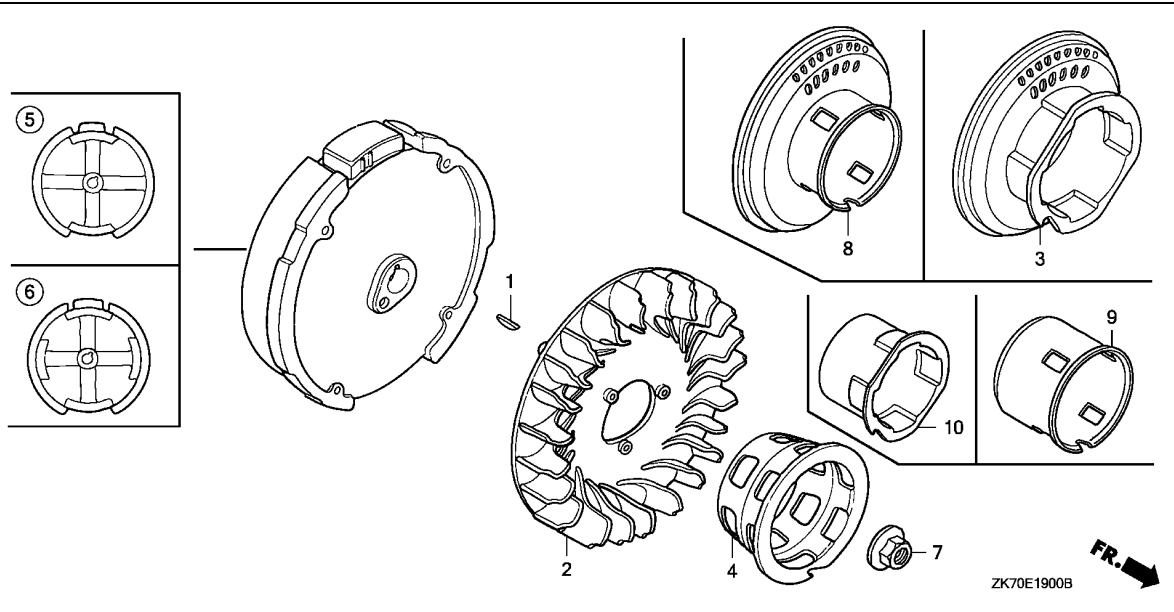

Ref. No.	Part No.	Description	Reqd. QTY				Serial No.	Parts catalogue code
			(1)	GX120K1 (2)	(3)	(4)		
(5)	31100-ZE0-020	FLYWHEEL COMP.	1	-	-	-	4554360	----- ARL,DS,HX,KR,KRT,KRT6,LH,LJ,LJC,LJC8,LTJ, LTK1,LTR,LTS,LX,PX,QH QM,QX,RX,SAJ,SCJ,SD,SJ,SJC1,SJC5,SKR,SMJ,SM11,SSK3,STP,STS,SX VED,VEK,VMT,VSX,VSX1,VX,WJ,WMA4,WMK
			-	(1)	-	-	4554360	
6	31100-ZE0-811	FLYWHEEL COMP. (LAMP)	1	-	-	-	----- LAJ4,LJD2,QJG2,QXS2,RHC,SJD2	
			1	-	-	-	4553617	----- LAJ,LJS,QB26,SYA
	31100-ZE0-812	1	-	-	-	4553618	----- LAJ,LJS,QB26,SYA
			-	(1)	-	-	4553618	
7	90201-878-003	NUT, SPECIAL, 14MM	1	1	1	1		
8	28450-ZH7-801	PULLEY COMP., STARTER	1	-	-	-	4363611	----- LTJ,LTS,QA,QA2,QMA8,QWA4,SE,SG24,SMA7,VEK
			-	(1)	-	-		
9	28451-ZH7-801	PULLEY, STARTER	1	-	-	-	----- ARL,HT24,LJC8,SAR4,SYA,WMA4,WMK	
			1	-	-	-	4363434	----- AR,DKR,DS,HHQ4,HTF2,HT2,HX,HXU,HX2,HX26,HX4,KR,KRA4,KRF4,KRS4 KRS5,KRS6,KRT,KRT4,KRT6,LAJ,LAJ4,LD,LH,LHQ4,LJ,LJC,LJD2,LJS LSJ,LSJ4,LTK1,LTR,LX,LXU,LX2,LX4,PX,PX2,QB26,QD,QH,QHQ4,QH26 QJG2,QLL,QM,QMA4,QME4,QMX2,QX,QXC9,QXS2,QXU,QX2,QX26,QX4,QX7 RD,RD4,RHC,RHQ4,RX,RX4,SAJ,SAJ4,SCJ,SD,SD16,SD4,SH,SHQ4,SJ SJC1,SJC5,SJD2,SKR,SMJ,SMW2,SM11,SM12,SM14,SSK1,SSK3,SSX2,SSX4 STP,STS,SWX2,SWX4,SX,SXS4,SX4,SX7,TX,TX2,TX26,TX4,UXU,VED,VED1 VED6,VEE1,VET,VEK,VEX7,VMS4,VMT,VPM4,VPR4,VSX,VSX1,VX,VXU,VX4 VX7,WDA6,WD12,WJ,WJP,WKD6,WKT2,WKT4,WKT6,WMA3,WME2,WME4,WMI
			-	(1)	1	1		

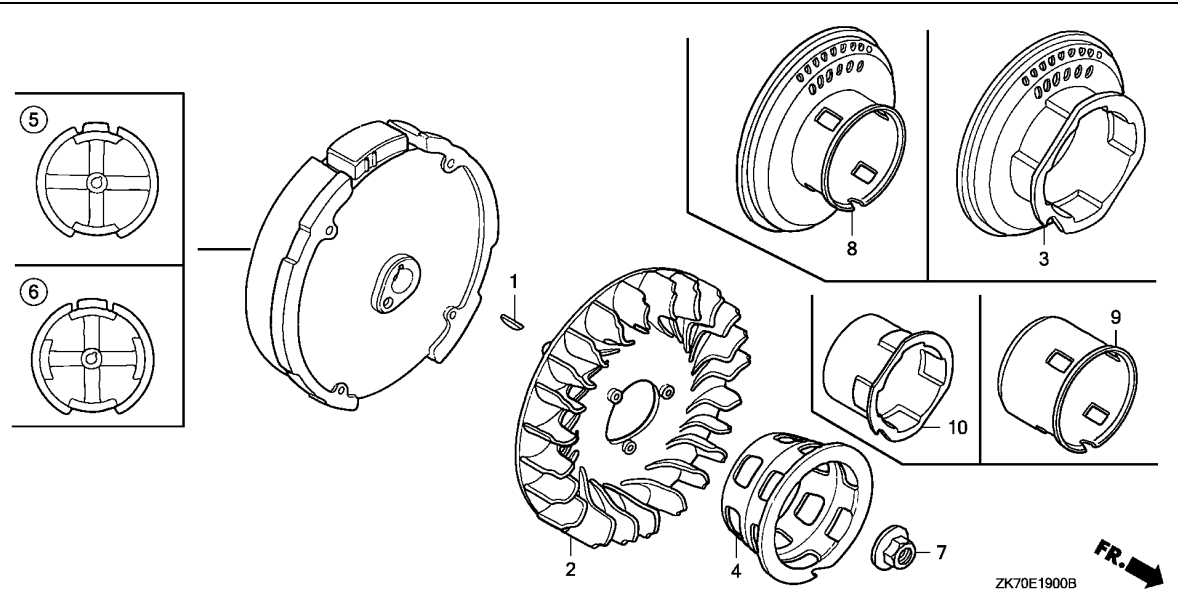

Ref. No.	Part No.	Description	Reqd. QTY				Serial No.	Parts catalogue code
			(1)	GX120K1 (2)	(3)	(4)		
10	28451-ZH7-003	PULLEY, STARTER	1	-	-	-	4363433	AR,DKR,DS,HHQ4,HTF2,HT2,HX,HXU,HX2,HX26,HX4,KR,KRA4,KRF4,KRS4,KRS5,KRS6,KRT,KRT4,KRT6,LAJ,LAJ4,LD,LH,LHQ4,LJ,LJC,LJD2,LJS,LSJ,LSJ4,LTK1,LTR,LX,LXU,LX2,LX4,PX,PX2,QB26,QD,QH,QHQ4,QH26,QJG2,QLL,QM,QMA4,QME4,QMX2,QX,QXC9,QXS2,QXU,QX2,QX26,QX4,QX7,RD,RD4,RHC,RHQ4,RX,RX4,SAJ,SAJ4,SCJ,SD,SD16,SD4,SH,SHQ4,SJ,SJC1,SJC5,SJD2,SKR,SMJ,SMW2,SM11,SM12,SM14,SSK1,SSK3,SSX2,SSX4,STP,STS,SWX2,SWX4,SX,SXS4,SX4,SX7,TX,TX2,TX26,TX4,UXU,VED,VED1,VED6,VEE1,VET,VEX,VEX7,VMS4,VMT,VPM4,VPR4,VSX,VSX1,VX,VXU,VX4,VX7,WDA6,WD12,WJ,WJP,WKD6,WKT2,WKT4,WKT6,WMA3,WME2,WME4,WM1
			-	(1)	1	1		



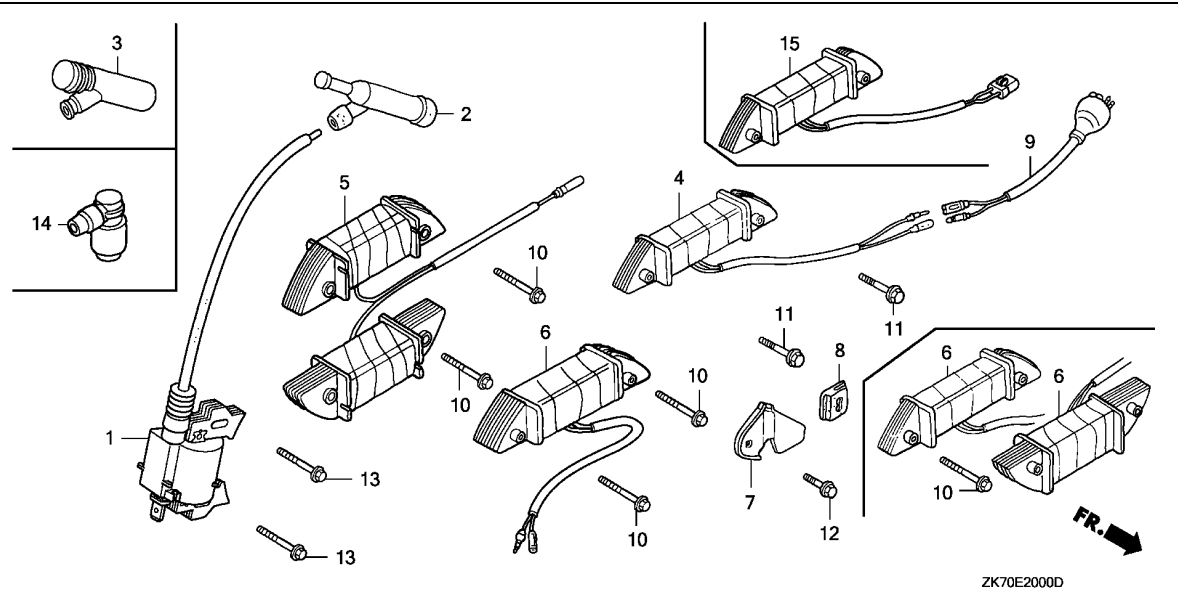

Ref. No.	L.O.N.	(Relative ref. Number) Description	F.R.T.
1	6141A5	COIL, IGNITION(ONE) (3,14)	0.2
2	6141B8	TERMINAL, HIGH TENSION (4,6,15)	0.1
5	6141A6	COIL, LAMP	0.3
9	6141C5	CABLE, DOUBLE CONNECTOR	0.1

ZK70E2000D

Ref. No.	Part No.	Description	Reqd. QTY				Serial No.	Parts catalogue code
			(1)	(2)	(3)	(4)		
1	30500-ZE1-033	COIL ASSY., IGNITION	-	-	1	1	----- TXBR,VXBR,WIS	
	30500-ZE1-043	1	-	-	-	4450768 AR,DKR,DS,HHQ4,HTF2,HT2,HX,HXU,HX2,HX26,HX4,KR,KRA4,KRF4,KRS4,KRS5,KRS6,KRT,KRT4,KRT6,LAJ,LAJ4,LD,LH,LHQ4,LJ,LJC,LJC8,LJD2,LJS,LSJ,LSJ4,LTJ,LTK1,LTR,LTS,LX,LXU,LX2,LX4,PX,PX2,QA,QA2,QB26,QD,QH,QHQ4,QH26,QJG2,QLL,QM,QMA4,QMA8,QME4,QMX2,QT,QWA4,QX,QXC9,QXS2,QXU,QX2,QX26,QX4,QX7,RD,RD4,RHC,RHQ4,RX,RX4,SAJ,SAJ4,SCJ,SD,SD16,SD4,SE,SG24,SH,SHQ4,SJ,SJC1,SJC5,SJD2,SKR,SMA7,SMJ,SMW2,SM11,SM12,SM14,SSK1,SSK3,SSX2,SSX4,STP,STS,SWX2,SWX4,SX,SXS4,SX4,SX7,TX,TX2,TX26,TX4,UXU,VED,VED1,VED6,VEE1,VEK,VET,VEX,VEX7,VMS4,VMT,VPM4,VPR4,VSX,VSX1,VX,VXU,VX4,VX7,WDA6,WD12,WJ,WJP,WKD6,WKT2,WKT4,WKT6,WMA3,WME2,WME4,WM1	
			-	(1)	-	-	4450768 QDBR,QXBR,SIH,WIH	
	30500-ZE1-053	1	-	-	-	4456559 HT24	
			1	-	-	-	4450769 4456559 AR,DKR,DS,HHQ4,HTF2,HT2,HX,HXU,HX2,HX26,HX4,KR,KRA4,KRF4,KRS4,KRS5,KRS6,KRT,KRT4,KRT6,LAJ,LAJ4,LD,LH,LHQ4,LJ,LJC,LJC8,LJD2,LJS,LSJ,LSJ4,LTJ,LTK1,LTR,LTS,LX,LXU,LX2,LX4,PX,PX2,QA,QA2,QB26,QD,QH,QHQ4,QH26,QJG2,QLL,QM,QMA4,QMA8,QME4,QMX2,QT,QWA4,QX,QXC9,QXS2,QXU,QX2,QX26,QX4,QX7,RD,RD4,RHC,RHQ4,RX,RX4,SAJ,SAJ4,SCJ,SD,SD16,SD4,SE,SG24,SH,SHQ4,SJ,SJC1,SJC5,SJD2,SKR,SMA7,SMJ,SMW2,SM11,SM12,SM14,SSK1,SSK3,SSX2,SSX4,STP,STS,SWX2,SWX4,SX,SXS4,SX4,SX7,TX,TX2,TX26,TX4,UXU,VED,VED1,VED6,VEE1,VEK,VET,VEX,VEX7,VMS4,VMT,VPM4,VPR4,VSX,VSX1,VX,VXU,VX4,VX7,WDA6,WD12,WJ,WJP,WKD6,WKT2,WKT4,WKT6,WMA3,WME2,WME4,WM1	
			-	(1)	-	-	4450769 4456559	

2

Ref. No.	Part No.	Description	Reqd. QTY				Serial No.	Parts catalogue code
			(1)	(2)	(3)	(4)		
(1)	30500-ZE1-063	COIL ASSY., IGNITION	1	-	-	-	----- SAR4	
			1	-	-	-	4456560 ----- AR,DKR,HHQ4,HTF2,HT2,HT24,HXU,HX2,HX26,HX4,KRA4,KRF4,KRS4,KRS5	
							KRS6,KRT4,LAJ4,LD,LHQ4,LJD2,LSJ,LSJ4,LXU,LX2,LX4,PX2,QA,QA2,QD	
							QHQ4,QH26,QJG2,QLL,QMA4,QMA8,QME4,QMX2,QT,QWA4,QXC9,QXS2,QXU	
							QX2,QX26,QX4,QX7,RD,RD4,RHC,RHQ4,RX4,SAJ4,SD16,SD4,SE,SG24,SH	
							SHQ4,SJD2,SMA7,SMW2,SM12,SM14,SSK1,SSX2,SSX4,SWX2,SWX4,SXS4	
							SX4,SX7,TX,TX2,TX26,TX4,UXU,VED1,VED6,VEE1,VET,VEX,VEX7,VMS4	
							VPM4,VPR4,VXU,VX4,VX7,WDA6,WD12,WJP,WKD6,WKT2,WKT4,WKT6,WMA3	
							WME2,WME4,WM1	
			1	-	-	-	4569508 ARL,SYA,WMA4,WMK	
			1	-	-	-	4456560 4569508 DS,HX,KR,KRT,KRT6,LAJ,LH,LJ,LJC,LJC8,LJS,LTJ,LTK1,LTR,LTS,LX	
							PX,QB26,QH,QM,QX,RX,SAJ,SCJ,SD,SJ,SJC1,SJC5,SKR,SMJ,SM11,SSK3	
							STP,STS,SX,VED,VEK,VMT,VSX,VSX1,VX,WJ	
	30500-ZE1-073	-	(1)	-	-	4456560 4569508	
			1	-	-	-	4569509 ----- ARL,DS,HX,KR,KRT,KRT6,LAJ,LH,LJ,LJC,LJC8,LJS,LTJ,LTK1,LTR,LTS	
							LX,PX,QB26,QH,QM,QX,RX,SAJ,SCJ,SD,SJ,SJC1,SJC5,SKR,SMJ,SM11	
							SSK3,STP,STS,SX,SYA,VED,VEK,VMT,VSX,VSX1,VX,WJ,WMA4,WMK	
			-	(1)	-	-	4569509	
2	30600-ZE1-013	TERMINAL ASSY., HIGH TENSION (NICHIWA Y-EZ)	1	-	-	-	----- KRT6,LJC,LTK1,QM,QT,STP,STS,VEK,VSX,VSX1	
			-	(1)	1	-		
	30700-ZE1-013	CAP ASSY., NOISE SUPPRESSOR (NICHIWA Y-EZ RTFM256)	1	-	-	-	----- AR,ARL,DKR,DS,HHQ4,HTF2,HT2,HT24,HX,HXU,HX2,HX26,HX4,KR,KRA4	
							KRF4,KRT,KRT4,LAJ,LAJ4,LD,LH,LHQ4,LJ,LJC8,LJD2,LJS,LSJ,LSJ4	
							LTJ,LTR,LTS,LX,LXU,LX2,LX4,PX,PX2,QA,QA2,QB26,QD,QH,QHQ4,QH26	
							QJG2,QLL,QMA4,QMA8,QME4,QMX2,QWA4,QX,QXC9,QXS2,QXU,QX2,QX26	
							QX4,QX7,RD,RD4,RHC,RHQ4,RX,RX4,SAJ,SAJ4,SAR4,SCJ,SD,SD16,SD4	
							SE,SG24,SH,SHQ4,SJ,SJC1,SJC5,SJD2,SKR,SMA7,SMJ,SMW2,SM11,SM12	
							SM14,SSK1,SSK3,SSX2,SSX4,SWX2,SWX4,SX,SXS4,SX4,SX7,SYA,TX,TX2	
							TX26,TX4,UXU,VED,VED1,VED6,VEE1,VET,VEX,VEX7,VMS4,VMT,VX,VXU	
							VX4,VX7,WDA6,WD12,WJ,WJP,WKD6,WKT2,WKT4,WKT6,WMA3,WMA4,WME2	
							WME4,WMK,WM1	
			-	(1)	-	1		
	30700-ZF5-013	CAP ASSY., NOISE SUPPRESSOR	1	-	-	-	----- VPM4,VPR4	
3	30700-ZE8-003	CAP ASSY., NOISE SUPPRESSOR	1	-	-	-	----- KRS4	
4	31510-ZE1-003	COIL ASSY., LAMP (12V/15W) ..	-	(1)	-	-		
	31510-ZE1-821	COIL ASSY., LAMP (6V/15W) ...	-	(1)	-	-		
	31610-ZH7-003	COIL ASSY., LAMP (12V/15W) ..	-	(1)	-	-		
5	31510-ZE1-711	COIL ASSY., LAMP (12V/50W) ..	1	-	-	-	----- QJG2,QXS2,RHC	
			-	(1)	-	-		
	31510-ZK7-U50	1	-	-	-	----- QB26	
6	31510-ZE1-811	COIL ASSY., LAMP (12V/25W) ..	1	-	-	-	----- LAJ,LAJ4	
			2	-	-	-	----- LJS	
			-	(1)	-	-		
	31510-ZE1-831	COIL ASSY., LAMP (6V/25W) ...	-	(1)	-	-		
7	31511-ZE1-000	CLAMPER, CORD	1	-	-	-	----- LAJ,LAJ4,LJS,QB26,QJG2,QXS2,RHC,SYA	
			-	(1)	-	-		
8	31512-ZE1-000	GROMMET, CORD	1	-	-	-	----- LAJ,LAJ4,LJS,QB26,QJG2,QXS2,RHC,SYA	
			-	(1)	-	-		
9	32105-ZE1-000	CABLE, DOUBLE CONNECTOR	-	(1)	-	-		
10	90015-883-000	BOLT, FLANGE, 6X28	2	-	-	-	----- LAJ,LAJ4	
			4	-	-	-	----- LJS,QB26,QJG2,QXS2,RHC	
			-	(4)	-	-		
11	90018-ZE1-000	BOLT, FLANGE, 6X23(CT200) ...	2	-	-	-	----- SYA	
			-	(2)	-	-		



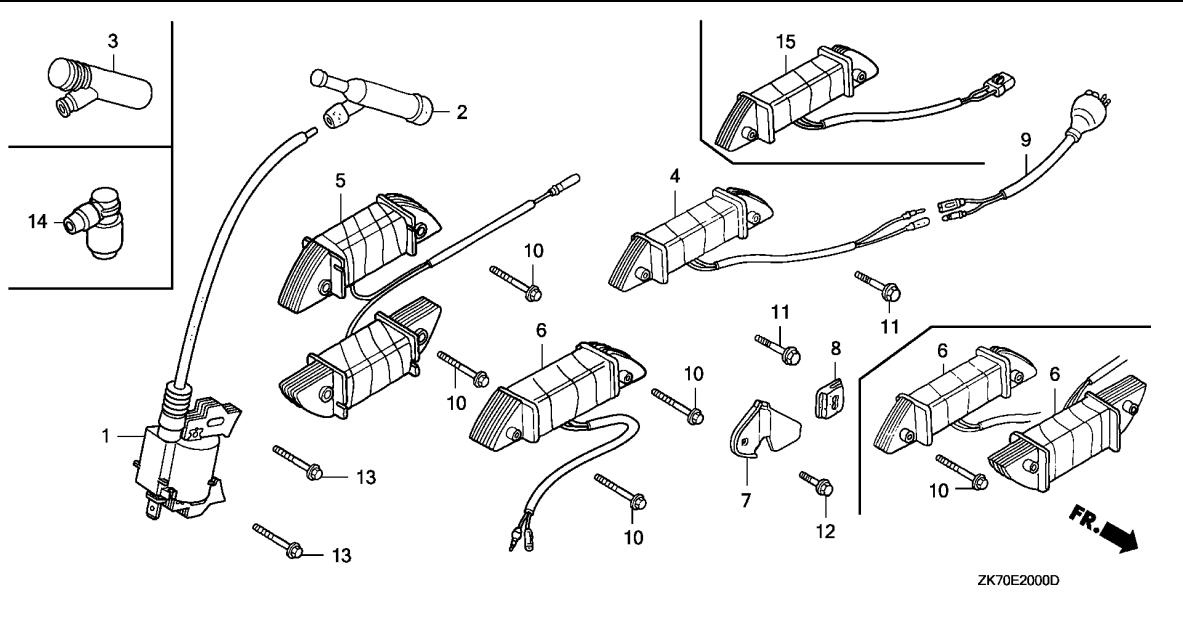

Ref. No.	Part No.	Description	Reqd. QTY				Serial No.	Parts catalogue code
			(1)	GX120K1 (2)	(3)	(4)		
12	90019-883-000	BOLT, FLANGE, 5X10	1	-	-	-	----- LAJ, LAJ4, LJS, QB26, QJG2, QXS2, RHC, SYA	
13	90121-952-000	BOLT, FLANGE, 6X25(CT200) ...	-	(1)	-	-		
14	30700-ZJ1-841	CAP ASSY., NOISE SUPPRESSOR .	2	2	2	2	----- KRS5, KRS6	
15	31510-ZK7-S91	COIL ASSY., LAMP (12V-15W) ..	1	-	-	-	----- SYA	

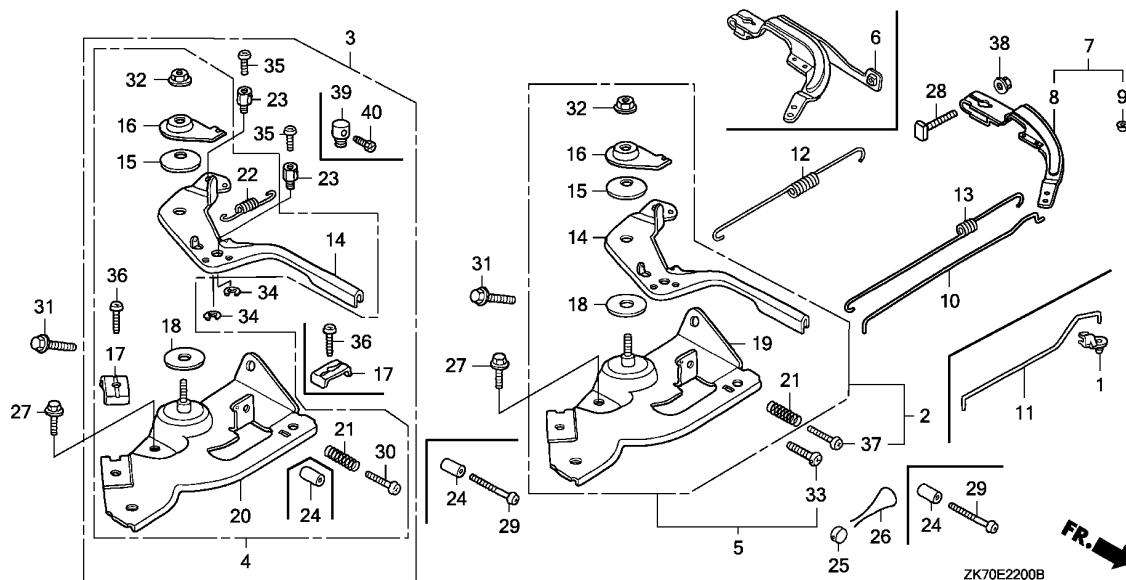

Ref. No.	L.O.N.	(Relative ref. Number) Description	F.R.T.
2		(3,5) CONTROL, THROTTLE/GOVERNOR ...	0.2
8		(6,7) ARM, GOVERNOR	0.3
10		(11) ROD, GOVERNOR	0.3
12		1161C5 SPRING, GOVERNOR	0.2
13		1161C2 SPRING, THROTTLE RETURN	0.3
14		1161A8 LEVER, CONTROL	0.3
19		(20) BASE, CONTROL	0.3
22		1161B7 SPRING, CABLE RETURN	0.2

Ref. No.	Part No.	Description	Reqd. QTY				Serial No.	Parts catalogue code
			(1)	GX120K1 (2)	(3)	(4)		
1	16263-883-W10	JOINT, ROD	1	-	-	-	KRS4	
2	16500-ZH7-000	CONTROL ASSY.	1	-	-	1	PX, PX2, TX, TXBR, TX2, TX26, TX4, UXU, VX, VXBR, VX4, VX7, WDA6, WD12, WMA3, WMA4, WME4, WMK, WM1	
	16500-ZH7-860	-	(1)	-	-		
3	16500-ZH7-810	CONTROL ASSY. (REMOTE)	1	-	-	-	DS, LAJ, LAJ4, LJ, LJC, LJC8, LJS, LSJ, LSJ4, LTJ, LTK1, LTR, QJG2, QMA8, QME4, QMX2, QWA4, SAJ, SAJ4, SCJ, SG24, SJ, SJC1, SJC5, SKR, SMA7, SMJ, SMW2, VET, WJ, WJP, WKD6, WKT2, WKT4, WKT6, WME2	
	16500-ZH7-850	CONTROL ASSY. (CYCLONE)	-	(1)	-	-	QXC9	
	16500-ZK7-S40	CONTROL ASSY.	1	-	-	-	LTS	
	16500-ZK7-U50	CONTROL ASSY. (REMOTE)	1	-	-	-	QB26, SAR4, SM11, SM12, SM14	
	16500-ZK7-V60	CONTROL ASSY. (REMOTE INT) ..	1	-	-	-	VEE1	
	16570-ZE0-S10	CONTROL ASSY.	1	-	-	-	AR, ARL, DKR, KR, KRA4, KRF4, KRS4, KRT, KRT4, KRT6	
	16570-ZE0-902	CONTROL ASSY. (TAC)	1	-	-	-	STP, STS	
	16570-ZH7-W40	CONTROL ASSY. (TB360)	1	-	-	-	QLL	
	16570-ZK7-U20	CONTROL ASSY.	1	-	-	-	LJD2, SJD2	
	16500-ZK7-S90	1	-	-	-	SYA	
4	16500-ZH7-U42	CONTROL ASSY. (SAKAI)	1	-	-	-	SSK1, SSK3, SSS2, SSS4	
	16500-ZH7-820	CONTROL ASSY. (REMOTE)	1	-	-	1	HHQ4, HTF2, HT2, HT24, HX, HXU, HX2, HX26, HX4, LD, LH, LHQ4, LX, LXU, LX2, LX4, QA, QA2, QD, QDBR, QH, QHQ4, QH26, QM, QMA4, QT, QX, QXBR, QXS2, QXU, QX2, QX26, QX4, QX7, RD, RD4, RHC, RHQ4, RX, RX4, SD, SD16, SD4, SE, SH, SHQ4, SWX2, SWX4, SX, SXS4, SX4, SX7	
5	16500-ZH7-830	CONTROL ASSY. (LOCK TYPE) ...	-	(1)	1	-		
			-	(1)	-	-		
6	16550-ZH7-V30	ARM COMP., GOVERNOR (MEIJI) .	1	-	-	-	SJC5, SMJ	
7	16550-ZK7-V00	ARM COMP., GOVERNOR	1	-	-	-	AR, ARL, DKR, KR, KRA4, KRF4, KRT, KRT4, KRT6	



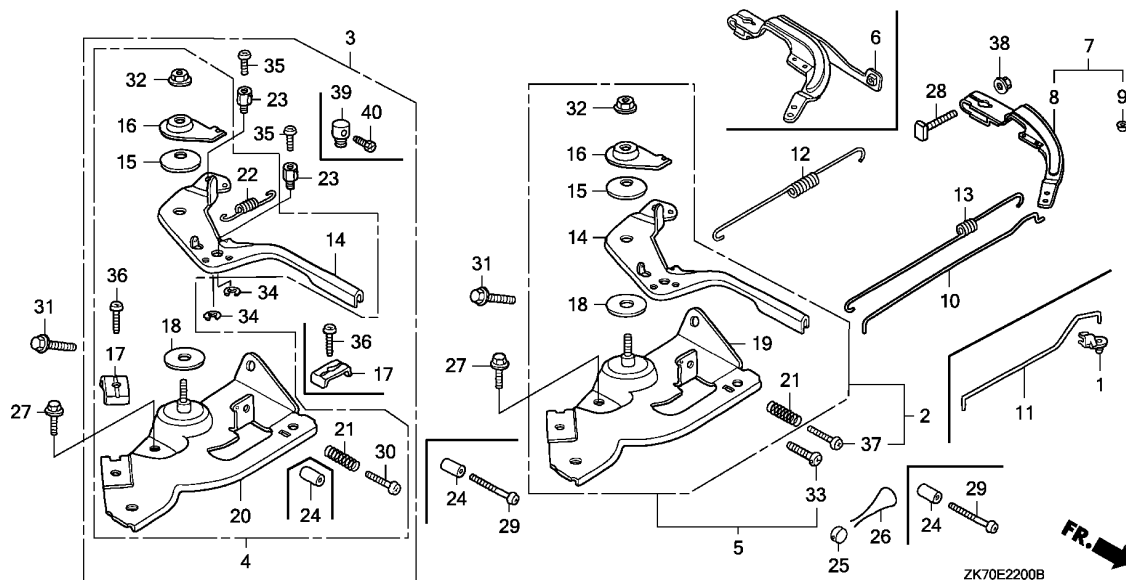

Ref. No.	Part No.	Description	Reqd. QTY				Serial No.	Parts catalogue code
			(1)	(2)	(3)	(4)		
8	16551-ZE0-010	ARM, GOVERNOR	1	-	-	-	DS, HHQ4, HTF2, HT2, HT24, HX, HXU, HX2, HX26, HX4, LAJ, LAJ4, LD, LH, LHQ4, LJ, LJC, LJC8, LJD2, LJS, LSJ, LSJ4, LTJ, LTK1, LTR, LTS, LX, LXU, LX2, LX4, PX, PX2, QA, QA2, QB26, QD, QH, QHQ4, QH26, QJG2, QLL, QM, QMA4, QMA8, QME4, QMX2, QT, QWA4, QX, QXC9, QXS2, QXU, QX2, QX26, QX4, QX7, RD, RD4, RHC, RHQ4, RX, RX4, SAJ, SAJ4, SAR4, SCJ, SD, SD16, SD4, SE, SG24, SH, SHQ4, SJ, SJC1, SJC5, SJD2, SKR, SMA7, SMJ, SMW2, SM11, SM12, SM14, SSK1, SSK3, SSX2, SSX4, STP, STS, SWX2, SWX4, SX, SXS4, SX4, SX7, SYA, TX, TX2, TX26, TX4, UXU, VEE1, VET, VX, VX4, VX7, WDA6, WD12, WJ, WJP, WKD6, WKT2, WKT4, WKT6, WMA3, WMA4, WME2, WME4, WMK, WM1	
	16551-ZK7-S30		-	1	1	1	KRS4	
9	16552-896-650	COLLAR, LEVER	1	-	-	-	AR, ARL, DKR, KR, KRA4, KRF4, KRT, KRT4, KRT6	
10	16555-ZE0-000	ROD, GOVERNOR	1	-	-	-	AR, ARL, DKR, DS, HHQ4, HTF2, HT2, HT24, HX, HXU, HX2, HX26, HX4, KR, KRA4, KRF4, KRT, KRT4, KRT6, LAJ, LAJ4, LD, LH, LHQ4, LJ, LJC, LJC8, LJD2, LJS, LSJ, LSJ4, LTJ, LTK1, LTR, LTS, LX, LXU, LX2, LX4, PX, PX2, QA, QA2, QB26, QD, QH, QHQ4, QH26, QJG2, QLL, QM, QMA4, QMA8, QME4, QMX2, QT, QWA4, QX, QXC9, QXS2, QXU, QX2, QX26, QX4, QX7, RD, RD4, RHC, RHQ4, RX, RX4, SAJ, SAJ4, SAR4, SCJ, SD, SD16, SD4, SE, SG24, SH, SHQ4, SJ, SJC1, SJC5, SJD2, SKR, SMA7, SMJ, SMW2, SM11, SM12, SM14, SSK1, SSK3, SSX2, SSX4, STP, STS, SWX2, SWX4, SX, SXS4, SX4, SX7, SYA, TX, TX2, TX26, TX4, UXU, VEE1, VET, VX, VX4, VX7, WDA6, WD12, WJ, WJP, WKD6, WKT2, WKT4, WKT6, WMA3, WMA4, WME2, WME4, WMK, WM1	
			-	1	1	1		
11	16555-ZK7-S30	ROD, GOVERNOR	1	-	-	-	KRS4	

Ref. No.	Part No.	Description	Reqd. QTY				Serial No.	Parts catalogue code
			(1)	(2)	(3)	(4)		
12	16561-ZE0-020	SPRING, GOVERNOR	1	-	-	-	AR, ARL, DKR, DS, HHQ4, HTF2, HT2, HT24, HX, HXU, HX2, HX26, HX4, KR, KRA4, KRF4, KRS4, KRT, KRT4, KRT6, LAJ, LAJ4, LD, LH, LHQ4, LJ, LJC, LJC8, LJD2, LJS, LJSJ, LJSJ4, LTJ, LTK1, LTR, LTS, LX, LXU, LX2, LX4, PX, PX2, QA, QA2, QB26, QD, QH, QHQ4, QH26, QJG2, QLL, QM, QMA4, QMA8, QME4, QMX2, QT, QWA4, QX, QXC9, QXS2, QXU, QX2, QX26, QX4, QX7, RD, RD4, RHC, RHQ4, RX, RX4, SAJ, SAJ4, SAR4, SCJ, SD, SD16, SD4, SE, SG24, SH, SHQ4, SJ, SJC1, SJC5, SJD2, SKR, SMA7, SMJ, SMW2, SM11, SM12, SM14, SSK1, SSK3, SXS2, SXS4, STP, STS, SWX2, SWX4, SX, SXS4, SX4, SX7, SYA, TX, TX2, TX26, TX4, UXU, VEE1, VET, VX, VX4, VX7, WDA6, WD12, WJ, WJP, WKD6, WKT2, WKT4, WKT6, WMA3, WMA4, WME2, WME4, WMK, WM1	
			-	1	1	1		
13	16562-ZE0-020	SPRING, THROTTLE RETURN	1	-	-	-	AR, ARL, DKR, DS, HHQ4, HTF2, HT2, HT24, HX, HXU, HX2, HX26, HX4, KR, KRA4, KRF4, KRS4, KRT, KRT4, KRT6, LAJ, LAJ4, LD, LH, LHQ4, LJ, LJC, LJC8, LJD2, LJS, LJSJ, LJSJ4, LTJ, LTK1, LTR, LTS, LX, LXU, LX2, LX4, PX, PX2, QA, QA2, QB26, QD, QH, QHQ4, QH26, QJG2, QLL, QM, QMA4, QMA8, QME4, QMX2, QT, QWA4, QX, QXC9, QXS2, QXU, QX2, QX26, QX4, QX7, RD, RD4, RHC, RHQ4, RX, RX4, SAJ, SAJ4, SAR4, SCJ, SD, SD16, SD4, SE, SG24, SH, SHQ4, SJ, SJC1, SJC5, SJD2, SKR, SMA7, SMJ, SMW2, SM11, SM12, SM14, SSK1, SSK3, SXS2, SXS4, STP, STS, SWX2, SWX4, SX, SXS4, SX4, SX7, SYA, TX, TX2, TX26, TX4, UXU, VEE1, VET, VX, VX4, VX7, WDA6, WD12, WJ, WJP, WKD6, WKT2, WKT4, WKT6, WMA3, WMA4, WME2, WME4, WMK, WM1	
			-	1	1	1		
14	16571-ZE0-S10	LEVER, CONTROL	1	-	-	-	AR, ARL, DKR, KR, KRA4, KRF4, KRS4, KRT, KRT4, KRT6, LJD2, SJD2	
	16571-ZH7-U41	1	-	-	-	SSK1, SSK3, SXS2, SXS4, STP, STS	
	16571-ZH7-000	1	-	-	-	DS, HHQ4, HTF2, HT2, HT24, HX, HXU, HX2, HX26, HX4, LAJ, LAJ4, LD, LH, LHQ4, LJ, LJC, LJC8, LJS, LJSJ, LJSJ4, LTJ, LTK1, LTR, LTS, LX, LXU, LX2, LX4, PX, PX2, QA, QA2, QB26, QD, QH, QHQ4, QH26, QJG2, QLL, QM, QMA4, QMA8, QME4, QMX2, QT, QWA4, QX, QXC9, QXS2, QXU, QX2, QX26, QX4, QX7, RD, RD4, RHC, RHQ4, RX, RX4, SAJ, SAJ4, SAR4, SCJ, SD, SD16, SD4, SE, SG24, SH, SHQ4, SJ, SJC1, SJC5, SKR, SMA7, SMJ, SMW2, SM11, SM12, SM14, SWX2, SWX4, SX, SXS4, SX4, SX7, TX, TX2, TX26, TX4, UXU, VEE1, VET, VX, VX4, VX7, WDA6, WD12, WJ, WJP, WKD6, WKT2, WKT4, WKT6, WMA3, WMA4, WME2, WME4, WMK, WM1	
	16571-ZH7-860	-	(1)	1	1		
	16571-ZK7-S90	-	(1)	-	-		
15	16574-ZE1-000	SPRING, LEVER	1	-	-	-	SYA	
			1	-	-	-	AR, ARL, DKR, DS, HHQ4, HTF2, HT2, HT24, HX, HXU, HX2, HX26, HX4, KR, KRA4, KRF4, KRS4, KRT, KRT4, KRT6, LAJ, LAJ4, LD, LH, LHQ4, LJ, LJC, LJC8, LJD2, LJS, LJSJ, LJSJ4, LTJ, LTK1, LTR, LTS, LX, LXU, LX2, LX4, PX, PX2, QA, QA2, QB26, QD, QH, QHQ4, QH26, QJG2, QLL, QM, QMA4, QMA8, QME4, QMX2, QT, QWA4, QX, QXC9, QXS2, QXU, QX2, QX26, QX4, QX7, RD, RD4, RHC, RHQ4, RX, RX4, SAJ, SAJ4, SAR4, SCJ, SD, SD16, SD4, SE, SG24, SH, SHQ4, SJ, SJC1, SJC5, SJD2, SKR, SMA7, SMJ, SMW2, SM11, SM12, SM14, SSK1, SSK3, SXS2, SXS4, STP, STS, SWX2, SWX4, SX, SXS4, SX4, SX7, SYA, TX, TX2, TX26, TX4, UXU, VEE1, VET, VX, VX4, VX7, WDA6, WD12, WJ, WJP, WKD6, WKT2, WKT4, WKT6, WMA3, WMA4, WME2, WME4, WMK, WM1	
			-	(1)	1	1		
16	16575-ZH8-000	WASHER, CONTROL LEVER	1	-	-	-	AR, ARL, DKR, DS, HHQ4, HTF2, HT2, HT24, HX, HXU, HX2, HX26, HX4, KR, KRA4, KRF4, KRS4, KRT, KRT4, KRT6, LAJ, LAJ4, LD, LH, LHQ4, LJ, LJC, LJC8, LJD2, LJS, LJSJ, LJSJ4, LTJ, LTK1, LTR, LTS, LX, LXU, LX2, LX4, PX, PX2, QA, QA2, QB26, QD, QH, QHQ4, QH26, QJG2, QLL, QM, QMA4, QMA8, QME4, QMX2, QT, QWA4, QX, QXC9, QXS2, QXU, QX2, QX26, QX4, QX7, RD, RD4, RHC, RHQ4, RX, RX4, SAJ, SAJ4, SAR4, SCJ, SD, SD16, SD4, SE, SG24, SH, SHQ4, SJ, SJC1, SJC5, SJD2, SKR, SMA7, SMJ, SMW2, SM11, SM12, SM14, SSK1, SSK3, SXS2, SXS4, STP, STS, SWX2, SWX4, SX, SXS4, SX4, SX7, SYA, TX, TX2, TX26, TX4, UXU, VEE1, VET, VX, VX4, VX7, WDA6, WD12, WJ, WJP, WKD6, WKT2, WKT4, WKT6, WMA3, WMA4, WME2, WME4, WMK, WM1	
			-	(1)	1	1		



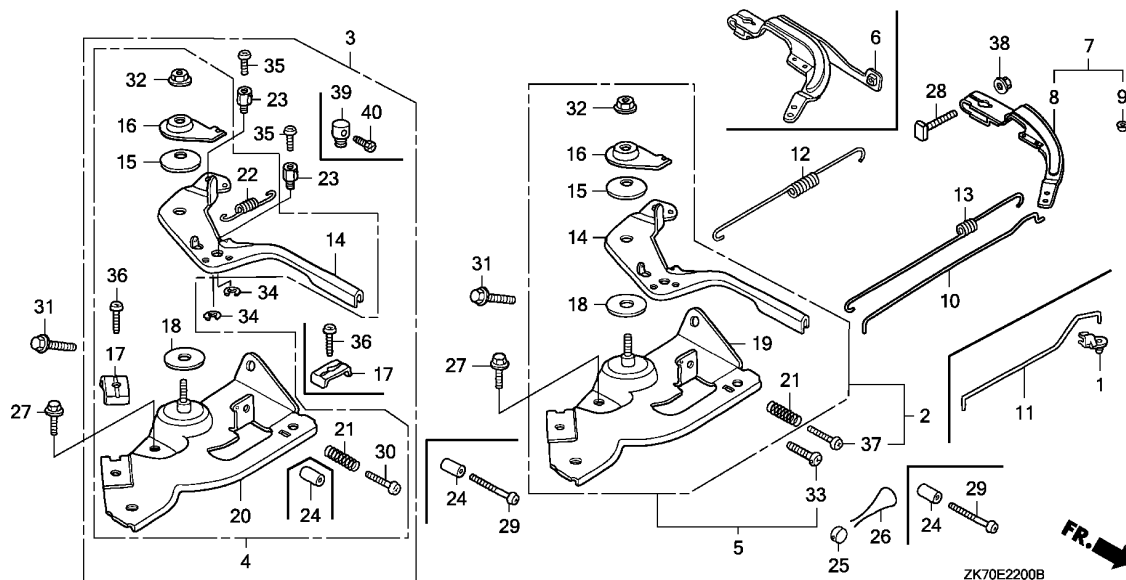

Ref. No.	Part No.	Description	Reqd. QTY				Serial No.	Parts catalogue code
			(1)	(2)	(3)	(4)		
17	16576-891-000	HOLDER, CABLE	1	-	-	1	AR, ARL, DKR, DS, HHQ4, HTF2, HT2, HT24, HX, HXU, HX2, HX26, HX4, KR, KRA4, KRF4, KRS4, KRT, KRT4, KRT6, LAJ, LAJ4, LD, LH, LHQ4, LJ, LJC, LJC8, LJD2, LJS, LSJ, LSJ4, LTJ, LTK1, LTR, LTS, LX, LXU, LX2, LX4, QA, QA2, QD, QDBR, QH, QHQ4, QH26, QJG2, QLL, QM, QMA4, QMA8, QME4, QMX2, QT, QWA4, QX, QXBR, QXC9, QXS2, QXU, QX2, QX26, QX4, QX7, RD, RD4, RHC, RHQ4, RX, RX4, SAJ, SAJ4, SCJ, SD, SD16, SD4, SE, SG24, SH, SHQ4, SJ, SJC1, SJC5, SJD2, SKR, SMA7, SMJ, SMW2, SSK1, SSK3, SSX2, SSX4, STP, STS, SWX2, SWX4, SX, SXS4, SX4, SX7, SYA, VEE1, VET, WJ, WJP, WKD6, WKT2, WKT4, WKT6, WME2, QB26, SAR4, SM11, SM12, SM14	
18	16578-ZE1-000	SPACER, CONTROL LEVER	1	-	-	-	AR, ARL, DKR, DS, HHQ4, HTF2, HT2, HT24, HX, HXU, HX2, HX26, HX4, KR, KRA4, KRF4, KRS4, KRT, KRT4, KRT6, LAJ, LAJ4, LD, LH, LHQ4, LJ, LJC, LJC8, LJD2, LJS, LSJ, LSJ4, LTJ, LTK1, LTR, LTS, LX, LXU, LX2, LX4, PX, PX2, QA, QA2, QB26, QD, QH, QHQ4, QH26, QJG2, QLL, QM, QMA4, QMA8, QME4, QMX2, QT, QWA4, QX, QXC9, QXS2, QXU, QX2, QX26, QX4, QX7, RD, RD4, RHC, RHQ4, RX, RX4, SAJ, SAJ4, SAR4, SCJ, SD, SD16, SD4, SE, SG24, SH, SHQ4, SJ, SJC1, SJC5, SJD2, SKR, SMA7, SMJ, SMW2, SM11, SM12, SM14, SSK1, SSK3, SSX2, SSX4, STP, STS, SWX2, SWX4, SX, SXS4, SX4, SX7, SYA, TX, TX2, TX26, TX4, UXU, VEE1, VET, VX, VX4, VX7, WDA6, WD12, WJ, WJP, WKD6, WKT2, WKT4, WKT6, WMA3, WMA4, WME2, WME4, WMK, WM1	
19	16580-ZH7-000	BASE COMP., CONTROL (###) ...	1	-	-	1	PX, PX2, TX, TXBR, TX2, TX26, TX4, UXU, VX, VXBR, VX4, VX7, WDA6, WD12, WMA3, WMA4, WME4, WMK, WM1	
20	16580-ZH7-R00 16580-ZH7-U40	BASE COMP., CONTROL (###)	1 1	- -	- -	- -	STP, STS SSK1, SSK3, SSX2, SSX4	

Ref. No.	Part No.	Description	Reqd. QTY				Serial No.	Parts catalogue code
			(1)	(2)	(3)	(4)		
20)	16580-ZH7-810	BASE COMP., CONTROL (###) ...	1	-	-	1	-----	AR, ARL, DKR, DS, HHQ4, HTF2, HT2, HT24, HX, HXU, HX2, HX26, HX4, KR, KRA4, KRF4, KRS4, KRT, KRT4, KRT6, LAJ, LAJ4, LD, LH, LHQ4, LJ, LJC, LJC8, LJD2, LJS, LSJ, LSJ4, LTJ, LTK1, LTR, LTS, LX, LXU, LX2, LX4, QA, QA2, QB26, QD, QDBR, QH, QHQ4, QH26, QJG2, QLL, QM, QMA4, QMA8, QME4, QMX2, QT, QWA4, QX, QXBR, QXS2, QXU, QX2, QX26, QX4, QX7, RD, RD4, RHC, RHQ4, RX, RX4, SAJ, SAJ4, SAR4, SCJ, SD, SD16, SD4, SE, SG24, SH, SHQ4, SJ, SJC1, SJC5, SJD2, SKR, SMA7, SMJ, SMW2, SM11, SM12, SM14, SWX2, SWX4, SX, SXS4, SX4, SX7, SYA, VEE1, VET, WJ, WJP, WKD6, WKT2, WKT4, WKT6, WME2
	16580-ZH7-850	BASE COMP., CONTROL (CYCLONE) (###)	-	(1)	1	-	-----	QXC9
21	16584-883-300	SPRING, CONTROL ADJUSTING ...	1	-	-	-	-----	AR, ARL, DKR, DS, HHQ4, HTF2, HT2, HT24, HX, HXU, HX2, HX26, HX4, KR, KRA4, KRF4, KRS4, KRT, KRT4, KRT6, LAJ, LAJ4, LD, LH, LHQ4, LJ, LJC, LJC8, LJD2, LJS, LSJ, LSJ4, LTJ, LTK1, LTR, LTS, LX, LXU, LX2, LX4, PX, PX2, QA, QA2, QB26, QD, QH, QHQ4, QH26, QJG2, QLL, QM, QMA4, QMA8, QME4, QMX2, QT, QWA4, QX, QXC9, QXS2, QXU, QX2, QX26, QX4, QX7, RD, RD4, RHC, RHQ4, RX, RX4, SAJ, SAJ4, SAR4, SCJ, SD, SD16, SD4, SE, SG24, SH, SHQ4, SJ, SJC1, SJC5, SJD2, SKR, SMA7, SMJ, SMW2, SM11, SM12, SM14, SSK1, SSK3, SSX2, SSX4, STP, STS, SWX2, SWX4, SX, SXS4, SX4, SX7, SYA, TX, TX2, TX26, TX4, UXU, VEE1, VET, VX, VX4, VX7, WDA6, WD12, WJ, WJP, WKD6, WKT2, WKT4, WKT6, WMA3, WMA4, WME2, WME4, WMK, WM1
22	16592-ZE1-810	SPRING, CABLE RETURN	-	(1)	1	1	-----	AR, ARL, DKR, DS, HHQ4, HTF2, HT2, HT24, HX, HXU, HX2, HX26, HX4, KR, KRA4, KRF4, KRS4, KRT, KRT4, KRT6, LAJ, LAJ4, LD, LH, LHQ4, LJ, LJC, LJC8, LJD2, LJS, LSJ, LSJ4, LTJ, LTK1, LTR, LTS, LX, LXU, LX2, LX4, QA, QA2, QB26, QD, QDBR, QH, QHQ4, QH26, QJG2, QLL, QM, QMA4, QMA8, QME4, QMX2, QT, QWA4, QX, QXBR, QXC9, QXS2, QXU, QX2, QX26, QX4, QX7, RD, RD4, RHC, RHQ4, RX, RX4, SAJ, SAJ4, SAR4, SCJ, SD, SD16, SD4, SE, SG24, SH, SHQ4, SJ, SJC1, SJC5, SJD2, SKR, SMA7, SMJ, SMW2, SM11, SM12, SM14, SSK1, SSK3, SSX2, SSX4, STP, STS, SWX2, SWX4, SX, SXS4, SX4, SX7, SYA, VEE1, VET, WJ, WJP, WKD6, WKT2, WKT4, WKT6, WME2
23	16594-883-010	HOLDER, WIRE	1	-	-	-	-----	AR, ARL, DKR, DS, KR, KRA4, KRF4, KRS4, KRT, KRT4, KRT6, LAJ, LAJ4, LJ, LJC, LJC8, LJD2, LJS, LSJ, LSJ4, LTJ, LTK1, LTR, LTS, QJG2, QLL, QMA8, QME4, QMX2, QWA4, QXC9, SAJ, SAJ4, SCJ, SG24, SJ, SJC1, SJC5, SJD2, SKR, SMA7, SMJ, SMW2, STP, STS, VEE1, VET, WJ, WJP, WKD6, WKT2, WKT4, WKT6, WME2, QB26, SAR4, SM11, SM12, SM14
24	16599-ZG1-M10	COLLAR, STOPPER	1	-	-	-	-----	LJD2, QLL, SJD2
			(1)	-	-	-	-----	HHQ4, HT24, HX4, KRT4, LAJ4, LHQ4, LSJ4, LX4, QHQ4, QMA4, QMA8, QME4, QWA4, QX4, QX7, RD4, RHC, RHQ4, RX4, SAJ4, SAR4, SD4, SE, SG24, SHQ4, SMA7, SWX2, SXS4, SX4, SX7, TX4, VX4, VX7, WD12, WKT4, WMA3, WMA4, WMK, WM1
25	16727-705-000	END, LOCK	1	-	-	-	-----	VEE1
			-	(1)	-	-	-----	
26	16729-705-010	WIRE, LOCK	1	-	-	-	-----	VEE1
			-	(1)	-	-	-----	



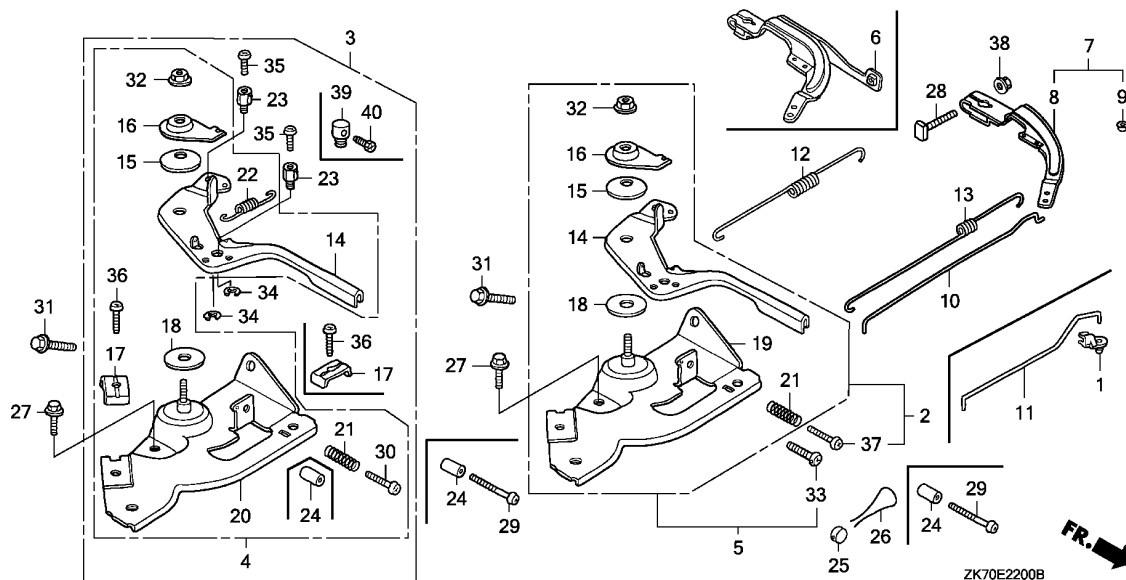

Ref. No.	Part No.	Description	Reqd. QTY				Serial No.	Parts catalogue code
			(1)	(2)	(3)	(4)		
27	90013-883-000	BOLT, FLANGE, 6X12(CT200) ...	1	-	-	-	AR, ARL, DKR, DS, HHQ4, HTF2, HT2, HT24, HX, HXU, HX2, HX26, HX4, KR, KRA4, KRF4, KRS4, KRT, KRT4, KRT6, LAJ, LAJ4, LD, LH, LHQ4, LJ, LJC, LJC8, LJD2, LJS, LSJ, LSJ4, LTJ, LTK1, LTR, LTS, LX, LXU, LX2, LX4, PX, PX2, QA, QA2, QB26, QD, QH, QHQ4, QH26, QJG2, QLL, QM, QMA4, QMA8, QME4, QMX2, QT, QWA4, QX, QXC9, QXS2, QXU, QX2, QX26, QX4, QX7, RD, RD4, RHC, RHQ4, RX, RX4, SAJ, SAJ4, SAR4, SCJ, SD, SD16, SD4, SE, SG24, SH, SHQ4, SJ, SJC1, SJC5, SJD2, SKR, SMA7, SMJ, SMW2, SM11, SM12, SM14, SSK1, SSK3, SSS2, SSS4, STP, STS, SWX2, SWX4, SX, SXS4, SX4, SX7, SYA, TX, TX2, TX26, TX4, UXU, VEE1, VET, VX, VX4, VX7, WDA6, WD12, WJ, WJP, WKD6, WKT2, WKT4, WKT6, WMA3, WMA4, WME2, WME4, WMK, WM1	
28	90015-ZE5-010	BOLT, GOVERNOR ARM	1	-	1	1	AR, ARL, DKR, DS, HHQ4, HTF2, HT2, HT24, HX, HXU, HX2, HX26, HX4, KR, KRA4, KRF4, KRS4, KRT, KRT4, KRT6, LAJ, LAJ4, LD, LH, LHQ4, LJ, LJC, LJC8, LJD2, LJS, LSJ, LSJ4, LTJ, LTK1, LTR, LTS, LX, LXU, LX2, LX4, PX, PX2, QA, QA2, QB26, QD, QH, QHQ4, QH26, QJG2, QLL, QM, QMA4, QMA8, QME4, QMX2, QT, QWA4, QX, QXC9, QXS2, QXU, QX2, QX26, QX4, QX7, RD, RD4, RHC, RHQ4, RX, RX4, SAJ, SAJ4, SAR4, SCJ, SD, SD16, SD4, SE, SG24, SH, SHQ4, SJ, SJC1, SJC5, SJD2, SKR, SMA7, SMJ, SMW2, SM11, SM12, SM14, SSK1, SSK3, SSS2, SSS4, STP, STS, SWX2, SWX4, SX, SXS4, SX4, SX7, SYA, TX, TX2, TX26, TX4, UXU, VEE1, VET, VX, VX4, VX7, WDA6, WD12, WJ, WJP, WKD6, WKT2, WKT4, WKT6, WMA3, WMA4, WME2, WME4, WMK, WM1	
29	90016-ZE7-W00	SCREW, RECESSED, 5X28	(1)	-	-	-	QLL	
	90016-ZG9-N30	SCREW, RECESSED, 5X25	(1)	-	-	-	HHQ4, HT24, HX4, KRT4, LAJ4, LHQ4, LSJ4, LX4, QHQ4, QMA4, QMA8, QME4, QWA4, QX4, QX7, RD4, RHC, RHQ4, RX4, SAJ4, SAR4, SD4, SE, SG24, SHQ4, SMA7, SWX2, SXS4, SX4, SX7, TX4, VX4, VX7, WD12, WKT4, WMA3, WMA4, WMK, WM1	
30	90016-ZG9-N30	SCREW, RECESSED, 5X25	1	-	-	-	LJD2, SJD2	
	90121-ZE0-000	SCREW, LOCK PAN	1	-	-	-	VEE1	

Ref. No.	Part No.	Description	Reqd. QTY				Serial No.	Parts catalogue code
			(1)	(2)	(3)	(4)		
30)	93500-05025-0H	SCREW, PAN, 5X25	1	-	-	1	AR, ARL, DKR, DS, HHQ4, HTF2, HT2, HT24, HX, HXU, HX2, HX26, HX4, KR, KRA4, KRF4, KRS4, KRT, KRT4, KRT6, LAJ, LAJ4, LD, LH, LHQ4, LJ, LJC, LJC8, LJS, LSJ, LSJ4, LTJ, LTK1, LTR, LX, LXU, LX2, LX4, PX, PX2, QA, QA2, QB26, QD, QDBR, QH, QHQ4, QH26, QJG2, QM, QMA4, QMA8, QME4, QMX2, QT, QWA4, QX, QXBR, QXC9, QXS2, QXU, QX2, QX26, QX4, QX7, RD, RD4, RHC, RHQ4, RX, RX4, SAJ, SAJ4, SAR4, SCJ, SD, SD16, SD4, SE, SG24, SH, SHQ4, SJ, SJC1, SJC5, SKR, SMA7, SMJ, SMW2, SM11, SM12, SM14, SSK1, SSK3, SSSX2, SSSX4, STP, STS, SWX2, SWX4, SX, SXS4, SX4, SX7, SYA, TX, TX2, TX26, TX4, UXU, VET, VX, VX4, VX7, WDA6, WD12, WJ, WJP, WKD6, WKT2, WKT4, WKT6, WMA3, WME2, WME4, WMK, WM1	
	93500-05030-0A	SCREW, PAN, 5X30	1	(1)	1	-	LTS	
31	90022-888-010	BOLT, FLANGE, 6X20(CT200) ...	1	-	-	-	AR, ARL, DKR, DS, HHQ4, HTF2, HT2, HT24, HX, HXU, HX2, HX26, HX4, KR, KRA4, KRF4, KRS4, KRT, KRT4, KRT6, LAJ, LAJ4, LD, LH, LHQ4, LJ, LJC, LJC8, LJD2, LJS, LSJ, LSJ4, LTJ, LTK1, LTR, LTS, LX, LXU, LX2, LX4, PX, PX2, QA, QA2, QB26, QD, QH, QHQ4, QH26, QJG2, QLL, QM, QMA4, QMA8, QME4, QMX2, QT, QWA4, QX, QXC9, QXS2, QXU, QX2, QX26, QX4, QX7, RD, RD4, RHC, RHQ4, RX, RX4, SAJ, SAJ4, SAR4, SCJ, SD, SD16, SD4, SE, SG24, SH, SHQ4, SJ, SJC1, SJC5, SJD2, SKR, SMA7, SMJ, SMW2, SM11, SM12, SM14, SSK1, SSK3, SSSX2, SSSX4, STP, STS, SWX2, SWX4, SX, SXS4, SX4, SX7, SYA, TX, TX2, TX26, TX4, UXU, VEE1, VET, VX, VX4, VX7, WDA6, WD12, WJ, WJP, WKD6, WKT2, WKT4, WKT6, WMA3, WMA4, WME2, WME4, WMK, WM1	
32	90114-SA0-000	NUT, SELF-LOCK, 6MM	1	(1)	1	1	AR, ARL, DKR, DS, HHQ4, HTF2, HT2, HT24, HX, HXU, HX2, HX26, HX4, KR, KRA4, KRF4, KRS4, KRT, KRT4, KRT6, LAJ, LAJ4, LD, LH, LHQ4, LJ, LJC, LJC8, LJD2, LJS, LSJ, LSJ4, LTJ, LTK1, LTR, LTS, LX, LXU, LX2, LX4, PX, PX2, QA, QA2, QB26, QD, QH, QHQ4, QH26, QJG2, QLL, QM, QMA4, QMA8, QME4, QMX2, QT, QWA4, QX, QXC9, QXS2, QXU, QX2, QX26, QX4, QX7, RD, RD4, RHC, RHQ4, RX, RX4, SAJ, SAJ4, SAR4, SCJ, SD, SD16, SD4, SE, SG24, SH, SHQ4, SJ, SJC1, SJC5, SJD2, SKR, SMA7, SMJ, SMW2, SM11, SM12, SM14, SSK1, SSK3, SSSX2, SSSX4, STP, STS, SWX2, SWX4, SX, SXS4, SX4, SX7, SYA, TX, TX2, TX26, TX4, UXU, VEE1, VET, VX, VX4, VX7, WDA6, WD12, WJ, WJP, WKD6, WKT2, WKT4, WKT6, WMA3, WMA4, WME2, WME4, WMK, WM1	
33	90121-ZE0-000	SCREW, LOCK PAN	1	(1)	1	1	VEE1	
34	90605-230-000	CIRCLIP, 5MM	1	-	-	-	AR, ARL, DKR, DS, KR, KRA4, KRF4, KRS4, KRT, KRT4, KRT6, LAJ, LAJ4, LJ, LJC, LJC8, LJD2, LJS, LSJ, LSJ4, LTJ, LTK1, LTR, LTS, QJG2, QLL, QMA8, QME4, QMX2, QWA4, QXC9, SAJ, SAJ4, SCJ, SG24, SJ, SJC1, SJC5, SJD2, SKR, SMA7, SMJ, SMW2, STP, STS, SYA, VEE1, VET, WJ, WJP, WKD6, WKT2, WKT4, WKT6, WME2, QB26, SAR4, SM11, SM12, SM14	
35	93500-04006-0H	SCREW, PAN, 4X6	1	-	-	-	AR, ARL, DKR, DS, KR, KRA4, KRF4, KRS4, KRT, KRT4, KRT6, LAJ, LAJ4, LJ, LJC, LJC8, LJD2, LJS, LSJ, LSJ4, LTJ, LTK1, LTR, LTS, QJG2, QLL, QMA8, QME4, QMX2, QWA4, QXC9, SAJ, SAJ4, SCJ, SG24, SJ, SJC1, SJC5, SJD2, SKR, SMA7, SMJ, SMW2, STP, STS, VEE1, VET, WJ, WJP, WKD6, WKT2, WKT4, WKT6, WME2, QB26, SAR4, SM11, SM12, SM14	



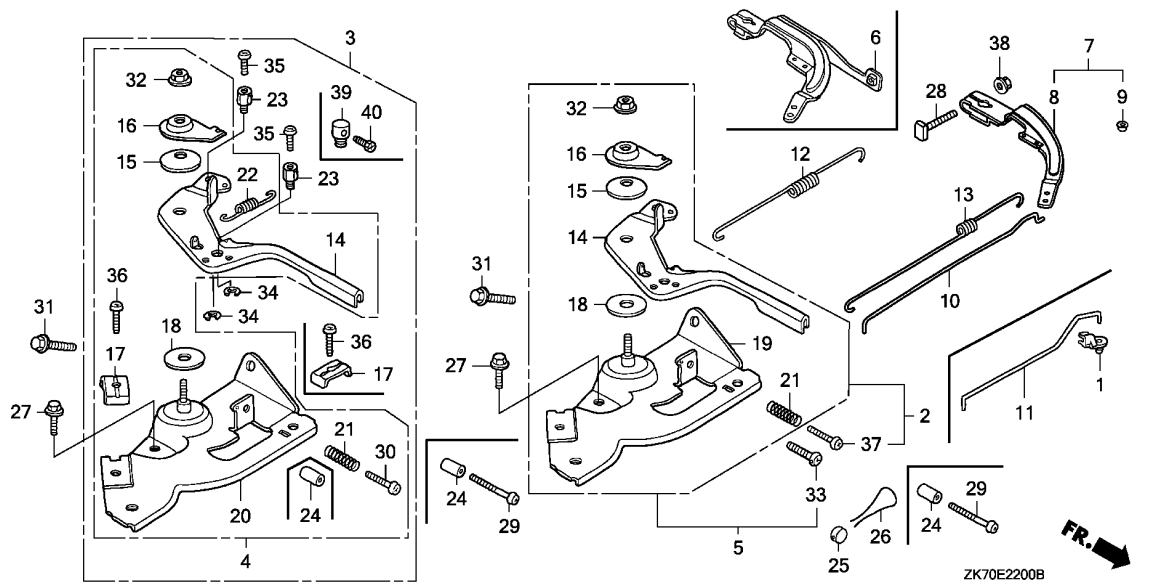

Ref. No.	Part No.	Description	Reqd. QTY				Serial No.	Parts catalogue code
			(1)	(2)	(3)	(4)		
36	93500-05016-0A	SCREW, PAN, 5X16	1	-	-	1	AR, ARL, DKR, DS, HHQ4, HTF2, HT2, HT24, HX, HXU, HX2, HX26, HX4, KR, KRA4, KRF4, KRS4, KRT, KRT4, KRT6, LAJ, LAJ4, LD, LH, LHQ4, LJ, LJC, LJC8, LJD2, LJS, LSJ, LSJ4, LTJ, LTK1, LTR, LTS, LX, LXU, LX2, LX4, QA, QA2, QD, QDBR, QH, QHQ4, QH26, QJG2, QLL, QM, QMA4, QMA8, QME4, QMX2, QT, QWA4, QX, QXBR, QXC9, QXS2, QXU, QX2, QX26, QX4, QX7, RD, RD4, RHC, RHQ4, RX, RX4, SAJ, SAJ4, SCJ, SD, SD16, SD4, SE, SG24, SH, SHQ4, SJ, SJC1, SJC5, SJD2, SKR, SMA7, SMJ, SMW2, SSK1, SSK3, SSX2, SSX4, STP, STS, SWX2, SWX4, SX, SXS4, SX4, SX7, SYA, VEE1, VET, WJ, WJP, WKD6, WKT2, WKT4, WKT6, WME2, QB26, SAR4, SM11, SM12, SM14	
37	93500-05025-0H	SCREW, PAN, 5X25	2	-	-	-	KRT6, PX, PX2, TX, TXBR, TX2, TX26, TX4, UXU, VX, VXBR, VX4, VX7, WDA6, WD12, WMA3, WMA4, WME4, WMK, WM1	
			-	(1)	-	-		
38	94050-06000	NUT, FLANGE, 6MM	1	-	-	-	AR, ARL, DKR, DS, HHQ4, HTF2, HT2, HT24, HX, HXU, HX2, HX26, HX4, KR, KRA4, KRF4, KRS4, KRT, KRT4, KRT6, LAJ, LAJ4, LD, LH, LHQ4, LJ, LJC, LJC8, LJD2, LJS, LSJ, LSJ4, LTJ, LTK1, LTR, LTS, LX, LXU, LX2, LX4, PX, PX2, QA, QA2, QB26, QD, QH, QHQ4, QH26, QJG2, QLL, QM, QMA4, QMA8, QME4, QMX2, QT, QWA4, QX, QXC9, QXS2, QXU, QX2, QX26, QX4, QX7, RD, RD4, RHC, RHQ4, RX, RX4, SAJ, SAJ4, SAR4, SCJ, SD, SD16, SD4, SE, SG24, SH, SHQ4, SJ, SJC1, SJC5, SJD2, SKR, SMA7, SMJ, SMW2, SM11, SM12, SM14, SSK1, SSK3, SSX2, SSX4, STP, STS, SWX2, SWX4, SX, SXS4, SX4, SX7, SYA, TX, TX2, TX26, TX4, UXU, VEE1, VET, VX, VX4, VX7, WDA6, WD12, WJ, WJP, WKD6, WKT2, WKT4, WKT6, WMA3, WMA4, WME2, WME4, WMK, WM1	
			-	1	1	1		
39	16617-ZJ1-840	HOLDER, CABLE	1	-	-	-	SYA	
40	92301-04006-0H	BOLT, RECESSED, 4X6	1	-	-	-	SYA	

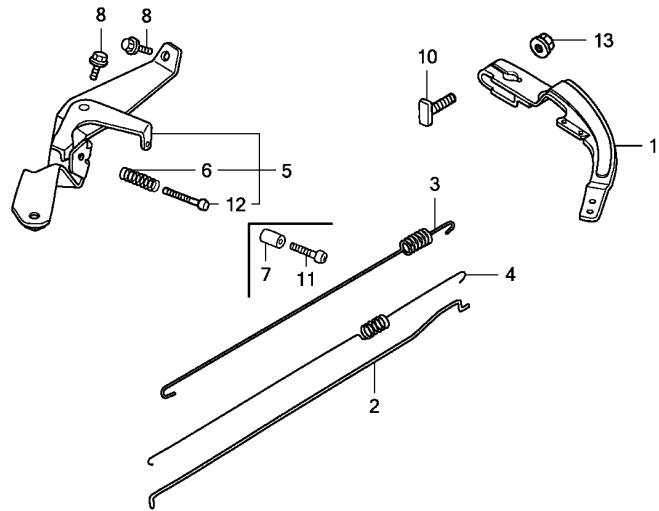

ZK70E2201A

Ref. No.	L.O.N.	(Relative ref. Number) Description	F.R.T.
1	1161A0	ARM, GOVERNOR	0.3
2	1161B1	ROD, GOVERNOR	0.3
3	1161C5	SPRING, GOVERNOR	0.2
4	1161C2	SPRING, THROTTLE RETURN	0.3
5	1161A5	CONTROL, THROTTLE/GOVERNOR ...	0.2

Ref. No.	Part No.	Description	Reqd. QTY				Serial No.	Parts catalogue code
			(1)	GX120K1 (2)	(3)	(4)		
1	16551-ZE0-010	ARM, GOVERNOR	1	-	-	-	VED, VED1, VED6, VEX, VEX7, VMS4, VMT, VPM4, VPR4, VSX, VSX1, VXU	
2	16555-ZE0-000	ROD, GOVERNOR	1	-	-	-	VED, VED1, VED6, VEX, VEX7, VMS4, VMT, VPM4, VPR4, VSX, VSX1, VXU	
3	16561-ZE0-020	SPRING, GOVERNOR	1	-	-	-	VED, VED1, VED6, VEX, VEX7, VMS4, VMT, VPM4, VPR4, VSX, VSX1, VXU	
4	16562-ZE0-020	SPRING, THROTTLE RETURN	1	-	-	-	VED, VED1, VED6, VSX, VSX1	
	16562-ZE1-020	1	-	-	-	VEX, VEX7, VMS4, VMT, VPM4, VPR4, VXU	
5	16570-ZB0-000	CONTROL ASSY.	1	-	-	-	VED, VED1, VED6, VEX, VEX7, VMS4, VMT, VPM4, VPR4, VSX, VSX1, VXU	
6	16584-883-300	SPRING, CONTROL ADJUSTING ...	1	-	-	-	VED, VED1, VED6, VEX, VEX7, VMS4, VMT, VPM4, VPR4, VSX, VSX1, VXU	
7	16599-ZG1-M10	COLLAR, STOPPER	(1)	-	-	-	VEX, VEX7, VMS4, VMT, VPM4, VPR4	
8	90013-883-000	BOLT, FLANGE, 6X12(CT200) ...	2	-	-	-	VED, VED1, VED6, VEX, VEX7, VMS4, VMT, VPM4, VPR4, VSX, VSX1, VXU	
10	90015-ZE5-010	BOLT, GOVERNOR ARM	1	-	-	-	VED, VED1, VED6, VEX, VEX7, VMS4, VMT, VPM4, VPR4, VSX, VSX1, VXU	
11	90016-ZG9-N30	SCREW, RECESSED, 5X25	(1)	-	-	-	VEX, VEX7, VMS4, VMT, VPM4, VPR4	
12	93500-05035-0A	SCREW, PAN, 5X35	1	-	-	-	VED, VED1, VED6, VEX, VEX7, VMS4, VMT, VPM4, VPR4, VSX, VSX1, VXU	
13	94050-06000	NUT, FLANGE, 6MM	1	-	-	-	VED, VED1, VED6, VEX, VEX7, VMS4, VMT, VPM4, VPR4, VSX, VSX1, VXU	



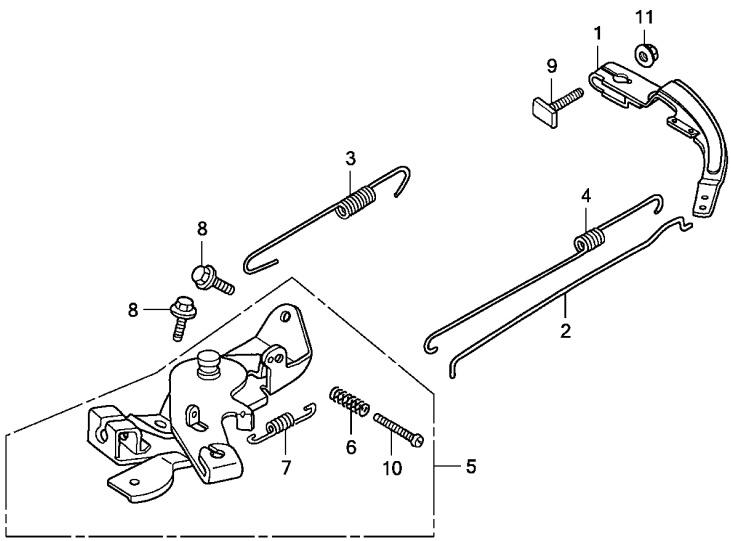

ZK70E2202B

Ref. No.	L.O.N.	(Relative ref. Number) Description	F.R.T.
1	1161A0	ARM, GOVERNOR	0.3
2	1161B1	ROD, GOVERNOR	0.3
3	1161C5	SPRING, GOVERNOR	0.2
4	1161C2	SPRING, THROTTLE RETURN	0.3
5	1161A5	CONTROL, THROTTLE/GOVERNOR ...	0.2

Ref. No.	Part No.	Description	Reqd. QTY				Serial No.	Parts catalogue code
			(1)	GX120K1 (2)	(3)	(4)		
1	16551-ZE0-010	ARM, GOVERNOR	1	-	-	-	-----	VEK
2	16555-ZE0-000	ROD, GOVERNOR	1	-	-	-	-----	VEK
3	16561-733-010	SPRING, GOVERNOR	1	-	-	-	-----	VEK
4	16562-ZE0-020	SPRING, THROTTLE RETURN	1	-	-	-	-----	VEK
5	16570-733-000	CONTROL ASSY.	1	-	-	-	-----	VEK
6	16584-883-300	SPRING, CONTROL ADJUSTING ...	1	-	-	-	-----	VEK
7	16592-ZE1-810	SPRING, CABLE RETURN	1	-	-	-	-----	VEK
8	90013-883-000	BOLT, FLANGE, 6X12(CT200) ...	2	-	-	-	-----	VEK
9	90015-ZE5-010	BOLT, GOVERNOR ARM	1	-	-	-	-----	VEK
10	93500-05028-0A	SCREW, PAN, 5X28	1	-	-	-	-----	VEK
11	94050-06000	NUT, FLANGE, 6MM	1	-	-	-	-----	VEK

E-22-3

CONTROL(4)

J12

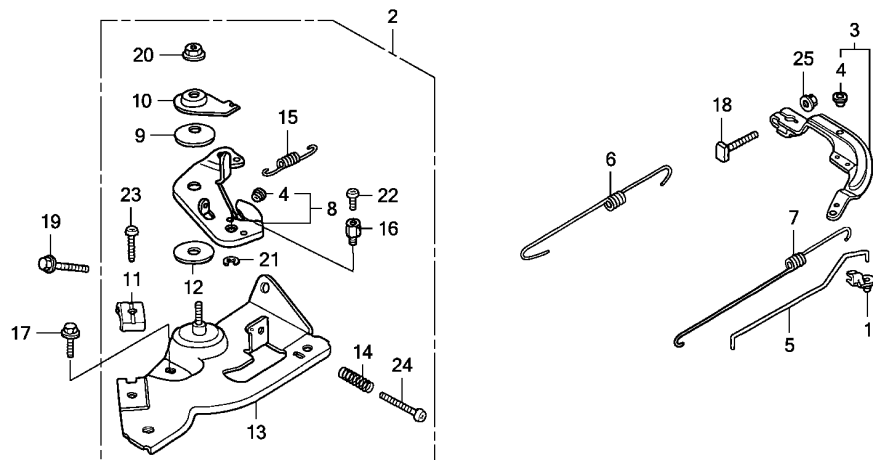

FR. →
ZK70E2203A

Ref. No.	L.O.N.	(Relative ref. Number) Description	F.R.T.
2	1161A5	CONTROL, THROTTLE/GOVERNOR ...	0.2
3	1161A0	ARM, GOVERNOR	0.3
5	1161B1	ROD, GOVERNOR	0.3
6	1161C5	SPRING, GOVERNOR	0.2
7	1161C2	SPRING, THROTTLE RETURN	0.3
8	1161A8	LEVER, CONTROL	0.3
13	1161A2	BASE, CONTROL	0.3
15	1161B7	SPRING, CABLE RETURN	0.2

Ref. No.	Part No.	Description	Reqd. QTY				Serial No.	Parts catalogue code
			(1)	GX120K1 (2)	(3)	(4)		
1	16263-883-W10	JOINT, ROD	1	-	-	-	KRS5,KRS6	
2	16500-ZK7-S50	CONTROL ASSY.	1	-	-	-	KRS5,KRS6	
3	16550-ZK7-S50	ARM COMP., GOVERNOR	1	-	-	-	KRS5,KRS6	
4	16552-896-650	COLLAR, LEVER	2	-	-	-	KRS5,KRS6	
5	16555-ZK7-S30	ROD, GOVERNOR	1	-	-	-	KRS5,KRS6	
6	16561-ZK7-S50	SPRING, GOVERNOR	1	-	-	-	KRS5,KRS6	
7	16562-ZE0-020	SPRING, THROTTLE RETURN	1	-	-	-	KRS5,KRS6	
8	16570-ZK7-S50	LEVER COMP., CONTROL	1	-	-	-	KRS5,KRS6	
9	16574-ZE1-000	SPRING, LEVER	1	-	-	-	KRS5,KRS6	
10	16575-ZH8-000	WASHER, CONTROL LEVER	1	-	-	-	KRS5,KRS6	
11	16576-891-000	HOLDER, CABLE	1	-	-	-	KRS5,KRS6	
12	16578-ZE1-000	SPACER, CONTROL LEVER	1	-	-	-	KRS5,KRS6	
13	16580-ZH7-810	BASE COMP., CONTROL (###)	1	-	-	-	KRS5,KRS6	
14	16584-883-300	SPRING, CONTROL ADJUSTING	1	-	-	-	KRS5,KRS6	
15	16592-ZE1-810	SPRING, CABLE RETURN	1	-	-	-	KRS5,KRS6	
16	16594-883-010	HOLDER, WIRE	1	-	-	-	KRS5,KRS6	
17	90013-883-000	BOLT, FLANGE, 6X12(CT200)	1	-	-	-	KRS5,KRS6	
18	90015-ZE5-010	BOLT, GOVERNOR ARM	1	-	-	-	KRS5,KRS6	
19	90022-888-010	BOLT, FLANGE, 6X20(CT200)	1	-	-	-	KRS5,KRS6	
20	90114-SA0-000	NUT, SELF-LOCK, 6MM	1	-	-	-	KRS5,KRS6	
21	90605-230-000	CIRCLIP, 5MM	1	-	-	-	KRS5,KRS6	
22	93500-04006-OH	SCREW, PAN, 4X6	1	-	-	-	KRS5,KRS6	
23	93500-05016-OA	SCREW, PAN, 5X16	1	-	-	-	KRS5,KRS6	
24	93500-05025-OH	SCREW, PAN, 5X25	1	-	-	-	KRS5,KRS6	
25	94050-06000	NUT, FLANGE, 6MM	1	-	-	-	KRS5,KRS6	

2

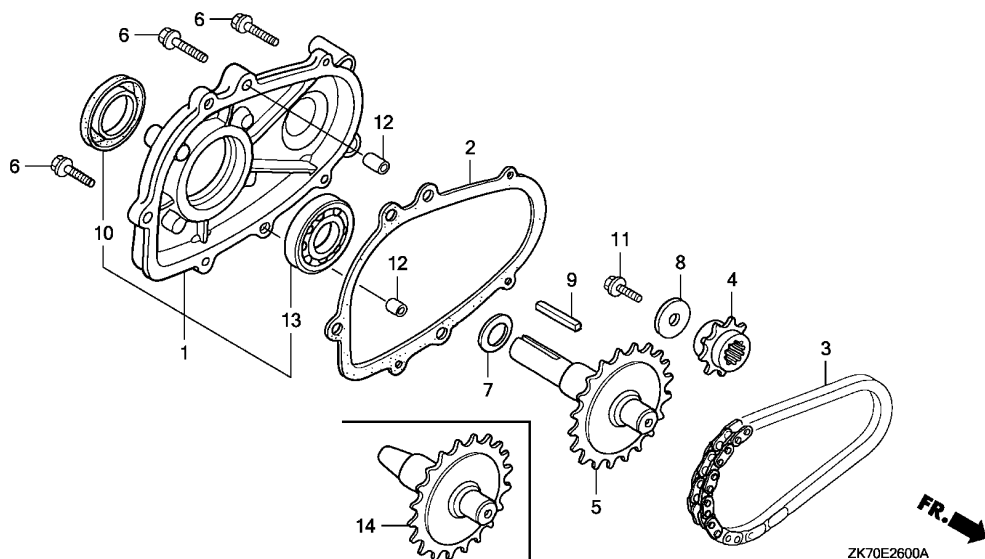

Ref. No.	L.O.N.	(Relative ref. Number) Description	F.R.T.
1		(2)	
1101B2		COVER, CHAIN CASE AND/OR PACKING, CHAIN CASE COVER ...	0.2
3	2141C3	CHAIN, POWER TAKE OFF DRIVE ..	0.3
4	2141J8	SPROCKET, DRIVE	0.3
5		(14)	
	2141H4	SHAFT, POWER TAKE OFF	0.3
10	2141F2	OIL SEAL, POWER TAKE OFF SHAFT	0.2
13	2141A8	BEARING, POWER TAKE OFF SHAFT	0.3

Ref. No.	Part No.	Description	Reqd. QTY				Serial No.	Parts catalogue code
			(1)	GX120K1 (2)	(3)	(4)		
1	11500-ZE1-611	COVER ASSY., CHAIN CASE	1	1	-	-	DS,KRT,KRT4,KRT6,LAJ,LAJ4,LD,LH,LHQ4,LJ,LJC,LJC8,LJD2,LJS,LSJ,LSJ4,LTJ, LTK1,LTR,LTS,LX,LXU,LX2,LX4,L1	
2	11521-ZH8-800	PACKING, CHAIN CASE COVER ...	1	-	-	-	DS,KRT,KRT4,LAJ,LAJ4,LD,LH,LHQ4,LJ,LJC,LJC8,LJD2,LJS,LSJ,LSJ4,LTJ, LTK1,LTR,LTS,LX,LXU,LX2,LX4	
	11521-ZK7-W20	-	(1)	-	-	KRT6	
3	14411-ZE0-611	CHAIN, P.T.O. DRIVE (DID270S-DHA-36LE)	1	1	-	-	DS,LAJ,LAJ4,LD,LH,LHQ4,LJ,LJC,LJC8,LJD2,LJS,LSJ,LSJ4,LTJ,LTK1, LTR,LTS,LX,LXU,LX2,LX4,L1	
	14411-ZH7-V91	CHAIN, P.T.O. DRIVE (DID270FH DHA-36LE)	1	-	-	-	KRT,KRT4,KRT6	
4	23110-ZE0-610	SPROCKET, DRIVE (14T)	1	1	-	-	DS,LAJ,LAJ4,LD,LH,LHQ4,LJ,LJC,LJC8,LJD2,LJS,LSJ,LSJ4,LTJ,LTK1, LTR,LTS,LX,LXU,LX2,LX4,L1	
	23110-ZH7-V90	1	-	-	-	KRT,KRT4,KRT6	
5	23710-ZE0-613	SHAFT, P.T.O. (28T)	1	1	-	-	KRT,KRT4,KRT6,LAJ,LAJ4,LD,LH,LHQ4,LJ,LJC,LJC8,LJD2,LJS,LSJ,LSJ4,LTJ, LTK1,LTR,LTS,LX,LXU,LX2,LX4,L1	
6	90003-ZK7-W20	BOLT, FLANGE, 6X28	5	-	-	-	KRT6	
	90015-883-000	5	5	-	-	DS,KRT,KRT4,LAJ,LAJ4,LD,LH,LHQ4,LJ,LJC,LJC8,LJD2,LJS,LSJ,LSJ4,LTJ, LTK1,LTR,LTS,LX,LXU,LX2,LX4,L1	
7	90456-ZE1-000	SPRING, THRUST	1	1	-	-	DS,KRT,KRT4,KRT6,LAJ,LAJ4,LD,LH,LHQ4,LJ,LJC,LJC8,LJD2,LJS,LSJ,LSJ4,LTJ, LTK1,LTR,LTS,LX,LXU,LX2,LX4,L1	
8	90471-ZE1-610	WASHER, 8MM	1	1	-	-	DS,KRT,KRT4,KRT6,LAJ,LAJ4,LD,LH,LHQ4,LJ,LJC,LJC8,LJD2,LJS,LSJ,LSJ4,LTJ, LTK1,LTR,LTS,LX,LXU,LX2,LX4,L1	
9	90741-883-810	KEY, 5X5X33(YELLOW)	1	(1)	-	-	KRT,KRT4,KRT6,LAJ,LAJ4,LD,LH,LHQ4,LJ,LJC,LJC8,LJD2,LJS,LSJ,LSJ4,LTJ, LTK1,LTR,LTS,LX,LXU,LX2,LX4,L1	
10	91201-Z0T-801	OIL SEAL, 25X41X6	1	1	-	-	DS,KRT,KRT4,KRT6,LAJ,LAJ4,LD,LH,LHQ4,LJ,LJC,LJC8,LJD2,LJS,LSJ,LSJ4,LTJ, LTK1,LTR,LTS,LX,LXU,LX2,LX4,L1	

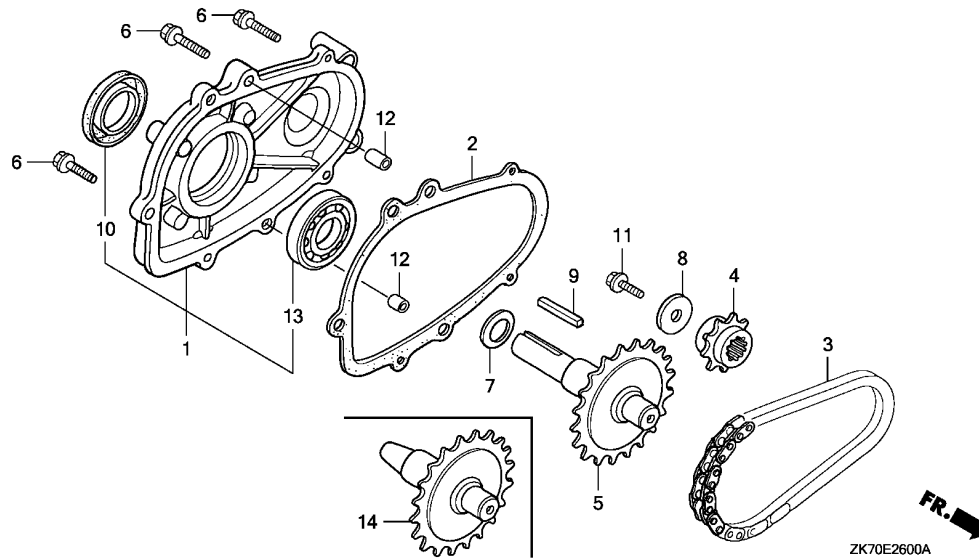

Ref. No.	Part No.	Description	Reqd. QTY				Serial No.	Parts catalogue code
			(1)	GX120K1 (2)	(3)	(4)		
11	92000-08025-0A 92101-08025-0A	BOLT, HEX., 8X25	-	1	-	-	----- L1	DS,KRT,KRT4,KRT6,LAJ,LAJ4,LD,LH,LHQ4,LJ,LJC,LJC8,LJD2,LJS,LSJ
12	94301-08140	DOWEL PIN, 8X14	2	2	-	-	-----	LSJ4,LTJ,LTK1,LTR,LTS,LX,LXU,LX2,LX4 DS,KRT,KRT4,KRT6,LAJ,LAJ4,LD,LH,LHQ4,LJ,LJC,LJC8,LJD2,LJS,LSJ
13	96100-62050-00	BEARING, RADIAL BALL, 6205 ..	1	1	-	-	-----	LSJ4,LTJ,LTK1,LTR,LTS,LX,LXU,LX2,LX4,L1 DS,KRT,KRT4,KRT6,LAJ,LAJ4,LD,LH,LHQ4,LJ,LJC,LJC8,LJD2,LJS,LSJ
14	23710-ZE0-903	SHAFT, P.T.O. (28T)	1	-	-	-	-----	DS



E-26-1

REDUCTION(2)

J15

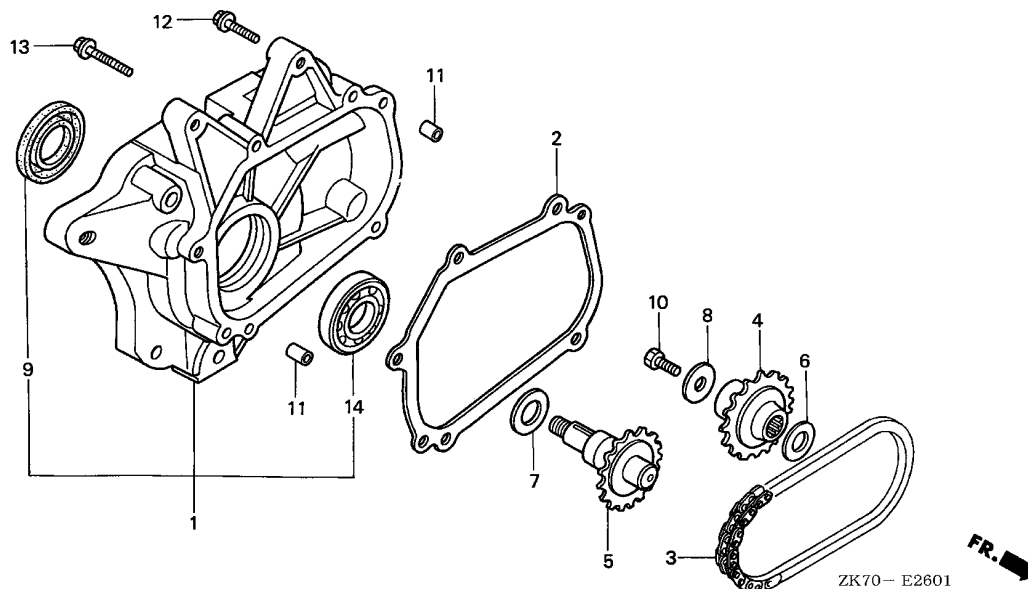

Ref. No.	L.O.N.	(Relative ref. Number) Description	F.R.T.
1	(2)		
2141W6		COVER, CHAIN CASE AND/OR PACKING, CHAIN CASE COVER (STD-TYPE)	0.2
3 2141W4		CHAIN, POWER TAKE OFF DRIVE (STD-TYPE)	0.3
4 2141Y8		SPROCKET, POWER TAKE OFF DRIVE CHAIN(STD-TYPE)	0.3
5 2141W0		SHAFT, POWER TAKE OFF (STD-TYPE)	0.3
9 2141X6		OIL SEAL, POWER TAKE OFF SHAFT (STD-TYPE) :REAR	0.2
14 2141Y1		BEARING, POWER TAKE OFF SHAFT (STD-TYPE) :REAR	0.3

Ref. No.	Part No.	Description	Reqd. QTY				Serial No.	Parts catalogue code
			(1)	GX120K1 (2)	(3)	(4)		
1	11500-ZK7-V00	COVER ASSY., CHAIN CASE	1	-	-	-	AR,ARL,DKR,KR,KRA4,KRF4,KRS4,KRS5,KRS6	
2	11521-ZK7-V00	PACKING, CHAIN CASE COVER ...	1	-	-	-	AR,ARL,DKR,KR,KRA4,KRF4,KRS4,KRS5,KRS6	
3	14411-ZK7-V01	CHAIN, P.T.O. DRIVE	1	-	-	-	AR,ARL,DKR,KR,KRA4,KRF4,KRS4,KRS5,KRS6	
4	23121-ZK7-V00	SPROCKET, DRIVE (17T)	1	-	-	-	AR,ARL,DKR,KR,KRA4,KRF4,KRS4,KRS5,KRS6	
5	23151-ZK7-V00	SHAFT, P.T.O. (16T)	1	-	-	-	AR,ARL,DKR,KR,KRA4,KRF4,KRS4,KRS5,KRS6	
6	90454-428-000	WASHER, THRUST, 20MM	1	-	-	-	AR,ARL,DKR,KR,KRA4,KRF4,KRS4,KRS5,KRS6	
7	90456-ZE1-000	SPRING, THRUST	1	-	-	-	AR,ARL,DKR,KR,KRA4,KRF4,KRS4,KRS5,KRS6	
8	90471-ZE1-610	WASHER, 8MM	1	-	-	-	AR,ARL,DKR,KR,KRA4,KRF4,KRS4,KRS5,KRS6	
9	91252-888-003	OIL SEAL, 25X38X7(ARAI)	1	-	-	-	AR,ARL,DKR,KR,KRA4,KRF4,KRS4,KRS5,KRS6	
10	92101-08025-0A	BOLT, HEX., 8X25	1	-	-	-	AR,ARL,DKR,KR,KRA4,KRF4,KRS4,KRS5,KRS6	
11	94303-08140	DOWEL PIN, 8X14	2	-	-	-	AR,ARL,DKR,KR,KRA4,KRF4,KRS4,KRS5,KRS6	
12	95701-08035-00	BOLT, FLANGE, 8X35	4	-	-	-	AR,ARL,DKR,KR,KRA4,KRF4,KRS4,KRS5,KRS6	
13	95701-08055-00	BOLT, FLANGE, 8X55	1	-	-	-	AR,ARL,DKR,KR,KRA4,KRF4,KRS4,KRS5,KRS6	
14	96100-60050-00	BEARING, RADIAL BALL, 6005 ..	1	-	-	-	AR,ARL,DKR,KR,KRA4,KRF4,KRS4,KRS5,KRS6	

2

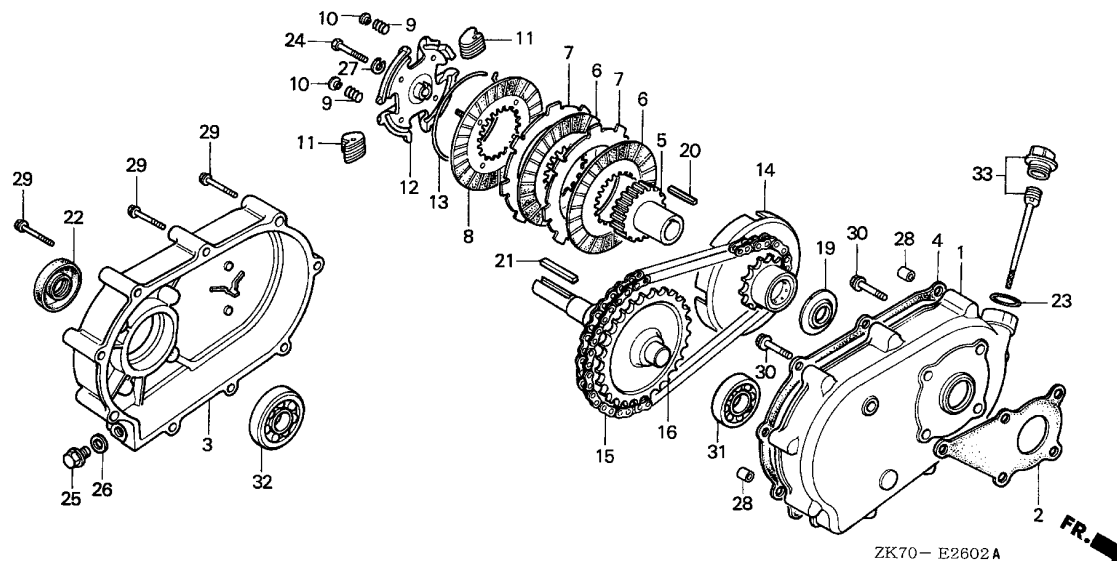

ZK70-E2602A

Ref. No.	L.O.N.	(Relative ref. Number) Description	F.R.T.
1	(2)	CASE, REDUCTION(R-TYPE)	0.3
3	(4)	COVER, REDUCTION AND/OR PACKING, REDUCTION COVER (R-TYPE)	0.3
6	2141Z0	DISC, REDUCTION CLUTCH FRICTION	0.3
7	2141Z1	PLATE, REDUCTION CLUTCH	0.3
8	2141Z2	PLATE, REDUCTION CLUTCH PRESSURE	0.3
14	2141X1	SPROCKET, POWER TAKE OFF DRIVE CHAIN(R-TYPE)	0.3
15	2141W3	CHAIN, POWER TAKE OFF DRIVE (R-TYPE)	0.3
16	2141V8	SHAFT, POWER TAKE OFF(R-TYPE)	0.3
22	2141X4	OIL SEAL, POWER TAKE OFF SHAFT (R-TYPE) :REAR	0.3
31	2141Y5	BEARING, POWER TAKE OFF SHAFT (R-TYPE) :FRONT	0.4
32	2141X9	BEARING, POWER TAKE OFF SHAFT (R-TYPE) :REAR	0.4

Ref. No.	Part No.	Description	Reqd. QTY				Serial No.	Parts catalogue code
			(1)	GX120K1 (2)	(3)	(4)		
1	21510-883-621	CASE, REDUCTION	1	1	-	-	RD, RD4, RHC, RHQ4, RX, RX4, R1	
2	21591-ZH8-620	PACKING, REDUCTION CASE	1	1	-	-	RD, RD4, RHC, RHQ4, RX, RX4, R1	
3	21610-822-611	COVER, REDUCTION	1	1	-	-	RD, RD4, RHC, RHQ4, RX, RX4, R1	
4	21691-ZH8-800	PACKING, REDUCTION COVER	1	1	-	-	RD, RD4, RHC, RHQ4, RX, RX4, R1	
5	22121-887-620	CENTER, CLUTCH (28T)	1	1	-	-	RD, RD4, RHC, RHQ4, RX, RX4, R1	
6	22201-822-610	DISK, CLUTCH FRICTION	2	2	-	-	RD, RD4, RHC, RHQ4, RX, RX4, R1	
7	22311-822-610	PLATE, CLUTCH	2	2	-	-	RD, RD4, RHC, RHQ4, RX, RX4, R1	
8	22350-822-610	PLATE COMP., CLUTCH PRESSURE	1	1	-	-	RD, RD4, RHC, RHQ4, RX, RX4, R1	
9	22411-822-611	SPRING, CLUTCH FREE	4	4	-	-	RD, RD4, RHC, RHQ4, RX, RX4, R1	
10	22421-822-610	HOLDER, CLUTCH SPRING	4	4	-	-	RD, RD4, RHC, RHQ4, RX, RX4, R1	
11	22521-822-610	WEIGHT, CLUTCH	48	48	-	-	RD, RD4, RHC, RHQ4, RX, RX4, R1	
12	22531-887-620	HOLDER, CLUTCH WEIGHT	1	1	-	-	RD, RD4, RHC, RHQ4, RX, RX4, R1	
13	22535-822-610	CENTER, CLUTCH WEIGHT	1	1	-	-	RD, RD4, RHC, RHQ4, RX, RX4, R1	
14	23120-883-620	SPROCKET COMP., DRIVE	1	1	-	-	RD, RD4, RHC, RHQ4, RX, RX4, R1	
15	23161-822-611	CHAIN, DRIVE (RK428SH-36LE) ..	1	1	-	-	RD, RD4, RHC, RHQ4, RX, RX4, R1	
16	23711-822-610	SHAFT COMP., P.T.O. (28T) ...	1	1	-	-	RD, RD4, RHC, RHQ4, RX, RX4, R1	
19	90403-887-620	WASHER, THRUST, 18MM	1	1	-	-	RD, RD4, RHC, RHQ4, RX, RX4, R1	
20	90741-883-621	KEY, 5MM	1	1	-	-	RD, RD4, RHC, RHQ4, RX, RX4, R1	
21	90741-889-810	KEY, 7X7X33(YELLOW)	1	1	-	-	RD, RD4, RHC, RHQ4, RX, RX4, R1	
22	91202-805-610	OIL SEAL (PJ30507)	1	1	-	-	4538605 RD, RX, R1	
	91202-Z2F-801	OIL SEAL, 30X50X7	1	1	-	-	RD4, RHC, RHQ4, RX4	
23	91301-805-000	O-RING, 26X2.7	1	1	-	-	4538606 RD, RX, R1	
24	92101-08035-0A	BOLT, HEX., 8X35	1	1	-	-	RD, RD4, RHC, RHQ4, RX, RX4, R1	
25	92800-12000	BOLT, DRAIN PLUG, 12MM	1	1	-	-	RD, RD4, RHC, RHQ4, RX, RX4, R1	



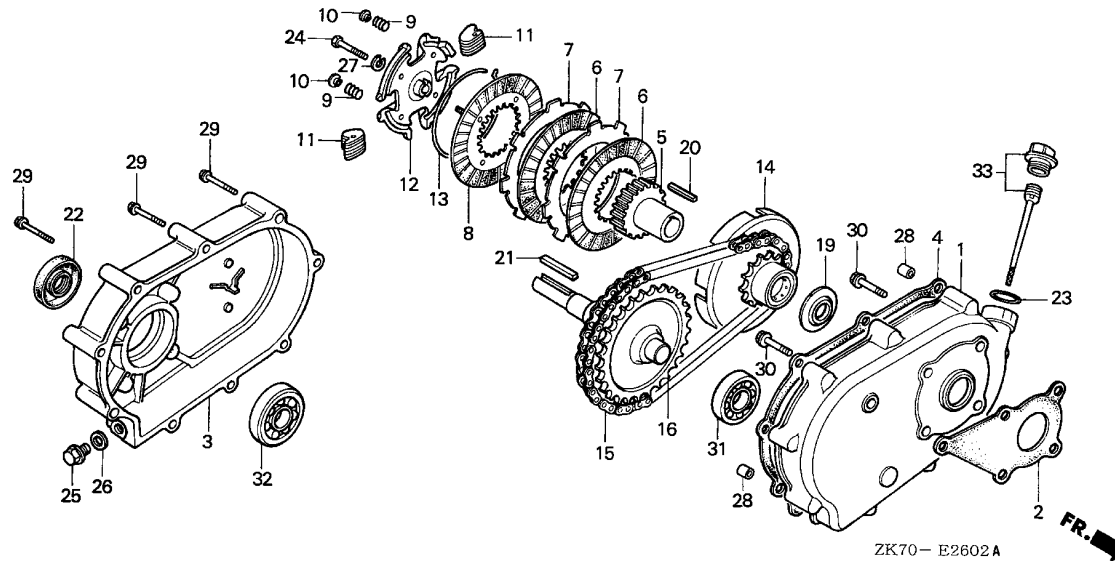

Ref. No.	Part No.	Description	Reqd. QTY				Serial No.	Parts catalogue code
			(1)	GX120K1 (2)	(3)	(4)		
26	94109-12000	WASHER, DRAIN PLUG, 12MM	1	1	-	-	RD, RD4, RHC, RHQ4, RX, RX4, R1	
27	94111-08800	WASHER, SPRING, 8MM	1	1	-	-	RD, RD4, RHC, RHQ4, RX, RX4, R1	
28	94301-08100	DOWEL PIN, 8X10	2	2	-	-	RD, RD4, RHC, RHQ4, RX, RX4, R1	
29	95701-06055-00	BOLT, FLANGE, 6X55	9	9	-	-	RD, RD4, RHC, RHQ4, RX, RX4, R1	
30	95701-08022-00	BOLT, FLANGE, 8X22	5	5	-	-	RD, RD4, RHC, RHQ4, RX, RX4, R1	
31	96100-62050-00	BEARING, RADIAL BALL, 6205	1	1	-	-	RD, RD4, RHC, RHQ4, RX, RX4, R1	
32	96100-62060-00	BEARING, RADIAL BALL, 6206	1	1	-	-	RD, RD4, RHC, RHQ4, RX, RX4, R1	
33	15600-ZH7-000	CAP ASSY., OIL FILLER	1	1	-	-	RD, RD4, RHC, RHQ4, RX, RX4, R1	

E-26-3

REDUCTION(4)

K 2

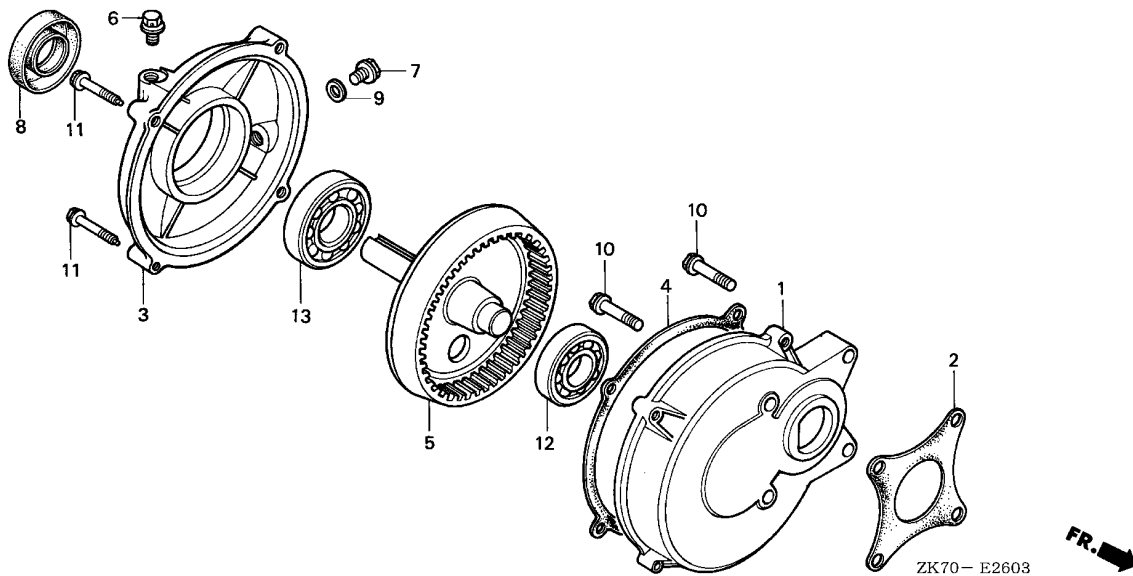

Ref. No.	L.O.N.	(Relative ref. Number) Description	F.R.T.
1		(2)	
2141Y7		CASE, REDUCTION(H-TYPE)	0.2
3		(4)	
2141W8		COVER, REDUCTION AND/OR PACKING, REDUCTION COVER (H-TYPE)	0.2
5	2141V9	SHAFT, POWER TAKE OFF(H-TYPE)	0.2
8	2141X5	OIL SEAL, POWER TAKE OFF SHAFT (H-TYPE) :REAR	0.2
12	2141Y4	BEARING, POWER TAKE OFF SHAFT (H-TYPE) :FRONT	0.3
13	2141Y0	BEARING, POWER TAKE OFF SHAFT (H-TYPE) :REAR	0.3

Ref. No.	Part No.	Description	Reqd. QTY				Serial No.	Parts catalogue code
			(1)	GX120K1 (2)	(3)	(4)		
1	21521-883-741	CASE, REDUCTION	1	1	-	-	HHQ4,HTF2,HT2,HT24,HX,HXU,HX2,HX26,HX4,H1	
2	21591-ZH8-740	PACKING, REDUCTION CASE	1	(1)	-	-	HHQ4,HTF2,HT2,HT24,HX,HXU,HX2,HX26,HX4,H1,Q1,R1,W1	
3	21621-883-741	COVER, REDUCTION	1	1	-	-	HHQ4,HTF2,HT2,HT24,HX,HXU,HX2,HX26,HX4,H1	
4	21692-ZH8-800	PACKING, REDUCTION COVER	1	(1)	-	-	HHQ4,HTF2,HT2,HT24,HX,HXU,HX2,HX26,HX4,H1,Q1,R1,W1	
5	23710-883-740	SHAFT, P.T.O. (86T)	1	1	-	-	HHQ4,HTF2,HT2,HT24,HX,HXU,HX2,HX26,HX4,H1	
6	90002-883-740	BOLT, BREATHING	1	1	-	-	HHQ4,HTF2,HT2,HT24,HX,HXU,HX2,HX26,HX4,H1	
7	90131-883-000	BOLT, DRAIN PLUG, 12X15	1	1	-	-	HHQ4,HTF2,HT2,HT24,HX,HXU,HX2,HX26,HX4,H1	
8	91201-Z0T-801	OIL SEAL, 25X41X6	1	1	-	-	HHQ4,HTF2,HT2,HT24,HX,HXU,HX2,HX26,HX4,H1	
9	94109-12000	WASHER, DRAIN PLUG, 12MM	1	1	-	-	HHQ4,HTF2,HT2,HT24,HX,HXU,HX2,HX26,HX4,H1	
10	95701-08032-08	BOLT, FLANGE, 8X32	4	4	-	-	HHQ4,HTF2,HT2,HT24,HX,HXU,HX2,HX26,HX4,H1	
11	95701-08035-00	BOLT, FLANGE, 8X35	4	4	-	-	HHQ4,HTF2,HT2,HT24,HX,HXU,HX2,HX26,HX4,H1	
12	96100-62040-00	BEARING, RADIAL BALL, 6204 ..	1	1	-	-	HHQ4,HTF2,HT2,HT24,HX,HXU,HX2,HX26,HX4,H1	
13	96100-63050-00	BEARING, RADIAL BALL, 6305 ..	1	1	-	-	HHQ4,HTF2,HT2,HT24,HX,HXU,HX2,HX26,HX4,H1	

2

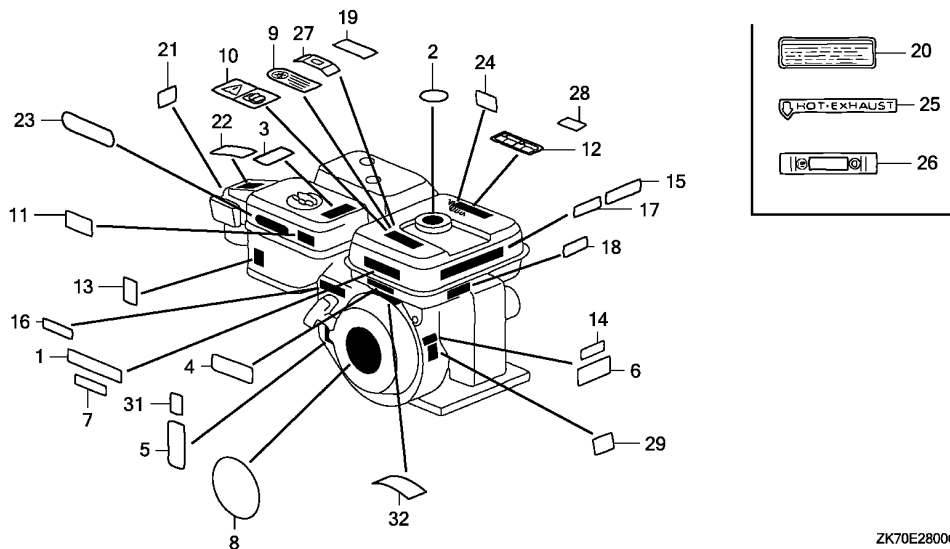

ZK70E2800C

Ref. L.O.N. (Relative ref. Number) F.R.T.
No. Description

NO INFORMATION

Ref. No.	Part No.	Description	Reqd. QTY				Serial No.	Parts catalogue code
			(1)	(2)	(3)	(4)		
1	87101-733-000	MARK, TOP	-	(1)	1	-		
	87522-ZH9-010	LABEL, CAUTION (ENGLISH, ETC.)	1	(1)	-	-	AR,HTF2,HT2,HX,HXU,HX26,KRS4,KRS5,KRS6,LD,LH,LJC8,LX,LXU,LX2 PX,PX2,QA,QA2,QD,QH,QH26,QJG2,QM,QMX2,QWA4,QX,QXC9,QXS2,QXU QX2,QX26,Q1,RD,RX,SD,SD16,SG24,SH,SMW2,SM12,SSK1,SSX2,SWX2,SX SXS4,TX,TX2,TX26,UXU,VED,VED1,VED6,VSX,VSX1,VX,VXU,WDA6,WD12 WKD6,WKT2,WKT6,WME2	
	87522-ZH9-820	LABEL, CAUTION (THAI)	1	-	-	-	4462599 HX2	
	87522-ZH9-821	1	-	-	-	QT	
	87522-ZK7-800	LABEL, CAUTION	-	-	-	1		
	87528-ZE0-900	MARK, ENGINE OPERATION (J) ..	1	-	-	-	STP,STS	
2	87522-ZE1-810	MARK, CAUTION	1	-	-	-	QT	
	87106-ZH8-S00	MARK, FUEL CAUTION (SHJ)	-	-	1	-		
3	87106-737-J00	MARK, FUEL WARNING	1	-	-	-	VEK	
4	87135-ZE2-020	LABEL, E-SPEC (15.5X27.5) ...	1	-	-	-	4410587 HHQ4,HX4,KRA4,KRF4,KRT4,LAJ4,LHQ4,LSJ4,LX4,QHQ4,QLL,QMA4,QMA8 QME4,QX4,QX7,RD4,RHC,RHQ4,RX4,SAJ4,SD4,SE,SHQ4,SMA7,SM14,SSX4 SWX4,SX4,SX7,TX4,VED6,VEX,VEX7,VMS4,VPR4,VX4,VX7,WDA6,WKD6 WKT4,WMA3,WME4	
			1	-	-	-	4500394 DS,HX,HXU,LAJ,LD,LH,LJ,LJC,LJC8,LJS,LSJ,LTJ,LTK1,LTR,LTS,LX LXU,PX,QA,QD,QH,QX,QXU,RD,RX,SAJ,SCJ,SD,SH,SJ,SJC1,SJC5,SKR SMJ,SM11,SSK1,SSK3,STP,STS,SX,TX,UXU,VED,VED1,VEE1,VEK,VET,VSX VSX1,VX,VXU,WJ,WJP,WM1	
5	87135-ZE2-020	LABEL, E-SPEC (15.5X27.5) ...	-	-	-	1		
			1	-	-	-	KRA4,KRF4,KRT4,QB26,RHC,VPR4	
			1	-	-	-	4500394 DKR,KR,KRT,KRT6,VMT	
			-	1	-	-	4500394	
6	87152-ZH7-C31	LABEL, SPEC	1	-	-	-	VEK	

Ref. No.	Part No.	Description	Reqd. QTY				Serial No.	Parts catalogue code
			(1)	GX120K1 (2)	(3)	(4)		
7	87520-ZH8-000	MARK A, COMBINATION	1	-	-	-	DS, KR, KRT, KRT6, LJ, LJC, LJS, LSJ, LTJ, LTK1, LTR, LTS, SAJ, SCJ, SJ, SJC1, SJC5, SMJ, SM11, SSK3, STP, STS, VEE1, VET, WJ, WJP	
8	87521-ZH7-Y11	EMBLEM	1	(1)	-	-	QT	
	87521-ZH7-832	EMBLEM (THAI)	-	(1)	-	-		
	87521-ZH7-020	EMBLEM	-	-	1	1		
	87521-ZH7-030	EMBLEM (4.0)	1	-	-	-	AR, DKR, HHQ4, HTF2, HT2, HT24, HXU, HX2, HX26, HX4, KRA4, KRF4, KRS4, KRS5, KRS6, KRT4, LAJ4, LD, LHQ4, LSJ, LSJ4, LXU, LX2, LX4, PX2, QA, QA2, QD, QH26, QJG2, QLL, QMA4, QMA8, QME4, QMX2, QWA4, QXC9, QXS2, QXU, QX2, QX26, QX4, QX7, RD, RD4, RHC, RHQ4, RX4, SAJ4, SAR4, SD16, SD4, SE, SG24, SH, SHQ4, SMA7, SMW2, SM12, SM14, SSK1, SSS2, SSS4, SWX2, SWX4, SXS4, SX4, SX7, TX, TX2, TX26, TX4, UXU, VED1, VED6, VEE1, VET, VEX, VEX7, VMS4, VPM4, VPR4, VXU, VX4, VX7, WDA6, WD12, WJP, WKD6, WKT2, WKT4, WKT6, WMA3, WME2, WME4, WM1	
			1	-	-	-	4553667 ARL, DS, HX, KR, KRT, KRT6, LAJ, LH, LJ, LJC, LJC8, LJS, LTJ, LTK1, LTR, LTS, LX, PX, QH, QM, QX, RX, SAJ, SCJ, SD, SJ, SJC1, SJC5, SKR, SMJ, SM11, SSK3, STP, STS, SX, VED, VEK, VMT, VSX, VSX1, VX, WJ, WMA4, WMK	
	87521-ZH7-040	EMBLEM (GX120)	1	-	-	-	4553668 ARL, DS, HX, KR, KRT, KRT6, LAJ, LH, LJ, LJC, LJC8, LJS, LTJ, LTK1, LTR, LTS, LX, PX, QH, QM, QX, RX, SAJ, SCJ, SD, SJ, SJC1, SJC5, SKR, SMJ, SM11, SSK3, STP, STS, SX, VED, VEK, VMT, VSX, VSX1, VX, WJ, WMA4, WMK	
9	87522-ZB3-K01	MARK, FIRE DANGER	-	1	-	-	4553668	
10	87522-ZH8-W41	MARK, CAUTION (PICTOGRAPH) ..	1	-	-	-	DKR, HHQ4, HX4, KRA4, KRF4, KRS4, KRS5, KRS6, KRT4, LAJ4, LHQ4, LSJ4, LX4, QH26, QLL, QMA4, QMA8, QME4, QWA4, QX4, QX7, RD4, RHQ4, RX4, SAJ4, SAR4, SD4, SE, SG24, SHQ4, SMA7, SM14, SSS4, SWX4, SXS4, SX4, SX7, TX4, VEX, VEX7, VMS4, VX4, VX7, WKT4, WMA3, WME4, WMK	
			1	-	-	-	4453887 SWX2	
11	87524-883-690	MARK, AIR CLEANER CAUTION (OIL BATH) (ARABIC)	1	-	-	-	QT	
12	87526-ZH8-000	MARK B, COMBINATION	1	(1)	-	-	DS, KR, KRT, KRT6, LAJ, LJ, LJC, LJS, LSJ, LTJ, LTK1, LTR, LTS, SAJ, SCJ, SJ, SJC1, SJC5, SMJ, SM11, SSK3, STP, STS, VEE1, VET, WJ, WJP	
13	87528-ZB2-630	MARK, CHOKE	1	-	-	-	VMT, VPM4, VPR4	
	87528-ZE1-690	MARK, CHOKE (THAI)	1	-	-	-	QT	
	87528-ZE1-810	MARK, CHOKE	1	-	-	-	AR, DS, HTF2, HT2, HX, HXU, HX26, KR, KRS4, KRS5, KRS6, KRT, KRT6, LAJ, LD, LH, LJ, LJC, LJC8, LJS, LSJ, LTJ, LTK1, LTR, LTS, LX, LXU, LX2, PX, PX2, QA, QA2, QD, QH, QH26, QJG2, QM, QMX2, QWA4, QX, QXC9, QXS2, QXU, QX2, QX26, RD, RX, SAJ, SCJ, SD, SD16, SH, SJ, SJC1, SJC5, SKR, SMJ, SMW2, SM11, SM12, SSK1, SSK3, SSS2, STP, STS, SWX2, SX, TX, TX2, TX26, UXU, VED, VED1, VED6, VEE1, VET, VSX, VSX1, VX, VXU, WDA6, WD12, WJ, WJP, WKD6, WKT2, WKT6, WME2, HX2	
			1	(1)	-	1	4462599	
	87528-777-000	1	-	-	-	VEK	
	87528-ZH8-S00	-	-	1	-		
	87528-733-E90	MARK, CHOKE (H=36)	1	-	-	-	4335503 DKR, HHQ4, HX4, KRA4, KRF4, KRS4, KRT4, LAJ4, LHQ4, LJD2, LSJ4, LX4, QH26, QLL, QMA4, QMA8, QME4, QWA4, QX4, QX7, RD4, RHC, RHQ4, RX4, SAJ4, SD4, SE, SG24, SHQ4, SJD2, SMA7, SM14, SSS4, SWX4, SXS4, SX4, SX7, TX4, VEX, VEX7, VMS4, VX4, VX7, WKT4, WMA3, WME4, WM1	



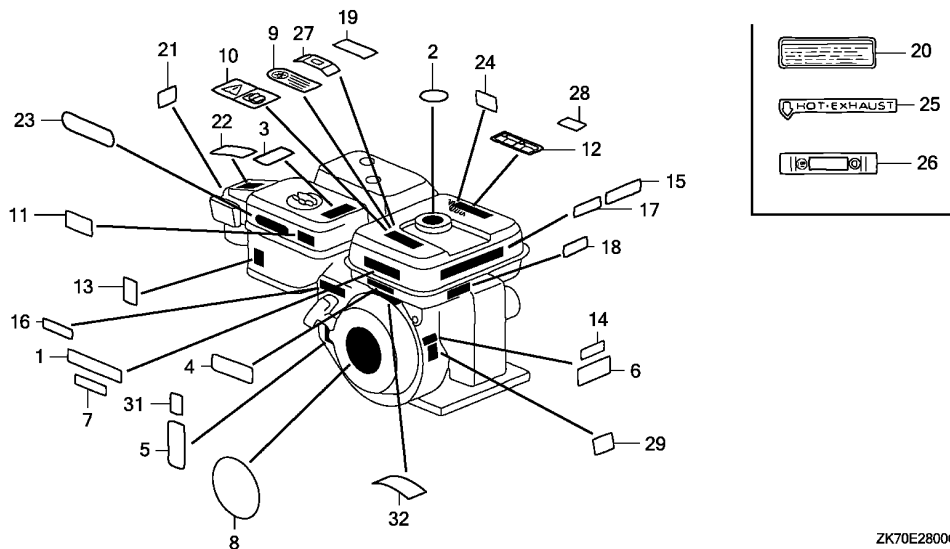

ZK70E2800C

Ref. No.	Part No.	Description	Reqd. QTY				Serial No.	Parts catalogue code
			(1)	GX120K1 (2)	(3)	(4)		
13)	87528-733-E91	MARK, CHOKE (H=34)	1	-	-	-	KRS5, KRS6, SAR4	
			1	-	-	4335504	DKR, HHQ4, HX4, KRA4, KRF4, KRS4, KRT4, LAJ4, LHQ4, LJD2, LSJ4, LX4, QHQ4, QLL, QMA4, QMA8, QME4, QWA4, QX4, QX7, RD4, RHC, RHQ4, RX4, SAJ4, SD4, SE, SG24, SHQ4, SJD2, SMA7, SM14, SSX4, SWX4, SXS4, SX4, SX7, TX4, VEX, VEX7, VMS4, VX4, VX7, WKT4, WMA3, WME4	
			1	-	-	4453887	SWX2	
			1	-	-	4550192	WMK	
	87528-ZH7-000	MARK, CHOKE (GRAY)	1	-	-	4335504	4550192 WM1	
			1	-	-	4462600	ARL, WMA4	
			1	-	-	4550193	HX2	
			1	-	-		WMK, WM1	
14	87530-ZH7-010	LABEL, SPECIFICATION (INTERNAL)	1	-	-	-	SAJ, SCJ, SJ, SJC1, SJC5, SKR, SMJ, SM11, SSK1, SSK3, STP, STS, VET, WJ, WJP	
			1	-	-	4512524	SYA	
	87530-ZH7-821	LABEL, SPECIFICATION (INTERNAL/L-TYPE)	-	1	-	-		
15	87532-ZB4-H50	MARK, OIL ALERT (FRENCH)	1	-	-	-	HX26, QX26, TX26, VED6, WKD6, WKT6	
			-	(1)	-	-		
16	87532-ZH8-W40	MARK, THROTTLE INDICATION	1	-	-	-	HHQ4, HX4, KRT4, LAJ4, LHQ4, LSJ4, LX4, QHQ4, QLL, QMA4, QMA8, QME4, QWA4, QX4, QX7, RD4, RHC, RHQ4, RX4, SAJ4, SAR4, SD4, SE, SG24, SHQ4, SMA7, SM14, SSX4, SWX4, SXS4, SX4, SX7, TX4, VX4, VX7, WKT4, WMA3, WME4, WMK	
			1	-	-	4453887	SWX2	
	87532-ZH7-000		1	-	-	-	WMA4	
17	87532-ZH8-000	MARK, OIL ALERT (INTERNAL)	1	-	-	-	LJC, SJC1, SJC5, SMJ, VEE1	
			-	1	-	-		

Ref. No.	Part No.	Description	Reqd. QTY				Serial No.	Parts catalogue code
			(1)	GX120K1 (2)	(3)	(4)		
17)	87532-ZH8-810	MARK, OIL ALERT (EXTERNAL) ..	1	-	-	-	HTF2, HX, HXU, HX2, HX26, LJC8, LX, LXU, LX2, PX, PX2, QMX2, QWA4, QX, QXC9, QXS2, QXU, QX2, QX26, RX, SG24, SMW2, SM12, SSX2, SWX2, SX, SXS4, TX, TX2, TX26, UXU, VED1, VED6, VSX, VSX1, VX, VXU, WKD6, WKT2, WKT6, WME2	
	87532-ZK7-800	MARK, OIL ALERT	-	1	-	-	QXBR, TXBR, VXBR	
18	87532-ZH8-810	MARK, OIL ALERT (EXTERNAL) ..	1	-	-	-	VSX, VSX1	
19	87532-ZH8-810	MARK, OIL ALERT (EXTERNAL) ..	1	-	-	-	WME2	
20	87533-ZC0-630	MARK, AIR CLEANER	1	-	-	-	VMT	
21	87534-ZE1-000	LABEL, AIR CLEANER CAUTION ..	-	(1)	-	-		
22	87534-ZE1-841	LABEL, AIR CLEANER CAUTION ..	1	-	-	-	QXC9	
23	87535-ZE1-841	MARK, AIR CLEANER SALES POINT	1	-	-	-	QXC9	
24	87539-737-J00	MARK, HEAT CAUTION	1	-	-	-	VEK	
25	87539-898-620	MARK, EX. CAUTION (ENGLISH/FRENCH)	1	-	-	-	VMT	
26	87565-ZB4-A00	PLATE, FUEL INDICATION	1	-	-	-	LTR, VMT	
27	87565-ZE2-A01	MARK, FUEL INDICATION (PICTOGRAPH)	1	-	-	-	VEK	
	87565-ZE2-000	MARK, FUEL INDICATION (JAPANESE)	1	-	-	-	SKR, SMJ	
28	87593-737-J00	MARK, USE FUEL	1	-	-	-	VEK	
29	87594-ZH7-B20	MARK, OIL CAUTION	1	-	-	-	VEK	
31	87114-ZH7-000	LABEL, WARNING (NOT CERTIFIED FOR SALE)	1	-	-	-	ARL, WMA4, WMK	
			1	-	-	4452742	HX, KR, KRT, KRT6, LAJ, LD, LH, LJ, LJC, LJS, LSJ, LTK1, LTR, LTS, LX, PX, QD, QH, QM, QT, QX, RD, RX, SAJ, SD, SH, SJ, SJC5, SKR, SMJ, SM11, SX, TX, VEE1, VEK, VET, VMT, VX, WJ, WM1	
			1	-	-	4497136	DS, LJC8, LTJ, QA, SCJ, SJC1, SSK1, STP, STS, VED, VED1, VSX, VSX1, WJP	
			1	-	-	4508213	SSK3	
			-	1	-	4452742		
32	87516-ZM7-801	MARK, OPERATOR CAUTION	1	-	-	-	WMA4	

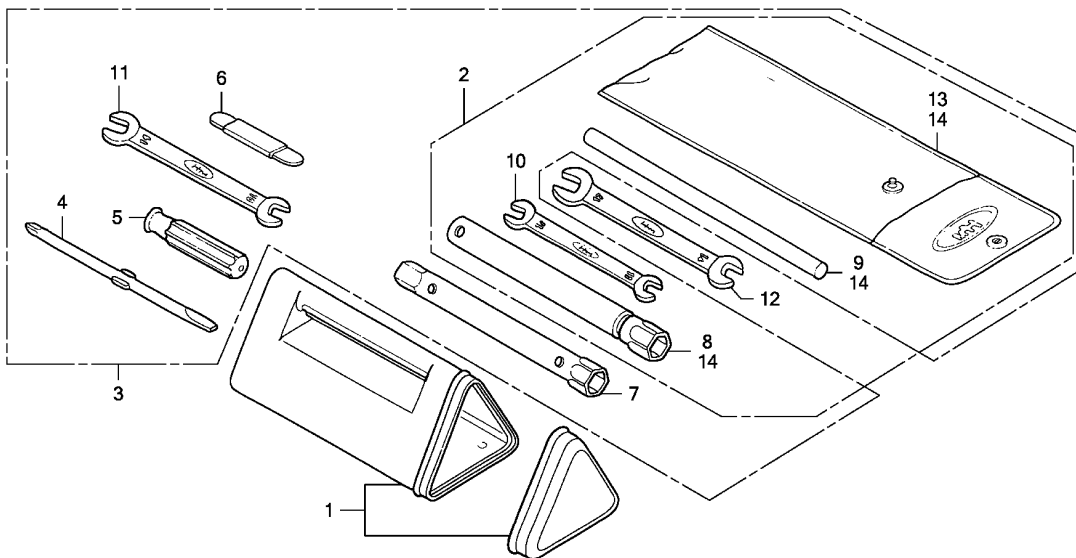

ZK70E2900A

Ref. No. L.O.N. (Relative ref. Number) Description F.R.T.

NO INFORMATION

Ref. No.	Part No.	Description	Reqd. QTY				Serial No.	Parts catalogue code
			(1)	(2)	(3)	(4)		
1	83501-ZF1-000	BOX, TOOL	1	-	1	-	-----	QT,SIH
2	89000-ZE1-000	TOOL KIT	1	-	-	-	-----	QM
3	89001-ZF1-000	BAG SET, TOOL	-	(1)	-	-	-----	
4	89102-538-000	DRIVER, SCREW (NO.2 + -)	1	-	-	-	-----	QT
5	89103-538-000	GRIP	1	-	-	-	-----	QT
6	89210-ZF1-000	GAUGE ASSY., THICKNESS	1	-	-	-	-----	QT
7	89216-ZF1-000	WRENCH, BOX	1	-	-	-	-----	QT
	89216-ZH8-S00	WRENCH, PLUG	-	-	1	-	-----	
8	89218-ZE1-000	WRENCH COMP., SPARK PLUG	1	-	-	-	-----	AR,ARL,DKR,DS,KR,KRA4,KRF4,KRS4,KRS5,KRS6,KRT,KRT4,KRT6,LAJ LAJ4,LJ,LJC,LJC8,LJS,LSJ,LSJ4,LTJ,LTK1,LTR,LTS,QM,QMA8,QMX2,QT QWA4,RHC,SAJ,SAJ4,SAR4,SCJ,SJ,SJC1,SJC5,SKR,SMA7,SMJ,SMW2,SM11 SM12,SM14,SSK1,SSK3,SSX2,SSX4,STP,STS,VED,VED1,VED6,VEE1,VEK VET,VSX,VSX1,WDA6,WD12,WJ,WJP,WKD6,WKT2,WKT4,WKT6,WMA3,WMA4 WME2,WME4,WMK,WM1
			(1)	-	-	-	-----	QA,QA2,QXC9
			-	(1)	-	-	-----	
	99004-21001	WRENCH, BOX (P21)	1	-	1	-	2329687	SIH,WIH
9	89219-805-000	HANDLE, BOX WRENCH	1	-	-	-	-----	VMT
			-	(1)	1	-	-----	QM,QT,VEK
10	99001-10120	SPANNER, 10X12	1	-	-	-	-----	QM,QT
			-	(1)	-	-	-----	
11	99001-10140	SPANNER, 10X14	1	-	-	-	-----	QT
12	99001-14170	SPANNER, 14X17	1	-	-	-	-----	QM
			-	(1)	-	-	-----	

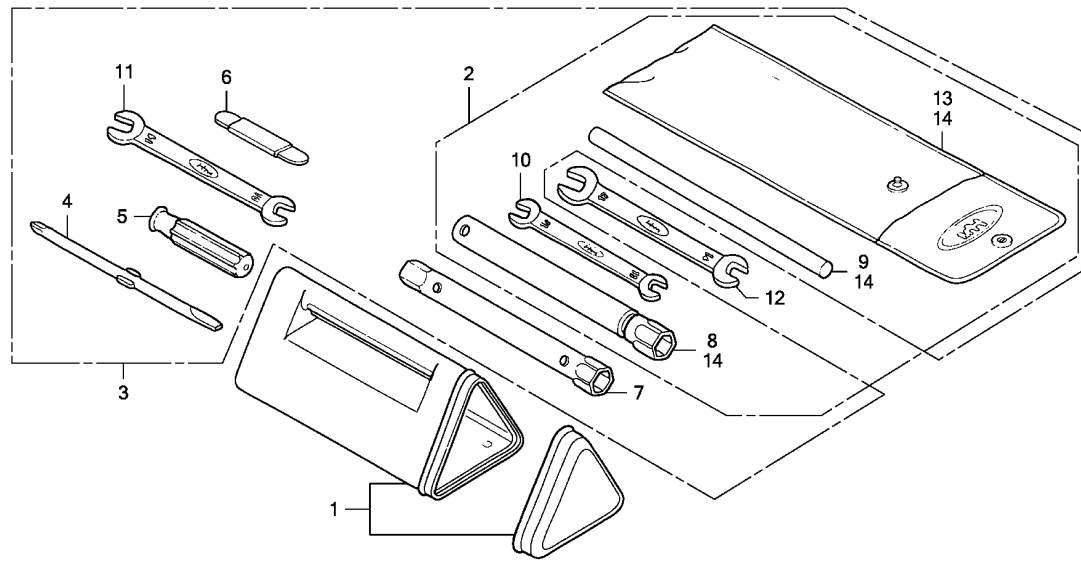

ZK70E2900A

Ref. No.	Part No.	Description	Reqd. QTY				Serial No.	Parts catalogue code
			(1)	GX120K1 (2)	(3)	(4)		
13	99008-02300	BAG, TOOL, 230MM	1	-	1	-	-----	QM,QT,SIH,WIH
14	89000-ZH7-T00	TOOL KIT	-	(1)	-	-	-----	SIH,WIH



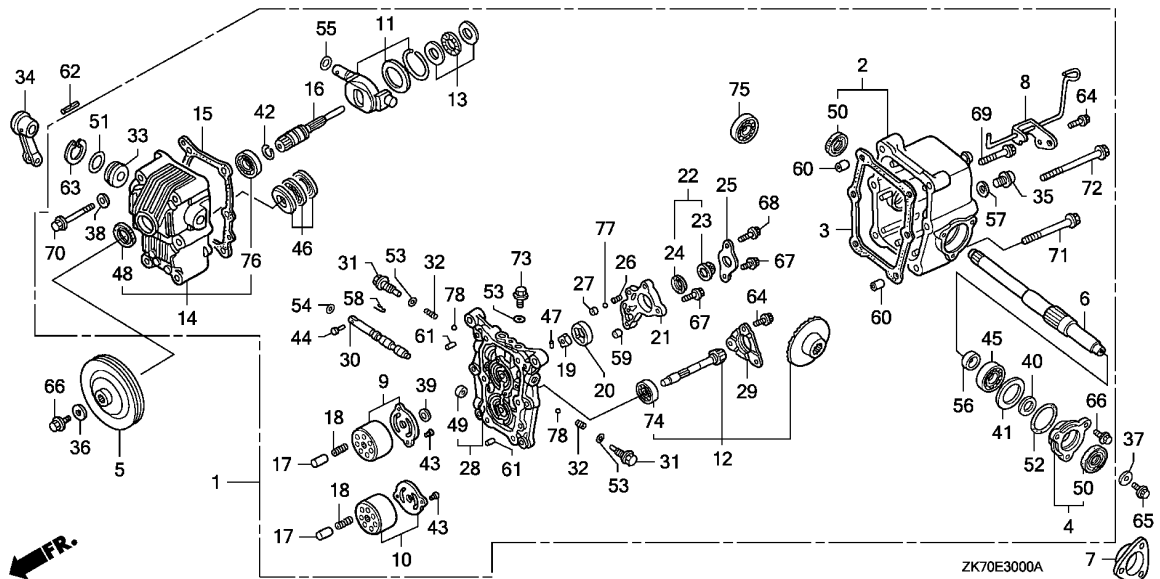

Ref. No.	L.O.N.	(Relative ref. Number) Description	F.R.T.
2	8141L8	CASE, HYDROSTATIC TRANSMISSION :REAR	0.5
3	8141L7	PACKING, HYDROSTATIC TRANSMISSION CASE :REAR	0.4
6	8141D5	SHAFT, CROSS	0.5
8	8141A0	ARM, NEUTRAL VALVE	0.1
9		(17,18)	
	8141L1	PLATE SET, HYDROSTATIC PUMP CYLINDER	0.4
10		(17,18)	
	8141L2	PLATE SET, HYDROSTATIC MOTOR CYLINDER	0.4
11		(55)	
	8141A5	BOWL SET, CONTROL	0.4
12	8141C1	SHAFT, MOTOR AND GEAR SET, BEVEL	0.5
13	8141A1	BEARING SET, THRUST NEEDLE	0.4
14	8141L3	CASE, HYDROSTATIC TRANSMISSION PUMP	0.4
15	8141K6	PACKING, HYDROSTATIC TRANSMISSION PUMP CASE	0.3
16	8141L5	SHAFT, HYDROSTATIC TRANSMISSION PUMP	0.5

Ref. No.	Part No.	Description	Reqd. QTY				Serial No.	Parts catalogue code
			(1)	GX120K1 (2)	(3)	(4)		
1	20001-VD6-R00	TRANSMISSION ASSY.	1	-	-	-	SSK3	
2	21210-VD6-854	CASE COMP., RR. TRANSMISSION	1	-	-	-	SSK3	
3	21215-VD6-851	PACKING, RR. TRANSMISSION CASE	1	-	-	-	SSK3	
4	21225-VD6-853	HOLDER COMP., OIL SEAL	1	-	-	-	SSK3	
5	22423-767-000	PULLEY, WHEEL DRIVEN (133MM)	1	-	-	-	SSK3	
6	23236-VD6-871	SHAFT, CROSS	1	-	-	-	SSK3	
7	23384-767-000	HOLDER, BEARING	1	-	-	-	SSK3	
8	24176-VD6-852	ARM COMP., NEUTRAL VALVE	1	-	-	-	SSK3	
9	25010-VD6-851	PLATE SET, PUMP CYLINDER	1	-	-	-	SSK3	
10	25011-VD6-851	PLATE SET, MOTOR CYLINDER	1	-	-	-	SSK3	
11	25012-VD6-850	BOWL SET, CONTROL	1	-	-	-	SSK3	
12	25013-VD6-850	GEAR SET, MOTOR SHAFT & BEVEL	1	-	-	-	SSK3	
13	25014-VD6-850	BEARING SET, THRUST NEEDLE ..	1	-	-	-	SSK3	
14	25310-VD6-M50	CASE COMP., PUMP (VR30)	1	-	-	-	SSK3	
15	25312-VD6-851	PACKING, PUMP CASE	1	-	-	-	SSK3	
16	25321-VD6-852	SHAFT, PUMP	1	-	-	-	SSK3	
17	25342-773-003	PISTON, PUMP (HOLE DEPTH=18MM)	14	-	-	-	SSK3	
18	25343-773-000	SPRING, PISTON (5.8X34.5)	14	-	-	-	SSK3	
19	25411-VD6-852	ROTOR, TROCHOID	1	-	-	-	SSK3	
20	25415-VD6-851	VANE, TROCHOID	1	-	-	-	SSK3	
21	25416-VD6-853	HOUSING, TROCHOID	1	-	-	-	SSK3	
22	25420-VD6-852	FILTER ASSY., SUCTION	1	-	-	-	SSK3	
23	25421-VD6-852	FILTER, SUCTION	1	-	-	-	SSK3	
24	25422-VD6-851	SEAL, RUBBER	1	-	-	-	SSK3	
25	25425-VD6-852	PLATE, FILTER CAP	1	-	-	-	SSK3	

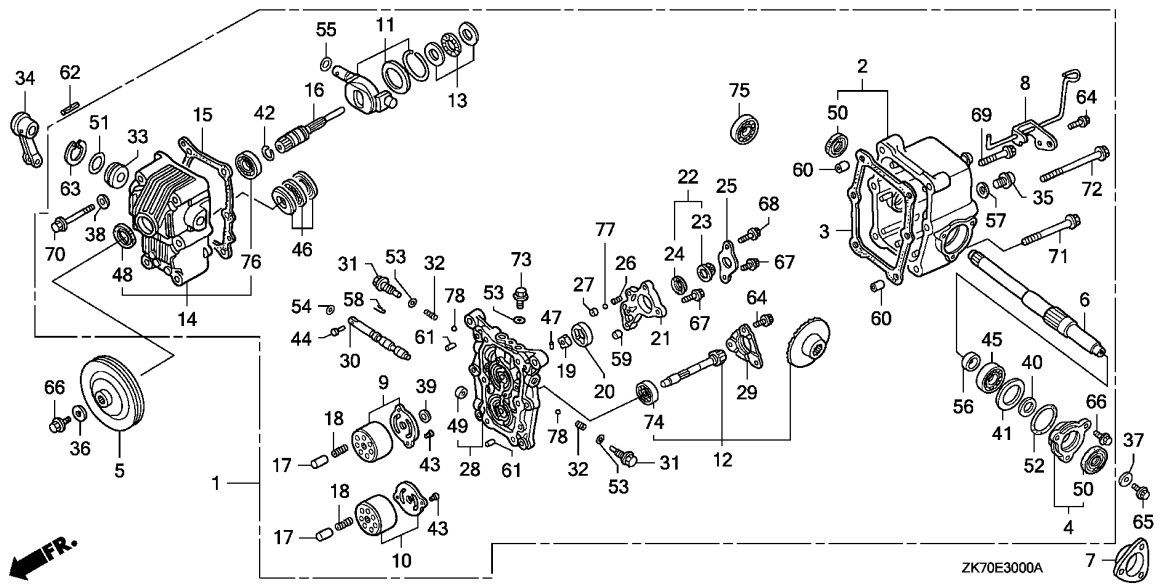

Ref. No.	L.O.N.	(Relative ref. Number) Description	F.R.T.
21	8141L6	(19,20,26,27,47,77) HOUSING, HYDROSTATIC TRANSMISSION TROCHOID	0.5
22	8141A9	(23,24) FILTER, SUCTION	0.4
28	8141C8	PLATE, HYDROSTATIC DISTRIBUTOR (54)	0.6
30	8141N5	SPOOL, HYDROSTATIC TRANSMISSION NEUTRAL VALVE ..	0.2
32	8141N6	SPRING, HYDROSTATIC DISTRIBUTOR CHECK VALVE	0.2
45	8141N4	BEARING, CROSS SHAFT :LEFT ...	0.4
46	8141M5	BEARING, THRUST BALL	0.4
48	8141M8	OIL SEAL, HYDROSTATIC TRANSMISSION PUMP SHAFT	0.4
50	8141N7	OIL SEAL, CROSS SHAFT :LEFT ..	0.3
	8141N8	OIL SEAL, CROSS SHAFT :RIGHT ..	0.5
74	8141A3	BEARING, HYDROSTATIC TRANSMISSION PINION MOTOR SHAFT	0.5
75	8141A2	BEARING, CROSS SHAFT :RIGHT ..	0.5
76	8141M9	BEARING, HYDROSTATIC TRANSMISSION PUMP SHAFT	0.4

Ref. No.	Part No.	Description	Reqd. QTY				Serial No.	Parts catalogue code
			(1)	(2)	(3)	(4)		
26	25431-VD6-851	SPRING, RELIEF VALVE	1	-	-	-	SSK3	
27	25437-VD6-852	SEAT, RELIEF VALVE	1	-	-	-	SSK3	
28	25510-VD6-854	PLATE COMP., DISTRIBUTOR	1	-	-	-	SSK3	
29	25518-VD6-850	HOLDER, BEARING	1	-	-	-	SSK3	
30	25521-VD6-850	SPOOL, NEUTRAL VALVE	1	-	-	-	SSK3	
31	25525-773-000	BOLT, CHECK VALVE	2	-	-	-	SSK3	
32	25526-VD6-851	SPRING, CHECK VALVE	2	-	-	-	SSK3	
33	25813-773-000	BUSH, CONTROL BOWL (B)	1	-	-	-	SSK3	
34	40311-767-000	ARM, CLUTCH	1	-	-	-	SSK3	
35	90081-MC7-000	BOLT, PLUG, 14MM	1	-	-	-	SSK3	
36	90417-115-000	WASHER, CAMSHAFT SIDE	1	-	-	-	SSK3	
37	90474-704-000	WASHER, 6X17	1	-	-	-	SSK3	
38	90503-VD6-850	WASHER, SEALING, 9X16X1.5	6	-	-	-	SSK3	
39	90504-VD6-851	WASHER, THRUST, 8MM	1	-	-	-	SSK3	
40	90508-VD6-850	WASHER, PLAIN, 15MM	1	-	-	-	SSK3	
41	90565-VD6-852	SHIM A, BEVEL GEAR (1.5MM) ..	1	-	-	-	SSK3	
	90566-VD6-852	SHIM B, BEVEL GEAR (1.55MM) ..	1	-	-	-	SSK3	
	90567-VD6-852	SHIM C, BEVEL GEAR (1.6MM) ..	1	-	-	-	SSK3	
	90568-VD6-852	SHIM D, BEVEL GEAR (1.65MM) ..	1	-	-	-	SSK3	
	90569-VD6-851	SHIM E, BEVEL GEAR (1.7MM) ..	1	-	-	-	SSK3	
	90570-VD6-852	SHIM F, BEVEL GEAR (1.75MM) ..	1	-	-	-	SSK3	
42	90663-VD6-850	CLIP, BEARING	1	-	-	-	SSK3	
43	90755-VD6-900	DOWEL PIN, 3X5.8	4	-	-	-	SSK3	
44	90759-VD6-850	PIN, NEUTRAL VALVE	1	-	-	-	SSK3	
45	91007-MN5-003	BEARING, RADIAL BALL, 6904	1	-	-	-	SSK3	
	(NTN)		1	-	-	-	SSK3	



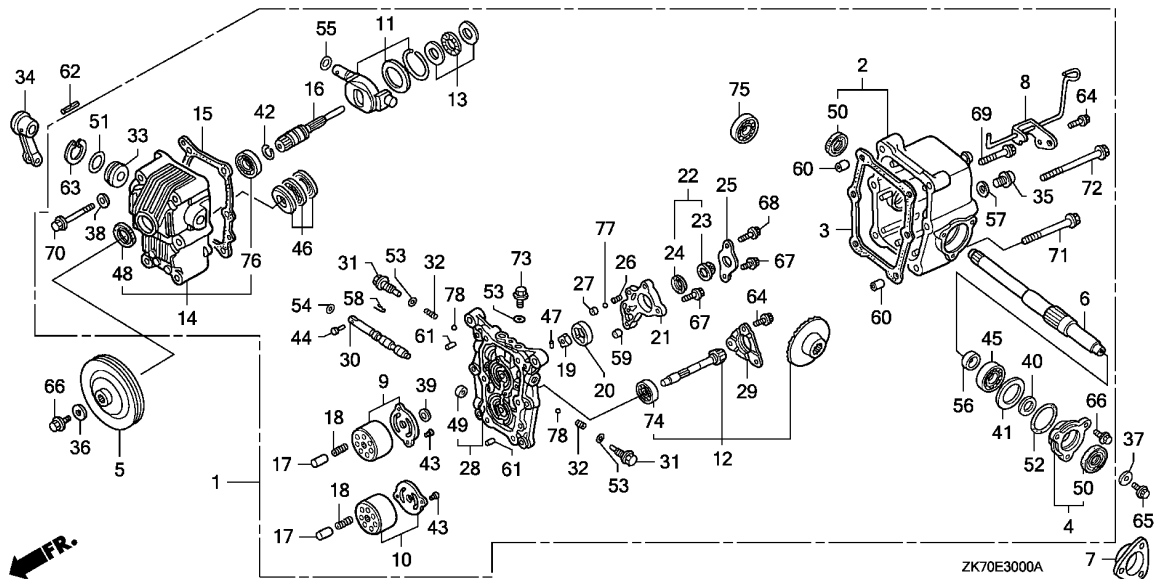

Ref. No.	Part No.	Description	Reqd. QTY				Serial No.	Parts catalogue code
			(1)	GX120K1 (2)	(3)	(4)		
46	91069-VD6-851	BEARING, THRUST BALL, 51204	1	-	-	-	SSK3	
47	91151-VD6-851	ROLLER, 2.5X11.8	1	-	-	-	SSK3	
48	91202-722-003	OIL SEAL, 17X30X6	1	-	-	-	SSK3	
49	91255-VD6-851	DUST SEAL, 9X15X5	1	-	-	-	SSK3	
50	91272-733-931	OIL SEAL, 15X28X7	2	-	-	-	SSK3	
51	91304-GB1-900	O-RING, 25X2.4	1	-	-	-	SSK3	
52	91352-VD6-851	O-RING, 34.6X1.9	1	-	-	-	SSK3	
53	91355-VD6-852	O-RING, 11X1.9	4	-	-	-	SSK3	
54	91360-VD6-851	O-RING, 5.8X1.9	1	-	-	-	SSK3	
55	91361-VD6-901	O-RING, 11.8X1.9	1	-	-	-	SSK3	
56	91589-VD6-851	COLLAR, BEVEL GEAR	1	-	-	-	SSK3	
57	94109-14000	WASHER, DRAIN PLUG, 14MM	1	-	-	-	SSK3	
58	94251-04000	PIN, LOCK, 4MM	1	-	-	-	SSK3	
59	94301-08100	DOWEL PIN, 8X10	2	-	-	-	SSK3	
60	94301-10120	DOWEL PIN, 10X12	2	-	-	-	SSK3	
61	94302-05080	PIN B, DOWEL, 5X8	2	-	-	-	SSK3	
62	94305-40282	PIN, SPRING, 4X28	1	-	-	-	SSK3	
63	94520-30000	CIRCLIP, INTERNAL, 30MM	1	-	-	-	SSK3	
64	95701-06012-08	BOLT, FLANGE, 6X12	4	-	-	-	SSK3	
65	95701-06016-00	BOLT, FLANGE, 6X16	1	-	-	-	SSK3	
66	95701-06016-08	BOLT, FLANGE, 6X16	4	-	-	-	SSK3	
67	95701-06025-08	BOLT, FLANGE, 6X25	2	-	-	-	SSK3	
68	95701-06032-00	BOLT, FLANGE, 6X32	1	-	-	-	SSK3	
69	95701-08045-08	BOLT, FLANGE, 8X45	2	-	-	-	SSK3	
70	95701-08065-00	BOLT, FLANGE, 8X65	6	-	-	-	SSK3	

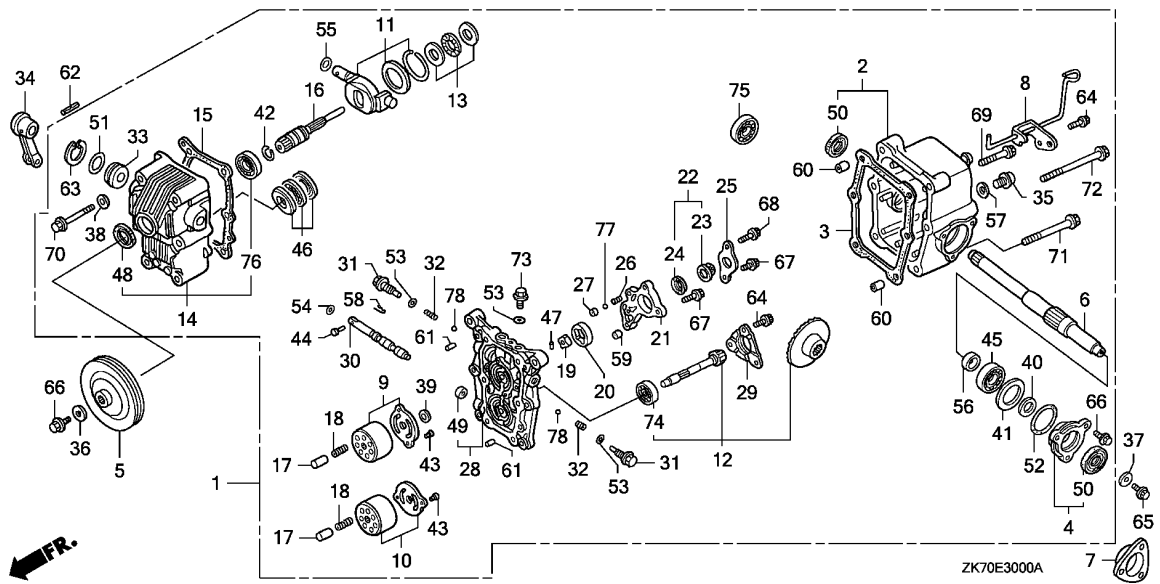

Ref. No.	Part No.	Description	Reqd. QTY				Serial No.	Parts catalogue code
			(1)	GX120K1 (2)	(3)	(4)		
71	95701-08070-08	BOLT, FLANGE, 8X70	2	-	-	-	SSK3	
72	95701-08090-08	BOLT, FLANGE, 8X90	2	-	-	-	SSK3	
73	95701-10016-00	BOLT, FLANGE, 10X16	2	-	-	-	SSK3	
74	96100-60010-00	BEARING, RADIAL BALL, 6001 ..	1	-	-	-	SSK3	
75	96100-60020-00	BEARING, RADIAL BALL, 6002 ..	1	-	-	-	SSK3	
76	96100-60030-00	BEARING, RADIAL BALL, 6003 ..	1	-	-	-	SSK3	
77	96211-06000	BALL, STEEL, #6 (3/16)	1	-	-	-	SSK3	
78	96211-08000	BALL, STEEL, #8 (1/4)	2	-	-	-	SSK3	



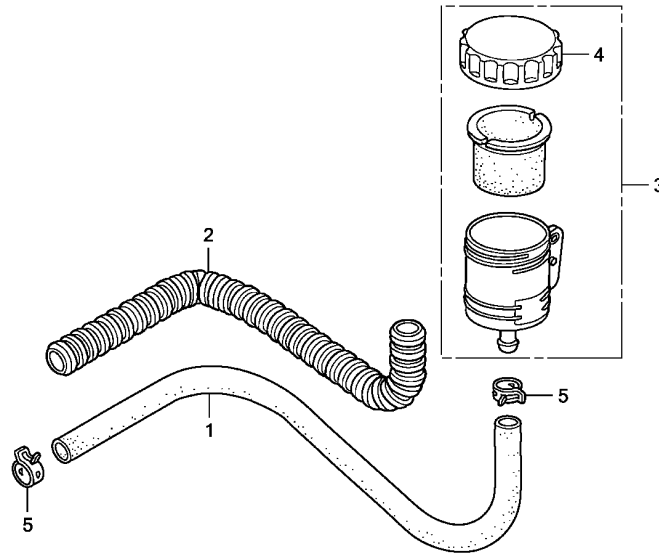

ZK70E3100A

Ref. No.	L.O.N.	(Relative ref. Number) Description	F.R.T.
----------	--------	------------------------------------	--------

NO INFORMATION

Ref. No.	Part No.	Description	Reqd. QTY				Serial No.	Parts catalogue code
			(1)	GX120K1 (2)	(3)	(4)		
1	15422-767-000	TUBE, OIL	1	-	-	-	SSK3	
2	15428-767-000	PROTECTOR, OIL TUBE	1	-	-	-	SSK3	
3	56850-767-000	TANK ASSY., OIL	1	-	-	-	SSK3	
4	56862-767-300	BODY, OIL CAP	1	-	-	-	SSK3	
5	91462-SA5-950	CLAMP D, 19MM	2	-	-	-	SSK3	

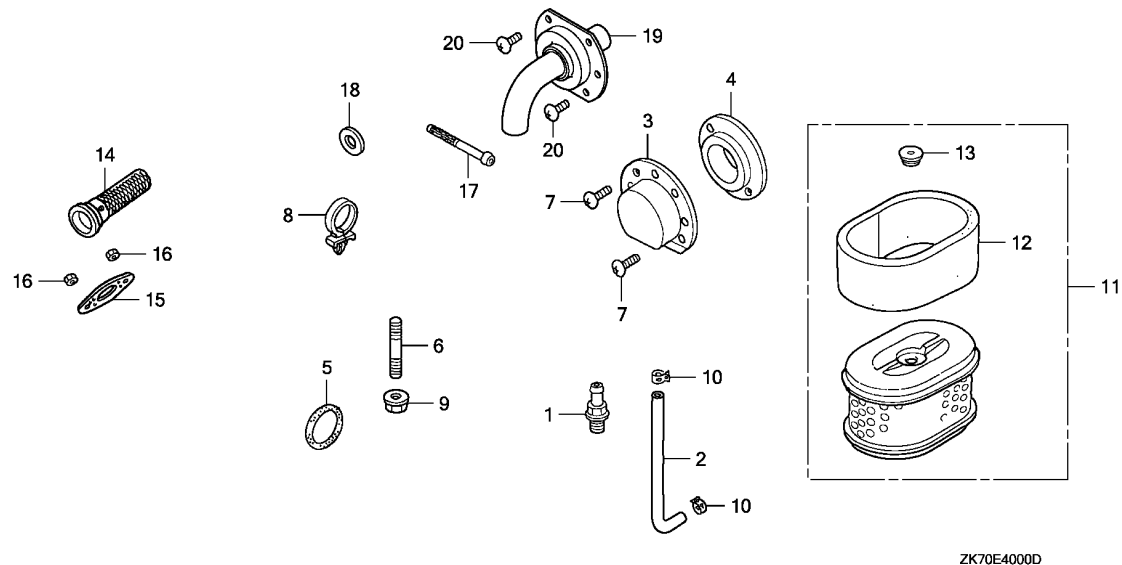

ZK70E4000D

Ref. No.	L.O.N.	(Relative ref. Number) Description	F.R.T.
----------	--------	------------------------------------	--------

NO INFORMATION

Ref. No.	Part No.	Description	Reqd. QTY				Serial No.	Parts catalogue code
			(1)	(2)	(3)	(4)		
1	15550-ZK8-P90	JOINT, DRAIN	1	-	-	-	SYA	
2	15552-ZB9-000 15552-ZK7-S90	TUBE, DRAIN	1	-	-	-	SM11, SM12, SM14 SM11, SM12, SM14 SYA	
3	18340-ZE1-010	DEFLECTOR COMP.	1	-	-	-	SWX2, SWX4	
4	18522-ZE1-000	GUIDE, MUFFLER	1	-	-	-	SWX2, SWX4	
5	78118-YB0-003	RING, SEAL (B)	2	-	-	-	WJP, WME4	
6	90001-ZK7-V00 90002-ZK7-V00	BOLT, STUD, 10X32	3	-	-	-	AR, ARL, DKR, KR, KRA4, KRF4, KRS4, KRS5, KRS6 AR, ARL, DKR, KR, KRA4, KRF4, KRS4, KRS5, KRS6	
7	90002-ZG0-003	SCREW, TAPPING, 4X8	2	-	-	-	SWX2, SWX4	
8	90617-SAO-003	CLIP, WIRE HARNESS	1	-	-	-	KRS4	
9	94050-10000	NUT, FLANGE, 10MM	4	-	-	-	AR, ARL, DKR, KR, KRA4, KRF4, KRS4, KRS5, KRS6	
10	95002-41200-08	CLAMP, TUBE (D12)	2	-	-	-	SM11, SM12, SM14, SYA	
11	17210-ZE1-822	ELEMENT, AIR CLEANER (DUAL) ..	1	-	-	-	KRS6	
12	17218-ZE1-821	FILTER, OUTER	1	-	-	-	KRS6	
13	17232-891-000	GROMMET, AIR CLEANER	1	-	-	-	KRS6	
14	18355-ZE1-810	ARRESTER, SPARK (SILENT)	1	-	-	-	VPM4	
15	18381-ZH8-800	GASKET, MUFFLER	1	-	-	-	SYA, VPM4	
16	94001-08000-0S	NUT, HEX., 8MM	2	-	-	-	SYA, VPM4	
17	16952-ZE6-000	STRAINER, FUEL	1	-	-	-	SYA	
18	90601-ZE1-000	WASHER, DRAIN PLUG, 10.2MM ..	1	-	-	-	SYA	
19	18340-ZH7-U20	DEFLECTOR COMP.	1	-	-	-	LTS	
20	90055-ZE1-000	SCREW, TAPPING, 4X6	2	-	-	-	LTS	



E-40-1

OTHER PARTS(2)

K15

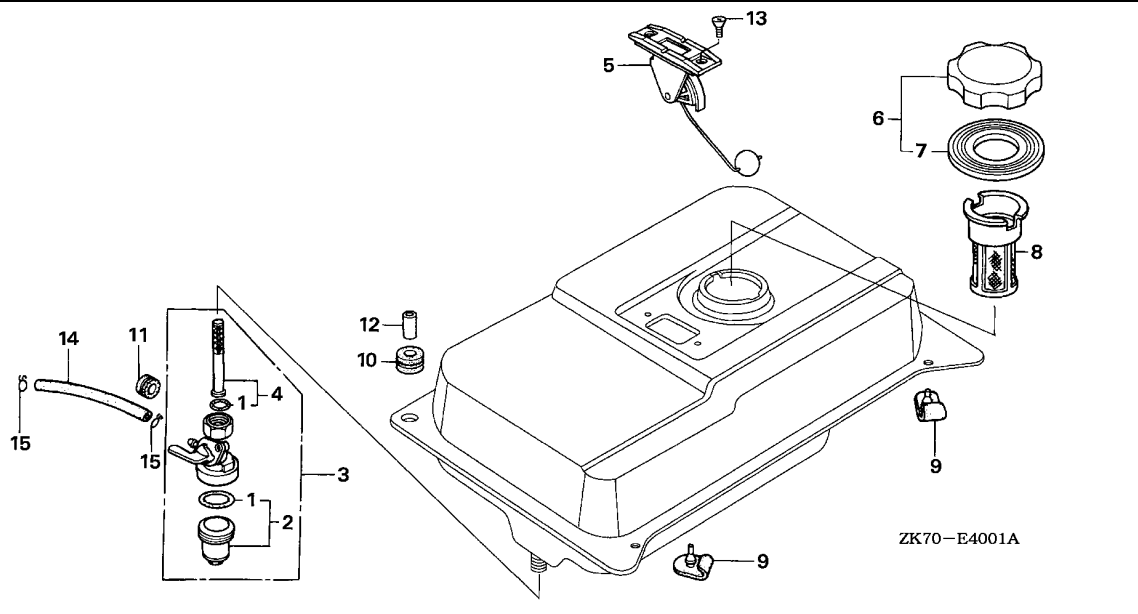

Ref. No.	L.O.N.	(Relative ref. Number) Description	F.R.T.
1	3101C4	PACKING SET, FUEL TANK COCK ..	0.2
2	3101F4	CUP, FUEL STRAINER	0.2
3	3101A3	COCK, FUEL	0.2
4	3101D5	SCREEN, FUEL STRAINER	0.2
5	6171A1	METER/GAUGE UNIT, FUEL	0.1
8	3101A6	FILTER, FUEL	0.1
10	3101M4	RUBBER, TANK SETTING	0.1
14	3101F2	TUBE, FUEL COCK	0.2

Ref. No.	Part No.	Description	Reqd. QTY				Serial No.	Parts catalogue code
			(1)	GX120K1 (2)	(3)	(4)		
1	16080-898-631	O-RING	1	-	-	-	VMT	
2	16081-471-831	CUP, FUEL STRAINER	1	-	-	-	VMT	
3	16950-898-633	COCK ASSY., FUEL	1	-	-	-	VMT	
4	16952-GG2-731	SCREEN SET	1	-	-	-	VMT	
5	17505-ZB2-003	METER ASSY., FUEL	1	-	-	-	VMT	
6	17620-Z0T-305	CAP COMP., FUEL FILLER (CHROME PLATED)	1	-	-	-	VMT	
7	17631-Z0T-812	PACKING, FUEL FILLER CAP (39X62X3)	1	-	-	-	VMT	
8	17672-ZE2-W01	FILTER, FUEL	1	-	-	-	VMT	
9	50319-ZB2-000	RUBBER, TANK MOUNTING	2	-	-	-	VMT	
10	90852-898-000	RUBBER, CONTROL BOX	2	-	-	-	VMT	
11	90854-ZB3-000	RUBBER, FUEL (9X15X20)	1	-	-	-	VMT	
12	91552-898-000	COLLAR, CONTROL BOX	2	-	-	-	VMT	
13	93600-05010-0A	SCREW, FLAT, 5X10	2	-	-	-	VMT	
14	95001-45250-40	TUBE, FUEL, 4.5X250 (95001-45001-60M)	1	-	-	-	VMT	
15	95002-02080	CLIP, TUBE (B8)	2	-	-	-	VMT	

2

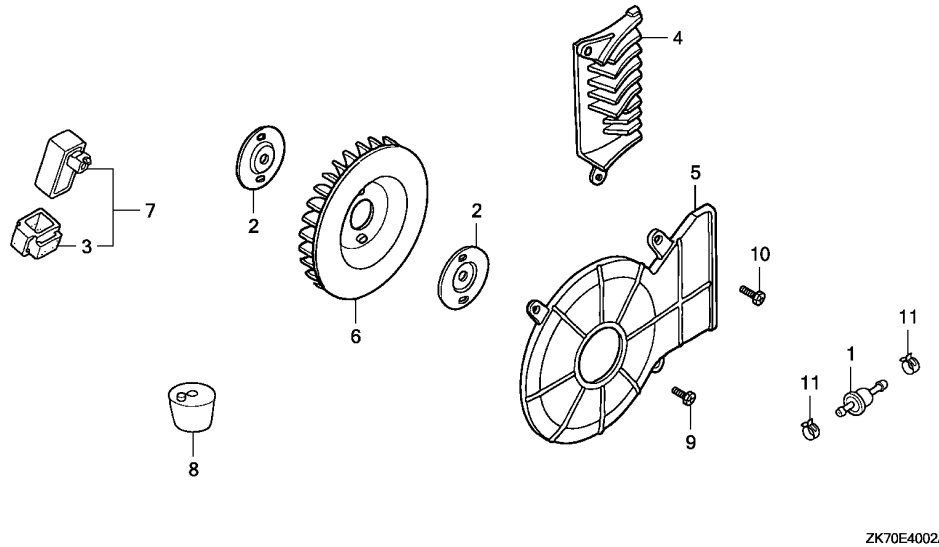

Ref. (Relative ref. Number)
No. L.O.N. Description F.R.T.

NO INFORMATION

Ref. No.	Part No.	Description	Reqd. QTY				Serial No.	Parts catalogue code
			(1)	GX120K1 (2)	(3)	(4)		
1	16910-GB2-005	STRAINER COMP., FUEL	1	-	-	-	AR,ARL,KR,KRA4,KRF4,KRT,KRT4,KRT6	
2	19512-ZA8-000	PLATE, FAN SETTING	2	-	-	-	VEE1	
3	30401-GA7-000	CUSHION, C.D.I. UNIT	1	-	-	-	SKR	
4	31107-ZC0-003	GUIDE, GENERATOR AIR	1	-	-	-	VEE1	
5	31109-ZC0-003	COVER, GENERATOR FAN	1	-	-	-	VEE1	
6	31112-ZC0-003	FAN, COOLING	1	-	-	-	VEE1	
7	34100-735-J10	CONTROL UNIT, ENGINE	1	-	-	-	SKR	
8	60407-812-000	RUBBER, BOTTOM	4	-	-	-	LJC,LJC8	
9	90031-ZA1-003	SCREW, TAPPING, 5X14	1	-	-	-	VEE1	
10	90031-ZC0-003	SCREW, TAPPING, 5X18	2	-	-	-	VEE1	
11	95002-40850-08	CLAMP, TUBE (D8.5)	2	-	-	-	AR,ARL,KR,KRA4,KRF4,KRT,KRT4,KRT6	

E-40-3

OTHER PARTS(4)

L 1

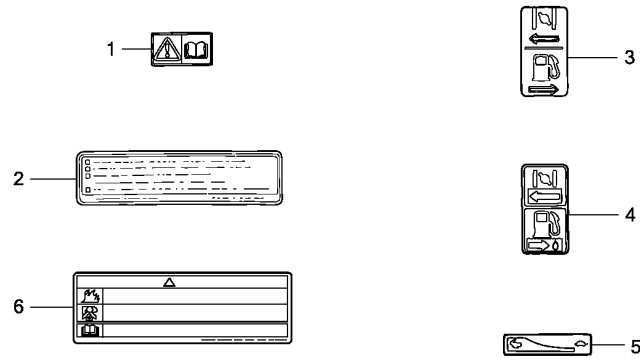

ZK70E4003A

Ref. No. L.O.N. (Relative ref. Number) Description F.R.T.

NO INFORMATION

Ref. No.	Part No.	Description	Reqd. QTY				Serial No.	Parts catalogue code
			(1)	GX120K1 (2)	(3)	(4)		
1	87522-ZH8-W41	MARK, CAUTION (PICTOGRAPH) ..	1	-	-	-	HT24	
2	87522-ZH9-010	LABEL, CAUTION (ENGLISH, ETC.)	1	-	-	4462600	HX2,SJD2	
3	87528-ZE1-810	MARK, CHOKE	1	-	-	4462600	HT24	
4	87528-ZH7-000	MARK, CHOKE (GRAY)	1	-	-	4462600	HX2	
5	87528-733-E91	MARK, CHOKE (H=34)	1	-	-	-	HT24	
5	87532-ZH8-W40	MARK, THROTTLE INDICATION ...	1	-	-	4462600	HT24	
6	87516-ZM7-801	MARK, OPERATOR CAUTION	1	-	-	-	HX2,SJD2	
							ARL	

2

EOP-1

GASKET KIT

L 2

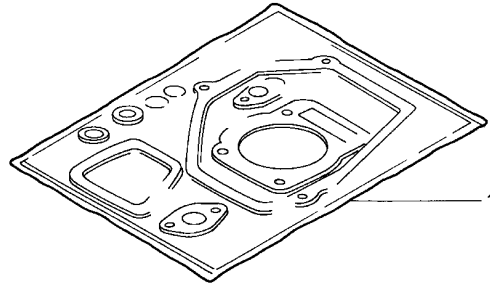

HENG-X0003

Ref. L.O.N. (Relative ref. Number) F.R.T.
No. Description

NO INFORMATION

Ref. No.	Part No.	Description	Reqd. QTY				Serial No.	Parts catalogue code
			(1)	GX120K1 (2)	(3)	(4)		
1	061A1-ZH7-010	GASKET KIT	-	1	-	-	----- H1,Q1,R1,W1	
	061A1-ZH7-700	-	1	-	-		
	061A1-ZH7-710	-	1	-	-		
	061A1-ZH7-720	-	1	-	-		
	06111-ZK7-U30	1	-	-	-	----- AR,ARL	
	06111-ZK7-V00	1	-	-	-	----- KR,KRA4,KRF4	

2

PART NO. INDEX



Part Number	Address	Page	Ref.	Part Number	Address	Page	Ref.	Part Number	Address	Page	Ref.	Part Number	Address	Page	Ref.
06000				13012-ZH7-004	E14	47	1	14781-ZE1-000	F4	53	16	16100-ZH7-822	G10	75	11
06111-ZK7-U30	L2	147	1	13013-Z4F-004	E15	48	1	14791-ZE0-010	F4	53	17	16100-ZH7-831	G10	75	11
06111-ZK7-V00	L2	147	1	13013-ZH7-003	E14	47	1	15000				16100-ZH7-841	G10	75	11
06164-ZE1-000	G5	70	1	13013-ZH7-004	E14	47	1	15422-767-000	K13	142	1	16100-ZH7-T01	G10	75	11
	G8	73	1	13101-ZF0-020	E15	48	2	15428-767-000	K13	142	2	16100-ZH7-V21	G10	75	11
061A1-ZH7-010	L2	147	1	13101-ZF0-902	E15	48	2	15500-ZK7-V00	E7	40	4	16100-ZH7-W51	G11	76	11
061A1-ZH7-700	L2	147	1	13101-ZH7-010	E16	49	2	15510-ZE1-033	E5	38	2	16100-ZH7-W61	G11	76	11
061A1-ZH7-710	L2	147	1	13101-ZH7-020	E16	49	2	15510-ZE1-043	E5	38	2	16100-ZH7-W71	G6	71	11
061A1-ZH7-720	L2	147	1	13102-ZH7-010	E16	49	2	15550-ZK8-P90	K14	143	1	16100-ZH7-W81	G6	71	11
				13102-ZH7-020	F1	50	2	15552-ZB9-000	K14	143	2	16100-ZK7-S61	G11	76	11
				13103-ZH7-010	E16	49	2	15552-ZK7-S90	K14	143	2	16100-ZK7-S91	G11	76	11
				13103-ZH7-020	F1	50	2	15600-ZE1-003	E8	41	5	16100-ZK7-S92	G11	76	11
11000				13104-ZH7-010	E16	49	2	16100-ZK7-U11	G10	75	11	16551-ZE1-000	E5	38	8
11300-ZE0-010	E7	40	1	13104-ZH7-020	F1	50	2	16100-ZK7-U31	G6	71	11	16551-ZE1-000	E5	38	8
11300-ZE0-613	E7	40	2	13111-ZE0-000	F1	50	3	16100-ZK7-U51	G11	76	11	16550-ZH7-V30	J2	115	6
11300-ZE0-634	E7	40	1	13200-ZE0-000	F1	50	4	16100-ZK7-V01	G6	71	11	16550-ZK7-S50	J12	125	3
11300-ZE0-641	E7	40	1	132A0-ZE0-000	F1	50	4	16106-KW7-900	H2	83	1	16550-ZK7-V00	J2	115	7
11300-ZK7-V00	E7	40	2	13310-YB3-010	E10	43	1	15600-ZG4-003	E8	41	7	16551-ZE0-010	J3	116	8
11300-ZK7-V20	E7	40	2	13310-ZB0-000	E10	43	2	15600-ZE1-003	E8	41	5	J10	123	1	
11300-ZK7-W20	E7	40	2	13310-ZE0-000	E10	43	3	15625-ZE1-003	E8	41	9	J11	124	1	
11347-371-300	G1	66	1	13310-ZE0-601	E10	43	4	15721-883-030	E2	35	8	16552-896-650	J3	116	9
11381-ZH7-800	E7	40	3	13310-ZE0-610	E10	43	5	16166-ZH7-800	G12	77	13	J12	125	4	
11381-ZK7-V00	E7	40	3	13310-ZE0-622	E10	43	6	16166-ZH7-820	G12	77	13	16561-733-010	J11	124	3
11381-ZK7-W20	E7	40	3	13310-ZE0-631	E10	43	7	16166-ZH7-A50	G6	71	13	16561-ZE0-020	J4	117	12
11500-ZE1-611	J13	126	1	13310-ZE0-641	E10	43	8	16166-ZH7-V20	G11	76	13	J10	123	3	
11500-ZK7-V00	J15	128	1	13310-ZE0-650	E10	43	9	16166-ZH7-W50	G6	71	13	16561-ZK7-S50	J12	125	6
11521-ZH8-800	J13	126	2	13310-ZE0-660	E10	43	10	1610-ZB1-015	G5	70	2	16562-ZE1-020	J10	123	4
11521-ZK7-V00	J15	128	2	13310-ZE0-670	E10	43	11	16173-001-004	G8	73	2	16570-733-000	J11	124	5
11521-ZK7-W20	J13	126	2	13310-ZK7-600	E10	43	13	1610-ZE0-025	G5	70	2	16570-ZB0-000	J10	123	5
12000				13310-ZK7-670	E10	43	11	1610-ZE1-812	G8	73	2	16570-ZE0-902	J2	115	3
12000-ZF0-425	E5	38	1	13310-ZK7-880	E10	43	3	1610-ZH7-A20	G8	73	2	16570-ZE0-S10	J2	115	3
12000-ZH7-425	E5	38	1	13310-ZK7-V00	E10	43	12	16011-ZE0-005	G5	70	3	16570-ZH7-U20	J2	115	3
12000-ZK7-405	E5	38	1	13331-357-000	I12	109	1	16013-ZE0-005	G8	73	3	16570-ZK7-S50	J12	125	8
12204-ZE1-306	E1	34	1	14000				16015-ZE0-831	G5	70	5	16570-ZE1-000	J4	117	14
12205-ZE1-315	E1	34	2	14100-ZE0-812	F2	51	2	16015-ZE1-811	G9	74	5	16570-ZH7-W40	J2	115	3
12209-ZH8-003	F2	51	1	14100-ZF0-000	F2	51	2	16015-ZE1-811	G5	70	5	16570-ZH7-W40	J2	115	3
12210-ZH7-405	E1	34	3	14100-ZH7-B20	F2	51	2	16015-ZH7-A21	H1	82	40	16212-ZH7-800	G6	71	15
12210-ZH7-415	E1	34	3	14100-ZK7-800	F2	51	3	16015-ZH7-A21	H1	82	40	16220-ZE1-004	G12	77	17
12216-ZE5-300	E2	35	4	14100-ZK7-870	F2	51	2	16015-ZK7-S91	H1	82	37	16220-ZE1-020	G6	71	16
12251-ZF0-000	E2	35	5	14410-ZE0-010	F2	51	4	16016-ZE0-005	G5	70	6	16221-ZH8-800	G13	78	17
12251-ZH7-800	E2	35	5	14411-ZE0-611	J13	126	3	16016-ZE0-005	G5	70	6	16221-ZH8-801	G6	71	17
12310-ZE1-000	E2	35	6	14411-ZH7-V91	J13	126	3	16016-ZH7-W01	G5	70	7	16571-ZE0-S10	J4	117	14
12310-ZE1-010	E2	35	6	14411-ZK7-V01	J15	128	3	16024-ZE1-811	G5	70	8	16571-ZH7-000	J4	117	14
12310-ZE1-020	E2	35	6	14431-ZE1-000	F2	51	5	16028-ZE0-005	G5	70	9	16571-ZH7-860	J4	117	14
12310-ZE1-842	E2	35	6	14441-ZE1-010	F2	51	6	16028-ZK7-S91	G10	75	9	16571-ZH7-U41	J4	117	14
12391-ZE1-000	E2	35	7	14451-ZE1-003	F2	51	7	16044-ZE0-005	G6	71	10	16571-ZK7-S90	J4	117	14
13000				14451-ZE1-013	F2	51	7	16080-898-631	K15	144	1	16574-ZE1-000	J4	117	15
13010-Z4F-004	E15	48	1	14560-ZK7-800	F2	51	8	16081-471-831	K15	144	2	J12	125	9	
13010-ZH7-003	E12	45	1	14568-ZE1-000	F3	52	9	16100-ZH7-801	G10	75	11	16575-ZH8-000	J4	117	16
13010-ZH7-004	E12	45	1	14568-ZG9-800	F3	52	10	16100-ZH7-812	G6	71	11	16576-891-000	J5	118	17
13011-Z4F-004	E15	48	1	14711-ZF0-000	F3	52	11	16100-ZH7-820	G10	75	11	J12	125	11	
13011-ZH7-003	E13	46	1	14711-ZF0-010	F3	52	11	16044-ZE0-005	G6	71	10	16578-ZE1-000	J5	118	18
13011-ZH7-004	E13	46	1	14721-ZF0-000	F3	52	12	16044-ZE0-005	G6	71	10	J12	125	12	
13012-Z4F-004	E15	48	1	14721-ZH7-810	F4	53	12	16080-898-631	K15	144	1	16580-ZH7-000	J5	118	19
13012-ZH7-003	E14	47	1	14751-ZF1-000	F4	53	13	16081-471-831	K15	144	2	16580-ZH7-810	J6	119	20
				14771-ZE1-000	F4	53	14	16100-ZH7-801	G10	75	11	16580-ZH7-850	J12	125	13
				14773-ZE1-000	F4	53	15	16100-ZH7-812	G6	71	11	16580-ZH7-860	J2	115	2
								16100-ZH7-820	G10	75	11	16580-ZH7-U42	J2	115	4
								16100-ZH7-821	G10	75	11	16580-ZH7-R00	J5	118	20
												16580-ZH7-U40	J5	118	20
												16582-883-300	G6	71	18
												16584-883-300	G13	78	19
													J6	119	21

3

PART NO. INDEX

M 2

Part Number	Address	Page	Ref.	Part Number	Address	Page	Ref.	Part Number	Address	Page	Ref.	Part Number	Address	Page	Ref.	Part Number	Address	Page	Ref.
16584-883-300	J10	123	6	17210-ZE0-822	H2	83	3	17470-ZE1-842	H8	89	11	18310-ZH7-V90	H12	93	4	19610-ZE0-000ZQ	G1	66	2
	J11	124	6	17210-ZE1-822	H2	83	3	17475-ZE1-841	H8	89	12	18310-ZH8-810	H12	93	4	19610-ZE0-000ZR	G1	66	2
	J12	125	14		H8	89	2	17476-ZE1-841	H8	89	13	18310-ZH8-T30	H12	93	4	19610-ZE0-000ZS	G1	66	2
16592-ZE1-810	J6	119	22		K14	143	11	17478-ZE1-841	H8	89	14	18310-ZK7-V01	I2	99	1	19610-ZH7-V90ZB	G1	66	2
	J11	124	7	17210-ZK7-V01	H10	91	3	17478-ZE1-850	H9	90	15	18310-ZK8-V50	H12	93	4	19610-ZK7-V00ZB	G1	66	2
	J12	125	15	17211-ZB2-000	H11	92	2	17500-ZE1-813ZA	I5	102	9	18315-ZE1-000	H16	97	3	19610-ZK7-V00ZC	G1	66	2
16594-883-010	J6	119	23	17211-ZE1-000	H5	86	1	17505-ZB2-003	I9	106	8	18320-ZB2-000	I3	100	2	19610-ZK7-V00ZD	G1	66	2
	J12	125	16	17212-ZB2-000	H11	92	3		K15	144	5	18320-ZE1-T02	H12	93	5	19611-ZH7-810	G2	67	3
16598-ZE1-000	G6	71	19	17212-ZE1-000	H5	86	2	17505-ZE1-013	I5	102	10	18320-ZF1-H01	H13	94	5	19611-ZH7-820	G2	67	4
	G13	78	20	17216-PM4-300	H10	91	4	17505-ZH7-A21	I5	102	10	18320-ZF1-H51	H16	97	4	19612-ZH7-000	G2	67	3
16599-ZG1-M10	J6	119	24	17217-PM4-300	H10	91	5	17506-ZK7-800	I10	107	2	18320-ZH8-W01	H13	94	5	19612-ZH7-821	G2	67	4
	J10	123	7	17218-ZE0-821	H2	83	4	17507-ZK7-800	I10	107	3	18325-ZB2-000	I3	100	3	19612-ZK7-V00	G2	67	3
16610-ZB2-000	G13	78	21	17218-ZE1-821	H2	83	4	17510-ZB4-000ZH	I9	106	9	18325-ZE1-010	H13	94	6	19613-ZE1-020	G2	67	5
16610-ZE1-000	G6	71	20		H8	89	3	17510-ZE0-020ZA	I5	102	11	18329-ZB2-000	I3	100	4	19630-ZH7-000	G2	67	6
	G14	79	21		K14	143	12	17510-ZE0-020ZB	I5	102	11	18330-ZB2-000	I3	100	5				
16610-ZE1-810	G6	71	21	17218-ZK7-V01	H10	91	6	17510-ZE0-020ZG	I6	103	11	18331-883-810	H16	97	5	20000			
	G14	79	22	17219-733-010	H8	89	4	17510-ZE0-020ZK	I6	103	11	18338-ZB3-E30	I3	100	6	20001-VD6-R00	K9	138	1
16615-ZE1-010	G6	71	22	17220-ZB2-000	H11	92	4	17510-ZE0-020ZL	I6	103	11	18338-ZK7-V01	I2	99	2				
	G14	79	23	17230-ZE0-820	H3	84	5	17510-ZH7-A20ZD	I6	103	11	18338-ZK7-V20	I2	99	3				
16617-890-010	G6	71	23	17230-ZE1-820	H3	84	5	17510-ZK7-800	I10	107	4	18340-ZE0-A60	H13	94	7	21000			
	G14	79	24	17230-ZE1-841	H8	89	5	17510-ZK7-U20ZA	I6	103	11	18340-ZE1-010	H13	94	8				
16617-ZJ1-840	J9	122	39	17230-ZE1-850	H8	89	6	17510-ZK7-U20ZB	I6	103	11		K14	143	3	21210-VD6-854	K9	138	2
16727-705-000	J6	119	25	17230-ZK7-V01	H10	91	7	17510-ZK7-U20ZC	I11	108	3	18340-ZH7-U20	H15	96	28	21215-VD6-851	K9	138	3
16729-705-010	J6	119	26	17231-ZB2-000	H11	92	5	17512-ZK7-S90	I7	104	25		K14	143	19	21225-VD6-853	K9	138	4
16854-ZH8-000	G6	71	24	17231-ZE0-000	H5	86	3	17512-ZK7-S91	I7	104	25	18355-898-630	I3	100	7	21510-883-621	J16	129	1
	I4	101	3	17232-891-000	H3	84	6	17561-ZK7-800	I10	107	5	18355-ZE1-000	H13	94	9	21521-883-741	K2	131	1
					H8	89	7	17620-899-013	I9	106	10	18355-ZE1-810	H16	97	6	21591-ZH8-620	J16	129	2
	I9	106	2		K14	143	13	17620-Z0T-305	I8	105	34		K14	143	14	21591-ZH8-740	K2	131	2
	I10	107	1	17233-896-701	H12	93	1		I11	108	4	18381-ZE1-800	I3	100	8	21610-822-611	J16	129	3
	I11	108	1		H16	97	1		K15	144	6	18381-ZH8-800	H14	95	10	21621-883-741	K2	131	3
16854-ZH8-810	I4	101	4	17235-ZE1-831	H3	84	7	17620-ZE2-W00	I8	105	32		H16	97	7	21691-ZH8-800	J16	129	4
	I8	105	30	17238-ZE0-010	H3	84	8	17620-ZE7-000	I10	107	6		I2	99	4	21692-ZH8-800	K2	131	4
16910-GB2-005	I4	101	5		H5	86	4	17620-ZH7-023	I6	103	12		I3	100	9				
	K16	145	1		H7	88	2	17622-888-010	I10	107	7		K14	143	15	22000			
16910-ZG0-U02	I4	101	6		H8	89	8	17624-ZE7-000	I10	107	8	18431-ZH8-W50	H14	95	11				
16950-898-633	K15	144	3	17238-ZE7-010	H4	85	8	17631-329-003	I8	105	33		H16	97	8	22121-887-620	J16	129	5
16950-ZB4-015	I9	106	3		H10	91	8	17631-899-000	I9	106	11	18433-ZH8-W40	H14	95	12	22201-822-610	J16	129	6
16952-GG2-731	K15	144	4	17239-733-000	H8	89	9	17631-Z0T-812	I8	105	35		H16	97	9	22311-822-610	J16	129	7
16952-ZB4-005	I9	106	4	17239-ZB2-000	H11	92	6		I11	108	5	18434-ZH8-W40	H14	95	13	22350-822-610	J16	129	8
16952-ZE6-000	K14	143	17	17239-ZE1-000	H4	85	9		K15	144	7		H16	97	10	22411-822-611	J16	129	9
16953-ZE1-812	G6	71	25		H5	86	5	17631-ZH7-003	I6	103	13	18436-ZH8-W40	H14	95	14	22421-822-610	J16	129	10
	G14	79	25		H7	88	3	17670-899-000	I9	106	12		H16	97	11	22423-767-000	K9	138	5
16954-ZE1-812	G6	71	26		H10	91	9	17670-ZH7-A81	I6	103	14	18466-ZH8-W40	H14	95	15	22521-822-610	J16	129	11
	G14	79	26	17251-ZE0-S10	H10	91	10	17672-880-000	I6	103	15		H16	97	12	22531-887-620	J16	129	12
16955-ZE1-000	I5	102	7	17252-ZB2-000	H11	92	7	17672-887-791	I6	103	15	18522-ZE1-000	H14	95	16	22535-822-610	J16	129	13
	I11	108	2	17255-758-000	H10	91	11	17672-ZE2-W01	I6	103	14		K14	143	4				
16956-ZE1-811	G6	71	27	17401-ZE1-810	H7	88	4		I11	108	6					23000			
	G14	79	27	17402-ZE1-810	H7	88	5		K15	144	8					19000			
16957-ZE1-812	G6	71	28	17403-ZE1-810	H7	88	6	17672-ZK7-800	I10	107	9					23110-ZE0-610	J13	126	4
	G14	79	28	17404-841-000	H7	88	7	17673-893-000	I6	103	16	19511-ZE0-000	I12	109	2	23110-ZH7-V90	J13	126	4
16958-397-771	I9	106	5	17410-ZE0-030	H4	85	10					19511-ZE1-000	I12	109	2	23120-883-620	J16	129	14
16959-471-831	I9	106	6		H5	86	6					19512-ZA8-000	K16	145	2	23121-ZK7-V00	J15	128	4
16967-GA6-671	I9	106	7	17410-ZE0-811	H5	86	6					19610-ZB0-601ZD	G1	66	2	23151-ZK7-V00	J15	128	5
16967-ZE0-811	G15	80	29		H7	88	8	18300-ZH8-840	H12	93	2	19610-ZE0-000ZE	G1	66	2	23161-822-611	J16	129	15
				17410-ZE0-840	H8	89	10	18310-ZB3-C00	I3	100	1	19610-ZE0-000ZF	G1	66	2	23236-VD6-871	K9	138	6
17000				17410-ZE1-020	H4	85	10	18310-ZE0-A20	H12	93	3	19610-ZE0-000ZG	G1	66	2	23384-767-000	K9	138	7
				17410-ZE1-P30	H10	91	12	18310-ZE1-821	H16	97	2	19610-ZE0-000ZH	G1	66	2	23710-883-740	K2	131	5
17200-ZK7-V01	H10	91	2	17421-ZE1-000	H6	87	7	18310-ZE1-900	H12	93	4	19610-ZE0-000ZK	G1	66	2	23710-ZE0-613	J13	126	5
17205-PC6-000	I5	102	8		H7	88	9	18310-ZF1-000	H12	93	4	19610-ZE0-000ZP	G1	66	2	23710-ZE0-903	J14	127	14

3

PART NO. INDEX

M 3

Part Number	Address	Page	Ref.	Part Number	Address	Page	Ref.	Part Number	Address	Page	Ref.	Part Number	Address	Page	Ref.	Part Number	Address	Page	Ref.
23711-822-610	J16	129	16	F12	61	2		30700-ZF5-013	I16	113	2	50000				87524-883-690	K4	133	11
24000				28410-ZH8-003ZJ	F6	55	2	30700-ZJ1-841	J1	114	14					87526-ZH8-000	K4	133	12
				F12	61	2						50319-ZB2-000	I9	106	13	87528-733-E90	K4	133	13
24176-VD6-852	K9	138	8	28410-ZH8-003ZK	F6	55	2	31000				K15	144	9	87528-733-E91	K5	134	13	
				F12	61	2									L1	146	4		
25000				28410-ZH8-003ZV	F6	55	2	31100-ZE0-010	I12	109	5	56000				87528-777-000	K4	133	13
				F12	61	2		31100-ZE0-020	I13	110	5					87528-ZB2-630	K4	133	13
25010-VD6-851	K9	138	9	28410-ZH8-003ZW	F6	55	2	31100-ZE0-811	I13	110	6	56850-767-000	K13	142	3	87528-ZE0-900	K3	132	1
25011-VD6-851	K9	138	10	F12	61	2		31100-ZE0-812	I13	110	6	56862-767-300	K13	142	4	87528-ZE1-690	K4	133	13
25012-VD6-850	K9	138	11	28420-ZE1-003	F10	59	3	31107-ZC0-003	K16	145	4					87528-ZE1-810	K4	133	13
25013-VD6-850	K9	138	12	28420-ZH8-013	F6	55	3	31109-ZC0-003	K16	145	5	60000				L1	146	3	
25014-VD6-850	K9	138	13	28421-ZH8-801	F12	61	3	31112-ZC0-003	K16	145	6					87528-ZH7-000	K5	134	13
2510-VD6-M50	K9	138	14	28422-ZE1-003	F10	59	4	31510-ZE1-003	I16	113	4	60407-812-000	K16	145	8	L1	146	4	
25310-VD6-851	K9	138	15	28422-ZH8-013	F6	55	4	31510-ZE1-711	I16	113	5					87528-ZH8-S00	K4	133	13
25312-VD6-851	K9	138	16	28422-ZH8-801	F12	61	4	31510-ZE1-811	I16	113	6	68000				87530-ZH7-010	K5	134	14
25321-VD6-852	K9	138	16	28423-ZE1-003	F10	59	5	31510-ZE1-821	I16	113	4					87530-ZH7-821	K5	134	14
25342-773-003	K9	138	17	28431-ZE1-003	F10	59	6	31510-ZE1-831	I16	113	6	68325-899-000	I9	106	14	87532-ZB4-H50	K5	134	15
25343-773-000	K9	138	18	28431-ZH8-801	F13	62	5	31510-ZK7-S91	J1	114	15	68326-ZB2-000	E6	39	9	87532-ZH7-000	K5	134	16
25411-VD6-852	K9	138	19	28433-ZH8-003	F6	55	5	31510-ZK7-U50	I16	113	5	68327-ZB2-000	E6	39	10	87532-ZH8-000	K5	134	17
25415-VD6-851	K9	138	20	28433-ZH8-801	F13	62	6	31511-ZE1-000	I16	113	7	68328-ZB2-000	E6	39	11	87532-ZH8-810	K6	135	17
25416-VD6-853	K9	138	21	28441-ZE1-003	F10	59	7	31512-ZE1-000	I16	113	8								
25420-VD6-852	K9	138	22	28441-ZH8-003	F7	56	6	31610-ZH7-003	I16	113	4	78000							
25421-VD6-852	K9	138	23	28441-ZH8-801	F14	63	7									87532-ZH8-W40	K5	134	16
25422-VD6-851	K9	138	24	28442-ZE1-003	F10	59	8	32000				78118-YB0-003	K14	143	5	L1	146	5	
25425-VD6-852	K9	138	25	28442-ZH8-003	F7	56	7									87532-ZK7-800	K6	135	17
25431-VD6-851	K10	139	26	F14	63	8		32105-ZE1-000	I16	113	9	81000				87533-ZC0-630	K6	135	20
25437-VD6-852	K10	139	27	28443-ZE1-003	F10	59	9	32197-ZH8-003	G2	67	7					87534-ZE1-000	K6	135	21
25510-VD6-854	K10	139	28	28443-ZH8-003	F8	57	8	32302-734-K50	E8	41	10	81329-567-020	G3	68	12	87534-ZE1-841	K6	135	22
25518-VD6-850	K10	139	29	28443-ZH8-801	F14	63	9	32303-ZE0-850	G2	67	8					87535-ZE1-841	K6	135	23
25521-VD6-850	K10	139	30	28445-ZE1-003	F10	59	10					83000				87539-737-J00	K6	135	24
25525-773-000	K10	139	31	28446-ZE1-003	F10	59	11	34000								87539-898-620	K6	135	25
25526-VD6-851	K10	139	32	28447-ZE1-003	F10	59	12					83501-ZF1-000	K7	136	1	87565-ZB4-A00	I9	106	15
25813-773-000	K10	139	33	28448-ZE1-003	F10	59	13	34100-735-J10	K16	145	7					K6	135	26	
28000				28450-ZH7-801	I13	110	8	34150-ZH7-003	G2	67	9	87000				87565-ZE2-000	K6	135	27
				28450-ZH7-811	I12	109	3	34150-ZH7-013	G2	67	9					87565-ZE2-A01	K6	135	27
				28451-ZE0-003	I12	109	4					87101-733-000	K3	132	1	87593-737-J00	K6	135	28
28400-ZE1-003ZF	F10	59	1	28451-ZH7-003	I14	111	10	35000				87106-737-J00	K3	132	3	87594-ZH7-B20	K6	135	29
28400-ZH8-013YA	F5	54	1	28451-ZH7-801	I13	110	9					87106-ZH8-S00	K3	132	2				
28400-ZH8-013ZB	F5	54	1	28461-ZE1-003	F10	59	14	35120-Z0D-V81	G2	67	10	87114-ZH7-000	K6	135	31	89000			
28400-ZH8-013ZG	F5	54	1	28461-ZH8-003	F8	57	9	35210-MA6-000	E8	41	11	87135-ZE2-020	K3	132	4				
28400-ZH8-013ZJ	F5	54	1	F14	63	10		35376-ZV5-830	I4	101	4					89000-ZE1-000	K7	136	2
28400-ZH8-013ZK	F5	54	1	28462-ZE1-003	F10	59	15					87152-ZH7-C31	K3	132	6	89000-ZH7-T00	K8	137	14
28400-ZH8-013ZV	F5	54	1	28462-ZH8-003	F8	57	10					87516-ZM7-801	K6	135	32	89001-ZF1-000	K7	136	3
28400-ZH8-013ZV	F5	54	1	F15	64	11		36000				L1	146	6		89102-538-000	K7	136	4
28400-ZH8-023YA	F11	60	1	28462-ZH8-R10	F8	57	10					87520-ZH8-000	K4	133	7	89103-538-000	K7	136	5
28400-ZH8-023ZB	F11	60	1	F14	63	11		36100-ZE1-015	G2	67	10	87521-ZH7-020	K4	133	8	89210-ZF1-000	K7	136	6
28400-ZH8-023ZG	F11	60	1	28470-816-000	F8	57	10	36100-ZF6-P81	G4	69	17	87521-ZH7-030	K4	133	8	89216-ZF1-000	K7	136	7
28400-ZH8-023ZJ	F11	60	1					36100-ZH7-003	G2	67	10	87521-ZH7-040	K4	133	8	89216-ZH8-S00	K7	136	7
28400-ZH8-023ZK	F11	60	1	30000				36100-ZH7-W41	G4	69	17	87521-ZH7-832	K4	133	8	89218-ZE1-000	K7	136	8
28400-ZH8-023ZV	F11	60	1					36100-ZH8-W41	G2	67	10	87521-ZH7-Y11	K4	133	8	89219-805-000	K7	136	9
28400-ZH8-023ZW	F11	60	1	30401-GA7-000	K16	145	3	36101-ZE1-010	G3	68	11	87522-ZB3-K01	K4	133	9				
28400-ZH8-R10ZD	F5	54	1	30500-ZE1-033	I15	112	1	36101-ZK7-S90	G3	68	11	87522-ZE1-810	K3	132	2	90000			
28400-ZH8-R11ZA	F11	60	1	30500-ZE1-043	I15	112	1	36101-ZK7-U50	G3	68	11	87522-ZH8-W41	K4	133	10				
28410-ZE1-003ZF	F10	59	2	30500-ZE1-053	I15	112	1					L1	146	1	90001-ZE1-000	F1	50	5	
28410-ZH8-003YA	F6	55	2	30500-ZE1-063	I16	113	1	40000				87522-ZH9-010	K3	132	1	90001-ZK7-V00	K14	143	6
	F12	61	2	30500-ZE1-073	I16	113	1					L1	146	2	90002-883-740	K2	131	6	
28410-ZH8-003ZB	F6	55	2	30600-ZE1-013	I16	113	2	40311-767-000	K10	139	34	87522-ZH9-820	K3	132	1	90002-ZG0-003	H14	95	17
	F12	61	2	30700-ZE1-013	I16	113	2					87522-ZH9-821	K3	132	1	H16	97	13	
28410-ZH8-003ZG	F6	55	2	30700-ZE8-003	I16	113	3					87522-ZK7-800	K3	132	1	K14	143	7	

PART NO. INDEX



Part Number	Address	Page	Ref.	Part Number	Address	Page	Ref.	Part Number	Address	Page	Ref.	Part Number	Address	Page	Ref.	Part Number	Address	Page	Ref.
90002-ZK7-V00	K14	143	6	90115-459-770	H11	92	8	90851-898-000	I9	106	16		G15	80	31	94251-04000	K11	140	58
90003-ZE1-000	E10	43	16	90121-952-000	J1	114	13	90852-898-000	K15	144	10		G16	81	31	94251-08000	E6	39	21
90003-ZH8-003	F8	57	11	90121-ZE0-000	J7	120	30	90854-ZB3-000	I6	103	18	93500-03008-1G	G15	80	31	94301-08100	K1	130	28
90003-ZH8-801	F15	64	12		J8	121	33		K15	144	11	93500-04006-OH	J8	121	35		K11	140	59
90003-ZK7-W20	J13	126	6	90131-883-000	K2	131	7						J12	125	22	94301-08140	E9	42	18
90004-ZH7-003	I6	103	17	90131-ZE1-000	E6	39	12	91000				93500-04008-0A	G6	71	31		J14	127	12
	I11	108	7	90136-MT4-000	H15	96	24						G16	81	32	94301-10120	K11	140	60
90008-ZE2-003	F9	58	12	90201-415-000	H6	87	8	91001-878-003	E6	39	16	93500-04020-0A	H10	91	15	94301-10160	E2	35	12
	F10	59	16	90201-878-003	I13	110	7		E8	41	15	93500-05008-0A	G6	71	32	94302-05080	K11	140	61
	F16	65	13	90203-ZA0-800	H6	87	9	91007-MN5-003	K10	139	45		G16	81	33	94303-08140	E9	42	18
90012-ZE0-010	F4	53	18	90206-ZE1-000	F4	53	19	91069-VD6-851	K11	140	46	93500-05016-0A	J9	122	36		J15	128	11
90013-883-000	E2	35	9	90300-GB0-900	H9	90	16	91151-VD6-851	K11	140	47		J12	125	23	94305-20122	G7	72	33
	G3	68	13	90301-473-003	H9	90	17	91201-Z0T-801	J13	126	10	93500-05025-OH	J8	121	30		G16	81	34
	J7	120	27	90302-KF9-900	H15	96	25		K2	131	8		J9	122	37	94305-40282	K11	140	62
	J10	123	8		I1	98	19	91202-722-003	K11	140	48		J12	125	24	94520-30000	K11	140	63
	J11	124	8	90325-044-000	H4	85	11	91202-805-610	J16	129	22	93500-05028-0A	J11	124	10				
	J12	125	17		H6	87	10	91202-Z2F-801	J16	129	22	93500-05030-0A	J8	121	30	95000			
90014-952-000	E8	41	12		H7	88	10	91202-ZE6-013	E6	39	17	93500-05035-0A	J10	123	12				
90015-883-000	E8	41	13		H9	90	18	91203-ZE0-013	E9	42	16	93600-05010-0A	I6	103	21	95001-45035-40	I6	103	23
	I16	113	10	90403-887-620	J16	129	19	91231-891-003	E6	39	23		I9	106	18	95001-45075-60	I7	104	23
	J13	126	6	90417-115-000	K10	139	36	91252-888-003	J15	128	9		K15	144	13				
90015-ZE5-010	J7	120	28	90451-ZE1-000	E6	39	13	91255-VD6-851	K11	140	49	93891-06020-07	H15	96	26	95001-45110-40	I7	104	24
	J10	123	10	90454-428-000	J15	128	6	91272-733-931	K11	140	50		I1	98	20	95001-45140-40	G7	72	34
	J11	124	9	90456-ZE1-000	J13	126	7	91301-805-000	J16	129	23	93893-04012-07	H9	90	19		I7	104	25
	J12	125	18		J15	128	7	91304-GB1-900	K11	140	51						I10	107	12
90016-ZE1-000	H14	95	18	90471-ZE1-610	J13	126	8	91304-MJ0-003	E9	42	17	94000				95001-45250-40	K15	144	14
	H16	97	14		E15	128	8	91352-VD6-851	K11	140	52					95001-45300-40	I9	106	19
90016-ZE7-W00	J7	120	29	90473-842-000	J10	43	17	91353-671-004	E6	39	18	94001-06000-0S	H4	85	12	95001-45350-60	I7	104	23
90016-ZG9-N30	J7	120	29	90474-704-000	K10	139	37		I6	103	19	94001-08000-0S	H15	96	24				
				90503-VD6-850	K10	139	38		I11	108	8		I1	98	21				
	J10	123	11	90504-VD6-851	K10	139	39	91355-VD6-852	K11	140	53		I2	99	5	95001-45400-60	G7	72	34
90018-ZE1-000	I16	113	11	90508-VD6-850	K10	139	40	91360-VD6-851	K11	140	54		I3	100	11	95001-45750-40	I7	104	25
90019-883-000	J1	114	12	90509-750-000	I10	107	10	91361-VD6-901	K11	140	55		K14	143	16	95002-02070	E9	42	19
90022-888-010	G3	68	14	90551-ZE0-000	F1	50	6	91406-657-671	G3	68	15	94050-06000	H4	85	13	95002-02080	I8	105	26
	J8	121	31	90565-VD6-852	K10	139	41	91424-Z4F-801	I7	104	25		H6	87	12		I9	106	20
	J12	125	19	90566-VD6-852	K10	139	41	91462-SA5-950	K13	142	5		H7	88	11		I10	107	13
90029-888-000	E8	41	14	90567-VD6-852	K10	139	41	91473-PA1-003	H10	91	14		H9	90	20		I11	108	11
90031-ZA1-003	K16	145	9	90568-VD6-852	K10	139	41		I6	103	20		H10	91	16		K15	144	15
90031-ZC0-003	K16	145	10	90569-VD6-851	K10	139	41	91502-ZG9-800	F4	53	21		I2	99	6	95002-02100	I8	105	27
90043-ZB2-003	E2	35	10	90570-VD6-852	K10	139	41	91551-898-000	I9	106	17		I3	100	12	95002-40800-08	G7	72	35
90043-ZE1-010	E2	35	10	90601-ZE1-000	E6	39	14	91552-898-000	K15	144	12		I6	103	22		I8	105	28
90043-ZE1-020	E2	35	10		K14	143	18	91589-VD6-851	K11	140	56		I10	107	11				
90047-ZE1-000	E2	35	11	90601-ZH7-013	G4	69	18		I11	108	9		I11	108	9	95002-40850-08	K16	145	11
90050-ZE1-000	H14	95	19	90602-ZE1-000	E6	39	15	92000	J9	122	38		J9	122	38	95002-41200-08	K14	143	10
				90605-230-000	G6	71	29		J10	123	13		J10	123	13	95002-50000	I8	105	29
	H16	97	15		G15	80	30	92000-08025-0A	E10	43	16		J11	124	11	95002-80000	E3	36	13
					J8	121	34		J14	127	11		J12	125	25	95003-10024-31	H1	82	39
90050-ZE3-H00	H16	97	15		J12	125	21	92101-08020-0A	I3	100	10	94050-06080	H11	92	9	95003-10040-31	H1	82	39
90050-ZH8-W40	H14	95	21	90617-SA0-003	I8	105	31	92101-08025-0A	E10	43	16	94050-10000	E6	39	19	95005-35150-10	E9	42	20
	I1	98	17		K14	143	8		J14	127	11		K14	143	9	95701-06008-00	G4	69	16
90055-ZE1-000	H14	95	22	90663-VD6-850	K10	139	42		J15	128	10	94101-06800	E6	39	20	95701-06010-00	H11	92	10
	H15	96	23	90701-ZG9-800	F4	53	20	92101-08035-0A	J16	129	24		H4	85	14	95701-06012-00	E6	39	22
				90741-883-621	J16	129	20	92301-04006-OH	J9	122	40	94103-05700	H15	96	27		I1	98	23
	H16	97	13	90741-883-810	E11	44	18	92800-12000	J16	129	25		I1	98	22		I3	100	13
	K14	143	20		J13	126	9					94103-08700	I2	99	7	95701-06012-08	K11	140	64
90056-ZL0-000	I1	98	18	90741-889-810	J16	129	21	93000				94109-12000	K1	130	26	95701-06016-00	H10	91	17
90081-MC7-000	K10	139	35	90745-ZE1-600	E11	44	18						K2	131	9		I2	99	8
90114-SA0-000	J8	121	32	90755-VD6-900	K10	139	43	93494-06020-08	H6	87	11	94109-14000	K11	140	57		K11	140	65
	J12	125	20	90759-VD6-850	K10	139	44	93500-03006-1H	G6	71	30	94111-08800	K1	130	27	95701-06016-08	K11	140	66



PART NO. INDEX

M 5

Part Number	Address	Page	Ref.	Part Number	Address	Page	Ref.	Part Number	Address	Page	Ref.	Part Number	Address	Page	Ref.
95701-06020-00	H4	85	15	99000											
	H6	87	11												
	H7	88	12	99001-10120	K7	136	10								
	H9	90	21	99001-10140	K7	136	11								
	H10	91	13	99001-14170	K7	136	12								
95701-06025-00	I2	99	9	99004-21001	K7	136	8								
	I6	103	17	99008-02300	K8	137	13								
	I10	107	14	99101-ZF5-0550	G16	81	35								
95701-06025-08	K11	140	67	99101-ZF5-0580	G16	81	35								
95701-06032-00	I10	107	15	99101-ZF5-0600	G16	81	35								
	K11	140	68	99101-ZH7-0600	G16	81	35								
95701-06055-00	K1	130	29	99101-ZH8-0550	G7	72	36								
95701-08012-00	I2	99	10		G16	81	35								
95701-08018-00	I2	99	11	99101-ZH8-0580	G7	72	36								
95701-08020-00	I2	99	11		G16	81	35								
95701-08022-00	K1	130	30	99101-ZH8-0600	G7	72	36								
95701-08032-08	K2	131	10		G16	81	35								
95701-08035-00	J15	128	12	99101-ZH8-0620	G7	72	36								
	K2	131	11		G16	81	35								
95701-08045-08	K11	140	69	99101-ZH8-0680	H1	82	35								
95701-08055-00	E3	36	14	99101-ZK7-0580	H1	82	35								
	J15	128	13	99101-ZK7-0600	H1	82	35								
95701-08065-00	K11	140	70	99101-ZK7-0620	H1	82	35								
95701-08070-08	K12	141	71	99204-ZE0-0350	G7	72	37								
95701-08090-08	K12	141	72		H1	82	36								
95701-10016-00	K12	141	73	99204-ZE2-0380	H1	82	36								
95723-08055-00	E3	36	14												
95900-06025-00	I6	103	17												
96000															
96100-60010-00	K12	141	74												
96100-60020-00	K12	141	75												
96100-60030-00	K12	141	76												
96100-60050-00	J15	128	14												
96100-62040-00	K2	131	12												
96100-62050-00	J14	127	13												
	K1	130	31												
96100-62060-00	K1	130	32												
96100-63050-00	K2	131	13												
96211-06000	K12	141	77												
96211-08000	K12	141	78												
98000															
98079-54841	E3	36	15												
98079-54846	E3	36	15												
98079-54854	E3	36	15												
98079-54855	E3	36	15												
98079-55841	E3	36	15												
98079-55846	E4	37	15												
98079-55854	E4	37	15												
98079-55855	E4	37	15												
98079-56841	E4	37	15												
98079-56846	E4	37	15												
98079-56854	E4	37	15												
98079-56855	E4	37	15												

3

PART NAME INDEX

Part name	Address	Page	Ref.	Part name	Address	Page	Ref.	Part name	Address	Page	Ref.
[A]				BOLT, FLANGE, 6X10	F16	65	13	BOLT, GOVERNOR ARM	J12	125	18
ALERT UNIT, OIL	G2	67	9	H11	92	10	BOLT, HEX., 5/16"	E10	43	16	
ARM COMP., GOVERNOR	J2	115	6	E2	35	9	BOLT, HEX., 8X20	I3	100	10	
			7	E6	39	22	BOLT, HEX., 8X25	E10	43	16	
			3	G3	68	13		J14	127	11	
ARM COMP., NEUTRAL VALVE	J12	125	3	I1	98	23		J15	128	10	
ARM, CLUTCH	K9	138	8	I3	100	13	BOLT, HEX., 8X35	J16	129	24	
ARM, GOVERNOR	K10	139	34	J7	120	27	BOLT, MUDGUARD	H9	90	16	
	J3	116	8	J10	123	8	BOLT, PIVOT, 8MM	F4	53	18	
	J10	123	1	J11	124	8	BOLT, PLUG, 14MM	K10	139	35	
	J11	124	1	J12	125	17	BOLT, RECESSED, 4X6	J9	122	40	
ARM, VALVE ROCKER	F2	51	5	K11	140	64	BOLT, STUD, 10X32	K14	143	6	
ARRESTER, SPARK	H13	94	9	H14	95	18	BOLT, STUD, 10X60	K14	143	6	
	H16	97	6	H16	97	14	BOLT, STUD, 6X109	E2	35	10	
	I3	100	7	BOLT, FLANGE, 6X14	E8	41	BOLT, STUD, 6X112	E2	35	10	
	K14	143	14	BOLT, FLANGE, 6X16	E8	41	BOLT, STUD, 6X94	E2	35	10	
				H10	91	17	BOLT, STUD, 8X32	E2	35	11	
				I2	99	8	BOLT, WINKER SETTING	H11	92	8	
[B]				K11	140	65	BOWL SET, CONTROL	K9	138	11	
BAG SET, TOOL	K7	136	3			66	BOX, TOOL	K7	136	1	
BAG, TOOL, 230MM	K8	137	13	BOLT, FLANGE, 6X20	G3	68	BUSH, CONTROL BOWL	K10	139	33	
BALL, STEEL,	K12	141	77	H4	85	15					
			78	H6	87	11	[C]				
BAND, AIR CLEANER CONNECTING				H7	88	12	CABLE, DOUBLE CONNECTOR	I16	113	9	
				H9	90	21	CAMSHAFT ASSY.	F2	51	2	
BARREL ASSY., CYLINDER	H10	91	11	H10	91	13					
BASE COMP., CONTROL	E5	38	1	J8	121	31	CAP ASSY., FUEL TANK	I10	107	6	
	J5	118	19	J12	125	19	CAP ASSY., NOISE SUPPRESSOR	I16	113	2	
			20	I16	113	11					
	J6	119	20	BOLT, FLANGE, 6X23	I2	99					
	J12	125	13	BOLT, FLANGE, 6X25	I6	103					
BASE COMP., MUFFLER COVER	H14	95	14	I10	107	14					
	H16	97	11	J1	114	13	CAP ASSY., OIL FILLER	E8	41	5	
BEARING SET, THRUST NEEDLE ...	K9	138	13	K11	140	67					
BEARING, RADIAL BALL, 6001 ...	K12	141	74	E8	41	13					
BEARING, RADIAL BALL, 6002 ...	K12	141	75	I16	113	10					
BEARING, RADIAL BALL, 6003 ...	K12	141	76	J13	126	6	CAP COMP., FUEL FILLER	K1	130	33	
BEARING, RADIAL BALL, 6005 ...	J15	128	14	BOLT, FLANGE, 6X29	I6	103		I6	103	12	
BEARING, RADIAL BALL, 6204 ...	K2	131	12	I11	108	7		I8	105	32	
BEARING, RADIAL BALL, 6205 ...	J14	127	13	I10	107	15					
	K1	130	31	K11	140	68					
BEARING, RADIAL BALL, 6206 ...	K1	130	32	BOLT, FLANGE, 6X55	K1	130					
BEARING, RADIAL BALL, 62/22 ..	E6	39	16	BOLT, FLANGE, 6X8	G4	69					
	E8	41	15	BOLT, FLANGE, 8X12	I2	99	CAP, CLEANER	H6	87	7	
BEARING, RADIAL BALL, 6305 ...	K2	131	13	BOLT, FLANGE, 8X18	I2	99		H7	88	9	
BEARING, RADIAL BALL, 6904 ...	K10	139	45	BOLT, FLANGE, 8X20	I2	99	CAP, MUFFLER	H16	97	5	
BEARING, THRUST BALL, 51204 ..	K11	140	46	BOLT, FLANGE, 8X22	K1	130	CAP, PRE AIR CLEANER	H8	89	12	
BODY, CLEANER	H7	88	4	BOLT, FLANGE, 8X32	K2	131	CARBURETOR ASSY.	G6	71	11	
BODY, OIL CAP	K13	142	4	BOLT, FLANGE, 8X35	J15	128		G10	75	11	
BOLT-WASHER, 6X20	H6	87	11			12		G11	76	11	
BOLT, BREATHING	K2	131	6	BOLT, FLANGE, 8X45	K11	140	CASE COMP., AIR CLEANER	H11	92	4	
BOLT, CHECK VALVE	K10	139	31	BOLT, FLANGE, 8X55	E3	36	CASE COMP., PUMP	K9	138	14	
BOLT, CONNECTING ROD	F1	50	5			13	CASE COMP., RECOIL STARTER	F6	55	2	
BOLT, DRAIN PLUG	E6	39	12	J15	128	13		F10	59	2	
BOLT, DRAIN PLUG, 12MM	J16	129	25	BOLT, FLANGE, 8X65	K11	140		F12	61	2	
BOLT, DRAIN PLUG, 12X15	K2	131	7	BOLT, FLANGE, 8X70	K12	141	CASE COMP., RR. TRANSMISSION ..	K9	138	2	
BOLT, FLANGE, 10X16	K12	141	73	BOLT, FLANGE, 8X90	K12	141	CASE, PRE AIR CLEANER	H8	89	11	
BOLT, FLANGE, 5X10	J1	114	12	BOLT, GOVERNOR ARM	J7	120	CASE, RECOIL STARTER SPRING ...	F10	59	10	
BOLT, FLANGE, 6X10	F9	58	12			10	CASE, REDUCTION	J16	129	1	
	F10	59	16	J10	123	10		K2	131	1	
				J11	124	9					

PART NAME INDEX

Part name	Address	Page	Ref.	Part name	Address	Page	Ref.	Part name	Address	Page	Ref.
CENTER, CLUTCH	J16	129	5	COIL ASSY., LAMP	J1	114	15	CRANKSHAFT COMP.	E10	43	9
CENTER, CLUTCH WEIGHT	J16	129	13	COLLAR B, AIR CLEANER	H4	85	9				10
CHAIN, DRIVE	J16	129	15		H5	86	5				11
CHAIN, P.T.O. DRIVE	J13	126	3		H7	88	3				12
	J15	128	3		H8	89	9				13
CHAMBER SET, FLOAT	G5	70	5		H10	91	9	CUP, FUEL STRAINER	G15	80	29
	G9	74	5	COLLAR, AIR CLEANER	H3	84	8		I9	106	7
	H1	82	37		H4	85	8		K15	144	2
			40		H5	86	4	CUSHION, C.D.I. UNIT	K16	145	3
CHOKE KIT, REMOTE CONTROL	G5	70	1		H7	88	2				
	G8	73	1		H8	89	8	[D]			
CHOKE SET	G6	71	10		H10	91	8				
	G10	75	10	COLLAR, AIR CLEANER CASE	H12	93	1	DEFLECTOR COMP.	H13	94	8
CIRCLIP, 5MM	G6	71	29		H16	97	1		H15	96	28
	G15	80	30	COLLAR, BEVEL GEAR	K11	140	56		K14	143	3
	J8	121	34	COLLAR, CONTROL BOX	K15	144	12				19
	J12	125	21	COLLAR, FUEL TANK	I10	107	10	DEFLECTOR, MUFFLER	H14	95	11
CIRCLIP, INTERNAL, 30MM	K11	140	63	COLLAR, LEVER	J3	116	9		H16	97	8
CLAMPER, CORD	I16	113	7		J12	125	4	DISK, CLUTCH FRICTION	J16	129	6
CLAMP D, 19MM	K13	142	5	COLLAR, STOPPER	J6	119	24	DOWEL PIN, 10X12	K11	140	60
CLAMP, CORD	G2	67	5		J10	123	7	DOWEL PIN, 10X16	E2	35	12
CLAMP, SWITCH CORD	E8	41	11	COLLAR, TANK CUSHION	I9	106	17	DOWEL PIN, 3X5.8	K10	139	43
CLAMP, TUBE	G7	72	35	COLLAR, WEIGHT CENTER	F4	53	21	DOWEL PIN, 8X10	K1	130	28
	I8	105	28	CONTROL ASSY.	J2	115	2		K11	140	59
			36				3	DOWEL PIN, 8X14	E9	42	18
	K14	143	10				4		J14	127	12
	K16	145	11				5		J15	128	11
CLAMP, TUBE, 7.5X2	I5	102	8		J10	123	5	DRIVER, SCREW	K7	136	4
CLEANER ASSY., AIR	H10	91	2		J11	124	5	DUST SEAL, 9X15X5	K11	140	49
CLIP A, WIRE	H10	91	4		J12	125	2				
CLIP B, TUBE	H2	83	1	CONTROL UNIT, ENGINE	K16	145	7	[E]			
	H10	91	1	CORD, STOP SWITCH	G3	68	11				
CLIP B, WIRE	H10	91	5	COVER ASSY., CHAIN CASE	J13	126	1	ELBOW COMP., AIR CLEANER	H4	85	10
CLIP, BEARING	K10	139	42		J15	128	1		H5	86	6
CLIP, GOVERNOR HOLDER	E6	39	15	COVER ASSY., CRANKCASE	E7	40	1		H7	88	8
CLIP, HARNESS	G4	69	18				2		H8	89	10
CLIP, PISTON PIN, 13MM	F1	50	6	COVER COMP., AIR CLEANER	H10	91	7		H10	91	12
CLIP, TUBE	E3	36	13	COVER COMP., FAN	G1	66	2	ELEMENT COMP., AIR CLEANER	H10	91	3
	E9	42	19	COVER COMP., HEAD	E2	35	6	ELEMENT, AIR CLEANER	H2	83	3
	I8	105	26	COVER COMP., MUFFLER	H14	95	12		H5	86	1
			27		H16	97	9		H7	88	6
			29	COVER COMP., MUFFLER RR.	H14	95	13		H8	89	2
	I9	106	20		H16	97	10		H11	92	2
	I10	107	13	COVER, AIR CLEANER	H3	84	5		K14	143	11
	I11	108	11		H5	86	3	EMBLEM	K4	133	8
	K15	144	15		H8	89	5	END, LOCK	J6	119	25
CLIP, VALVE GUIDE	E2	35	4				6				
CLIP, WATER HOSE	H10	91	14		H11	92	5	[F]			
	I6	103	20	COVER, GENERATOR FAN	K16	145	5	FAN, COOLING	I12	109	2
CLIP, WIRE HARNESS	G3	68	15	COVER, REDUCTION	J16	129	3		K16	145	6
	I8	105	31		K2	131	3	FILTER ASSY., SUCTION	K9	138	22
	K14	143	8	CRANKSHAFT COMP.	E10	43	1	FILTER COMP., FUEL	I6	103	14
COCK ASSY., FUEL	I9	106	3				2		I9	106	12
	K15	144	3				3	FILTER, CUP	I9	106	6
COIL ASSY., IGNITION	I15	112	1				4	FILTER, FUEL	I6	103	14
	I16	113	1				5				15
COIL ASSY., LAMP	I16	113	4				6		I10	107	9
			5				7		I11	108	6
			6				8				

PART NAME INDEX

N 3

Part name	Address	Page	Ref.	Part name	Address	Page	Ref.	Part name	Address	Page	Ref.
FILTER, FUEL	K15	144	8	HOLDER, CABLE	J9	122	39	LEVER, CONTROL	J4	117	14
FILTER, OUTER	H2	83	4		J12	125	11	LIFTER, VALVE	F2	51	6
	H8	89	3	HOLDER, CLUTCH SPRING	J16	129	10				
	H10	91	6	HOLDER, CLUTCH WEIGHT	J16	129	12	[M]			
	K14	143	12	HOLDER, CONTROL CABLE	G6	71	18	MARK A, COMBINATION	K4	133	7
FILTER, SUCTION	K9	138	23		G13	78	19	MARK B, COMBINATION	K4	133	12
FLOAT SET	G5	70	4	HOLDER, FUEL FILTER	I6	103	16	MARK, AIR CLEANER	K6	135	20
	G9	74	4	HOLDER, GOVERNOR WEIGHT	E5	38	5	MARK, AIR CLEANER CAUTION	K4	133	11
FLYWHEEL COMP.	I12	109	5	HOLDER, WIRE	J6	119	23	MARK, AIR CLEANER SALES POINT	K6	135	23
	I13	110	5		J12	125	16	MARK, CAUTION	K3	132	2
			6	HOUSING, TROCHOID	K9	138	21		K4	133	10
[G]									L1	146	1
GASKET KIT	L2	147	1	[I]				MARK, CHOKE	K4	133	13
GASKET SET	G5	70	2	INSULATOR, CARBURETOR	G6	71	14		K5	134	13
	G8	73	2		G12	77	15		L1	146	3
GASKET, CYLINDER HEAD	E2	35	5								4
GASKET, MUFFLER	H14	95	10	[J]				MARK, ENGINE OPERATION	K3	132	1
	H16	97	7	JET SET, PILOT,	G7	72	37	MARK, EX. CAUTION	K6	135	25
	I2	99	4		H1	82	36	MARK, FIRE DANGER	K4	133	9
	I3	100	8	JET, MAIN,	G7	72	36	MARK, FUEL CAUTION	K3	132	2
			9		G16	81	35	MARK, FUEL INDICATION	K6	135	27
	K14	143	15		H1	82	35	MARK, FUEL WARNING	K3	132	3
GAUGE ASSY., FUEL	I5	102	10	JOINT, DRAIN	K14	143	1	MARK, HEAT CAUTION	K6	135	24
GAUGE ASSY., THICKNESS	K7	136	6	JOINT, FUEL TANK	I5	102	7	MARK, OIL ALERT	K5	134	15
GEAR SET, MOTOR SHAFT & BEVEL	K9	138	12		I11	108	2		K6	135	17
GOVERNOR ASSY.	E5	38	3	JOINT, ROD	J2	115	1				18
GRID, AIR CLEANER	H5	86	2		J12	125	1				19
	H7	88	7	[K]				MARK, OIL CAUTION	K6	135	29
GRIP	K7	136	5	KEY, 4.78X4.78X38	E11	44	18	MARK, OPERATOR CAUTION	K6	135	32
GRIP, STARTER	F8	57	9	KEY, 5MM	J16	129	20		L1	146	6
	F14	63	10	KEY, 5X5X33	E11	44	18	MARK, THROTTLE INDICATION	K5	134	16
GROMMET, ADJUSTING COVER	G1	66	1	KEY, 7X7X33	J16	129	21		L1	146	5
GROMMET, AIR CLEANER	H3	84	6	KEY, SPECIAL WOODRUFF, 25X18 ..	I12	109	1	MARK, TOP	K3	132	1
	H8	89	7	KNOB, RECOIL STARTER	F10	59	14	MARK, USE FUEL	K6	135	28
	K14	143	13					METER ASSY., FUEL	I9	106	8
GROMMET, CORD	I16	113	8	[L]					K15	144	5
GROMMET, DRAIN HOLE	G3	68	12	LABEL, AIR CLEANER CAUTION	K6	135	21	MUFFLER ASSY.	H12	93	2
GUIDE, EX. VALVE	E1	34	2					MUFFLER COMP.	H12	93	3
GUIDE, GENERATOR AIR	K16	145	4								4
GUIDE, IN. VALVE	E1	34	1						H16	97	2
GUIDE, MUFFLER	H14	95	16	LABEL, CAUTION	K3	132	1		I2	99	1
	K14	143	4		L1	146	2	[N]	I3	100	1
GUIDE, PRE AIR CLEANER	H8	89	13	LABEL, E-SPEC	K3	132	4	NOSE, SILENCER	H3	84	7
GUIDE, RATCHET	F6	55	5		K3	132	6	NOZZLE, MAIN	G6	71	13
	F10	59	9	LABEL, SPEC	K3	132	6		G11	76	13
	F13	62	6	LABEL, SPECIFICATION	K5	134	14		G12	77	13
[H]				LABEL, WARNING	K6	135	31	NUT	F10	59	13
HANDLE, BOX WRENCH	K7	136	9	LEVER COMP., CHOKE	G6	71	20	NUT, CAP, 6MM	H6	87	8
HEAD COMP., CYLINDER	E1	34	3					NUT, FLANGE, 10MM	E6	39	19
HOLDER COMP., OIL SEAL	K9	138	4		G13	78	21		K14	143	9
HOLDER, BEARING	K9	138	7	LABEL, SPEC	G14	79	21	NUT, FLANGE, 6MM	H4	85	13
	K10	139	29	LABEL, SPECIFICATION					H6	87	12
HOLDER, CABLE	G6	71	23	LABEL, WARNING	K6	135	31		H7	88	11
	G14	79	24	LEVER COMP., CONTROL	J12	125	8		H9	90	20
	J5	118	17	LEVER, COCK	G6	71	25				
					G14	79	25				

4

PART NAME INDEX

N 4

Part name	Address	Page	Ref.	Part name	Address	Page	Ref.	Part name	Address	Page	Ref.
NUT, FLANGE, 6MM	H10	91	16	PACKING, AIR CLEANER COVER	H8	89	4	PLATE, FUEL INDICATION	I9	106	15
	H11	92	9	PACKING, CARBURETOR	G6	71	17		K6	135	26
	I2	99	6		G13	78	18	PLATE, LEVER SETTING	G6	71	26
	I3	100	12	PACKING, CASE COVER	E7	40	3		G14	79	26
	I6	103	22	PACKING, CHAIN CASE COVER	J13	126	2	PLATE, PRE AIR CLEANER	H8	89	14
	I10	107	11		J15	128	2		H9	90	15
	I11	108	9	PACKING, ELBOW	H2	83	2	PLATE, PUSH ROD GUIDE	F4	53	17
	J9	122	38		H7	88	1	PLATE, SIDE	G2	67	3
	J10	123	13		H8	89	1				4
	J11	124	11	PACKING, FUEL CAP	I10	107	8	PLUG, SPARK	E3	36	15
	J12	125	25	PACKING, FUEL COCK	G6	71	28		E4	37	15
NUT, FLANGE, 8MM	H15	96	24		G14	79	28	PROTECTOR, LOWER	H13	94	6
NUT, HEX., 5MM	H15	96	25	PACKING, FUEL FILLER CAP	I6	103	13	PROTECTOR, MUFFLER	H13	94	5
	I1	98	19		I8	105	33		H16	97	4
NUT, HEX., 6MM	H4	85	12				35	PROTECTOR, MUFFLER INNER	I3	100	3
NUT, HEX., 8MM	H15	96	24		I9	106	11	PROTECTOR, MUFFLER OUTER	I3	100	2
	I1	98	21		I11	108	5	PROTECTOR, OIL TUBE	K13	142	2
	I2	99	5		K15	144	7	PROTECTOR, TAIL PIPE	H13	94	7
	I3	100	11	PACKING, FUEL STRAINER CUP	G12	77	14	PROTECTOR, UPPER	H12	93	5
	K14	143	16		I9	106	1	PULLEY COMP., STARTER	I12	109	3
NUT, PIVOT ADJUSTING	F4	53	19	PACKING, HEAD COVER	E2	35	7		I13	110	8
NUT, SELF-LOCK, 6MM	J8	121	32	PACKING, INSULATOR	G6	71	15	PULLEY, RECOIL STARTER	F10	59	3
	J12	125	20		G12	77	16	PULLEY, STARTER	I12	109	4
NUT, SPECIAL, 14MM	I13	110	7	PACKING, OIL FILLER CAP	E8	41	9		I13	110	9
NUT, TOOL BOX SETTING	H4	85	11	PACKING, PUMP CASE	K9	138	15		I14	111	10
	H6	87	10	PACKING, REDUCTION CASE	J16	129	2	PULLEY, WHEEL DRIVEN	K9	138	5
	H7	88	10		K2	131	2				
	H9	90	18	PACKING, REDUCTION COVER	J16	129	4				
NUT, U, 6MM	H9	90	17		K2	131	4	[R]			
NUT, WING, 6MM	H6	87	9	PACKING, RR. TRANSMISSION CASE	K9	138	3	RATCHET, STARTER	F6	55	4
				PAN, CLEANER OIL	H7	88	5		F10	59	4
[O]				PIN B, DOWEL, 5X8	K11	140	61		F12	61	4
OIL SEAL	J16	129	22	PIN, GOVERNOR WEIGHT	E5	38	6	REEL, RECOIL STARTER	F6	55	3
OIL SEAL, 15X28X7	K11	140	50	PIN, LOCK, 4MM	K11	140	58		F12	61	3
OIL SEAL, 17X30X6	K11	140	48	PIN, LOCK, 8MM	E6	39	21	RETAINER, EX. VALVE SPRING	F4	53	15
OIL SEAL, 22X35X6	E6	39	17	PIN, NEUTRAL VALVE	K10	139	44	RETAINER, IN. VALVE SPRING	F4	53	14
OIL SEAL, 22X41X6	E9	42	16	PIN, PISTON	F1	50	3	RING SET, PISTON	E12	45	1
OIL SEAL, 25X38X7	J15	128	9	PIN, SPRING, 2X12	G7	72	33		E13	46	1
OIL SEAL, 25X41X6	J13	126	10		G16	81	34		E14	47	1
	K2	131	8	PIN, SPRING, 4X28	K11	140	62		E15	48	1
OIL SEAL, 30X50X7	J16	129	22	PIN, STARTER RATCHET	F10	59	5	RING, SEAL	K14	143	5
OIL SEAL, 6X11X4	E6	39	23	PIN, WEIGHT CENTER	F4	53	20	ROD ASSY., CONNECTING	F1	50	4
O-RING	I9	106	5	PIPE COMP., EX.	I3	100	5	ROD, GOVERNOR	J3	116	10
	K15	144	1	PISTON	E15	48	2				11
O-RING, 11X1.9	K11	140	53		E16	49	2		J10	123	2
O-RING, 11.8X1.9	K11	140	55	PISTON, PUMP	F1	50	2		J11	124	2
O-RING, 14MM	E6	39	18	PIVOT, ROCKER ARM	F2	51	7		J12	125	5
	I6	103	19	PLATE COMP., CLUTCH PRESSURE ..	J16	129	8	ROD, PUSH	F2	51	4
	I11	108	8	PLATE COMP., DISTRIBUTOR	K10	139	28	ROLLER, 2.5X11.8	K11	140	47
O-RING, 15.8X2.4	E9	42	17	PLATE COMP., SIDE	G2	67	3	ROPE, RECOIL STARTER	F8	57	10
O-RING, 25X2.4	K11	140	51						F10	59	15
O-RING, 26X2.7	J16	129	23	PLATE SET, MOTOR CYLINDER	K9	138	10		F14	63	11
O-RING, 34.6X1.9	K11	140	52	PLATE SET, PUMP CYLINDER	K9	138	9	ROPE, STARTER	F15	64	11
O-RING, 5.8X1.9	K11	140	54	PLATE, CLUTCH	J16	129	7	ROTATOR, VALVE	F4	53	16
				PLATE, FAN SETTING	K16	145	2	ROTOR, TROCHOID	K9	138	19
[P]				PLATE, FILTER CAP	K9	138	25	RUBBER, BOTTOM	E6	39	11
PACKING, AIR CLEANER	H11	92	1	PLATE, FRICTION	F10	59	6		I9	106	14
					F13	62	5		K16	145	8

PART NAME INDEX

N 5

Part name	Address	Page	Ref.	Part name	Address	Page	Ref.	Part name	Address	Page	Ref.
RUBBER, CONTROL BOX	K15	144	10	SCREW, RECESSED, 5X25	J7	120	30	SPRING, CABLE RETURN	J6	119	22
RUBBER, FR. BOTTOM	E6	39	9		J10	123	11		J11	124	7
RUBBER, FUEL	I6	103	18	SCREW, RECESSED, 5X28	J7	120	29		J12	125	15
	K15	144	11	SCREW, SETTING	F8	57	11	SPRING, CHECK VALVE	K10	139	32
RUBBER, RR. BOTTOM	E6	39	10		F15	64	12	SPRING, CLUTCH FREE	J16	129	9
RUBBER, SUPPORTER	G6	71	24	SCREW, TAPPING, 4X6	H14	95	22	SPRING, COCK LEVER	G6	71	27
	I4	101	3		H15	96	23		G14	79	27
			4				29	SPRING, CONTROL ADJUSTING	J6	119	21
	I8	105	30		H16	97	13		J10	123	6
	I9	106	2		I1	98	18		J11	124	6
	I10	107	1		K14	143	20		J12	125	14
	I11	108	1	SCREW, TAPPING, 4X8	H14	95	17	SPRING, FRICTION	F7	56	6
RUBBER, TANK CUSHION	I9	106	16		H16	97	13		F10	59	7
RUBBER, TANK MOUNTING	I9	106	13		K14	143	7	SPRING, GOVERNOR	F14	63	7
	K15	144	9	SCREW, TAPPING, 5X14	K16	145	9		J4	117	12
RUBBER, TANK SETTING	I10	107	2	SCREW, TAPPING, 5X18	K16	145	10		J10	123	3
			3	SCREW, TAPPING, 5X25	H14	95	21		J11	124	3
					I1	98	17		J12	125	6
[S]				SCREW, TAPPING, 5X8	H14	95	19	SPRING, LEVER	J4	117	15
							20		J12	125	9
SCREEN SET	K15	144	4		H16	97	15	SPRING, PISTON	K9	138	18
SCREEN, FUEL STRAINER	I9	106	4				16	SPRING, RECOIL STARTER	F7	56	7
SCREW-WASHER, 4X12	H9	90	19	SCREW, THROTTLE STOP	G6	71	12		F10	59	8
SCREW-WASHER, 6X20	H15	96	26		G11	76	12		F14	63	8
	I1	98	20	SEAL, AIR CLEANER	H11	92	7	SPRING, RELIEF VALVE	K10	139	26
SCREW SET	G5	70	9	SEAL, MUFFLER PROTECTOR	I3	100	4	SPRING, RETURN	F8	57	8
	G10	75	9	SEAL, RUBBER	K9	138	24		F14	63	9
SCREW SET, DRAIN	G5	70	8	SEAL, VALVE STEM	F2	51	1		G6	71	22
	G10	75	8	SEAT, RELIEF VALVE	K10	139	27		G14	79	23
	H1	82	38	SEPARATOR, AIR CLEANER	H11	92	3	SPRING, THROTTLE RETURN	J4	117	13
SCREW SET, PILOT	G5	70	6	SHAFT COMP., P.T.O.	J16	129	16		J10	123	4
			7	SHAFT, CROSS	K9	138	6		J11	124	4
	G9	74	6	SHAFT, GOVERNOR ARM	E5	38	8		J12	125	7
	G10	75	7	SHAFT, PUMP	K9	138	16	SPRING, THRUST	J13	126	7
SCREW, FLAT, 5X10	I6	103	21	SHAFT, P.T.O.	J13	126	5		J15	128	7
	I9	106	18		J14	127	14	SPRING, VALVE	F4	53	13
	K15	144	13		J15	128	5	SPRING, WEIGHT RETURN	F3	52	9
SCREW, LOCK PAN	J7	120	30		K2	131	5				10
	J8	121	33	SHAFT, SUB	F10	59	12	SPROCKET COMP., DRIVE	J16	129	14
SCREW, PAN, 3X6	G6	71	30	SHIM A, BEVEL GEAR	K10	139	41	SPROCKET, DRIVE	J13	126	4
	G15	80	31	SHIM B, BEVEL GEAR	K10	139	41		J15	128	4
	G16	81	31	SHIM C, BEVEL GEAR	K10	139	41	STARTER ASSY., RECOIL	F5	54	1
SCREW, PAN, 3X8	G15	80	31	SHIM D, BEVEL GEAR	K10	139	41		F10	59	1
SCREW, PAN, 4X20	H10	91	15	SHIM E, BEVEL GEAR	K10	139	41		F11	60	1
SCREW, PAN, 4X6	J8	121	35	SHIM F, BEVEL GEAR	K10	139	41	STAY COMP., MUFFLER	I2	99	2
	J12	125	22	SHROUD COMP.	G2	67	6				3
SCREW, PAN, 4X8	G6	71	31	SLIDER, GOVERNOR	E5	38	7	STAY, AIR CLEANER	H11	92	6
	G16	81	32	SPACER COMP., CARBURETOR	G6	71	16	STAY, CHOKE CONTROL	G6	71	19
SCREW, PAN, 5X16	J9	122	36		G12	77	17		G13	78	20
	J12	125	23		G13	78	17	STAY, CORD CLIP	E8	41	10
SCREW, PAN, 5X25	J8	121	30	SPACER, CONTROL LEVER	J5	118	18		G2	67	8
	J9	122	37		J12	125	12	STAY, FUEL TANK	I10	107	5
	J12	125	24	SPACER, MUFFLER COVER	H14	95	15	STAY, MUFFLER	H16	97	3
SCREW, PAN, 5X28	J11	124	10		H16	97	12		I3	100	6
SCREW, PAN, 5X30	J8	121	30	SPANNER, 10X12	K7	136	10	STRAINER COMP., FUEL	I4	101	5
SCREW, PAN, 5X35	J10	123	12	SPANNER, 10X14	K7	136	11				6
SCREW, PAN, 5X8	G6	71	32	SPANNER, 14X17	K7	136	12		K16	145	1
	G16	81	33	SPONGE, FUEL CAP BREATHER	I10	107	7	STRAINER, FUEL	K14	143	17
SCREW, RECESSED, 5X25	J7	120	29	SPOOL, NEUTRAL VALVE	K10	139	30	SUB HARNESS	G2	67	7

4

PART NAME INDEX

Part name	Address	Page	Ref.	Part name	Address	Page	Ref.	Part name	Address	Page	Ref.
SWITCH ASSY., ENGINE STOP	G2	67	10	WASHER, 8MM	J13	126	8				
	G4	69	17		J15	128	8				
SWITCH ASSY., OIL LEVEL	E5	38	2	WASHER, CAMSHAFT SIDE	K10	139	36				
				WASHER, CONTROL LEVER	J4	117	16				
[T]					J12	125	10				
TANK ASSY., FUEL	I5	102	9	WASHER, DRAIN PLUG, 10.2MM	E6	39	14				
TANK ASSY., OIL	E7	40	4		K14	143	18				
	K13	142	3	WASHER, DRAIN PLUG, 12MM	K1	130	26				
TANK COMP., FUEL	I5	102	11		K2	131	9				
	I6	103	11	WASHER, DRAIN PLUG, 14MM	K11	140	57				
	I9	106	9	WASHER, PLAIN, 15MM	K10	139	40				
	I10	107	4	WASHER, PLAIN, 5MM	H15	96	27				
	I11	108	3		I1	98	22				
TERMINAL ASSY., HIGH TENSION	I16	113	2	WASHER, PLAIN, 6MM	E6	39	20				
TOOL KIT	K7	136	2		H4	85	14				
	K8	137	14	WASHER, PLAIN, 8MM	I2	99	7				
TRANSMISSION ASSY.	K9	138	1	WASHER, SEALING, 9X16X1.5	K10	139	38				
TUBE	I4	101	2	WASHER, SPRING, 8MM	K1	130	27				
TUBE A, AIR VENT	I4	101	1	WASHER, STARTER	F10	59	11				
TUBE, 3.5X150	E9	42	20	WASHER, THRUST, 18MM	J16	129	19				
TUBE, AIR CLEANER CONNECTING	H10	91	10	WASHER, THRUST, 20MM	J15	128	6				
TUBE, BREATHER	E2	35	8	WASHER, THRUST, 6MM	E6	39	13				
TUBE, DRAIN	K14	143	2	WASHER, THRUST, 8MM	K10	139	39				
TUBE, FUEL	I7	104	25	WEIGHT COMP., DECOMPER	F2	51	8				
TUBE, FUEL, 4.5X110	I7	104	24	WEIGHT, CLUTCH	J16	129	11				
TUBE, FUEL, 4.5X140	G7	72	34	WEIGHT, GOVERNOR	E5	38	4				
	I7	104	25	WIRE, LOCK	J6	119	26				
	I10	107	12	WRENCH COMP., SPARK PLUG	K7	136	8				
	I11	108	10	WRENCH, BOX	K7	136	7				
							8				
TUBE, FUEL, 4.5X250	K15	144	14	WRENCH, PLUG	K7	136	7				
TUBE, FUEL, 4.5X300	I9	106	19								
TUBE, FUEL, 4.5X35	I6	103	23								
TUBE, FUEL, 4.5X350	I7	104	23								
			24								
TUBE, FUEL, 4.5X400	G7	72	34								
TUBE, FUEL, 4.5X75	I7	104	23								
			24								
TUBE, FUEL, 4.5X750	I7	104	25								
TUBE, OIL	K13	142	1								
TUBE, POWER TRIM-TILT SWITCH											
CORD	I4	101	4								
	I8	105	30								
TUBE, VINYL, 5X8X240	H1	82	39								
TUBE, VINYL, 5X8X400	H1	82	39								
[V]											
VALVE SET, FLOAT	G5	70	3								
	G8	73	3								
VALVE, EX.	F3	52	12								
	F4	53	12								
VALVE, IN.	F3	52	11								
VANE, TROCHOID	K9	138	20								
[W]											
WASHER, 6X17	K10	139	37								
WASHER, 8MM	E10	43	17								

1

FOREWORD INDEX

2

ENGINE GROUP

3

PART NUMBER INDEX

4

PART NAME INDEX

HONDA
The Power of Dreams



PARTS CATALOGUE NEWS

Honda Motor Co., Ltd. Service Division

PARTS CATALOGUE - CORRECTED

Printed in Japan

CODE NO.	13ZK7402
PARTS CATALOGUE NEWS	GX120K1 [GC01-430/910] [GC01B-100]
NEWS NO.	001

Block No.	Ref. No.	Note	Part No.	Description	Reqd. QTY				Serial No.	Parts catalogue code
					(1)	(2)	(3)	(4)		
E-26	11	E	92000-08025-0A	*PARTS NO. DELETION						
		T	92101-08025-0A	BOLT, HEX., 8X25	1	1	-	-	-----	DS, KRT, KRT4, KRT6, LAJ, LAJ4, LD, LH, LHQ4, LJ, LJC, LJC8, LJD2, LJS, LSJ, LSJ4, LTJ, LTK1, LTR, LTS, LX, LXU, LX2, LX4, L1
E-28	17	L	87532-ZH8-810	MARK, OIL ALERT (EXTERNAL) ...	1	-	-	-	-----	HTF2, HX, HXU, HX26, LJC8, LX, LXU, LX2, PX, PX2, QMX2, QWA4, QX, QXC9, QXS2, QXU, QX2, QX26, RX, SG24, SMW2, SM12, SSS2, SWX2, SX, SXS4, TX, TX2, TX26, UXU, VED1, VED6, VSX, VSX1, VX, VXU, WKD6, WKT2, WKT6, WME2
					1	-	-	-	-----	4465931 HX2
					-	1	-	-		

NOTE A:PART NO. CHANGE D:NEWLY PROVIDED E:PART NO.DELETION K:REQUIRED NO. CORRECTION L:APPLICATION SERIAL NO. CORRECTION
T:APPLICATION CORRECTION Z:REMARKS CHANGE

November 25, 2007



PARTS CATALOGUE NEWS

Honda Motor Co., Ltd. Service Division

PARTS CATALOGUE - CORRECTED

Printed in Japan

CODE NO.	13ZK7402
PARTS CATALOGUE NEWS	GX120K1 [GC01-430/910] [GC01B-100]
NEWS NO.	002

Block No.	Ref. No.	Note	Part No.	Description	Reqd. QTY				Serial No.	Parts catalogue code	
					(1)	(2)	(3)	(4)			
E-28	5	L	87135-ZE2-020	LABEL, E-SPEC (15.5X27.5)	1	-	-	-	-----	KRA4, KRF4, KRT4, RHC, VPR4	
					1	-	-	-	-----	4500394	DKR, KR, KRT, KRT6, QB26, VMT
					-	1	-	-	-----	4500394	

NOTE A:PART NO. CHANGE D:NEWLY PROVIDED E:PART NO.DELETION K:REQUIRED NO. CORRECTION L:APPLICATION SERIAL NO. CORRECTION
T:APPLICATION CORRECTION Z:REMARKS CHANGE



PARTS CATALOGUE NEWS

Honda Motor Co., Ltd. Service Division

PARTS CATALOGUE - CORRECTED

Printed in Japan

CODE NO.	13ZK7402
PARTS CATALOGUE NEWS	GX120K1 [GC01-430/910] [GC01B-100]
NEWS NO.	003

Block No.	Ref. No.	Note	Part No.	Description	Reqd. QTY	Serial No.	Parts catalogue code
					(1) (2) (3) (4)		

E-14-1 CARBURETOR (2)

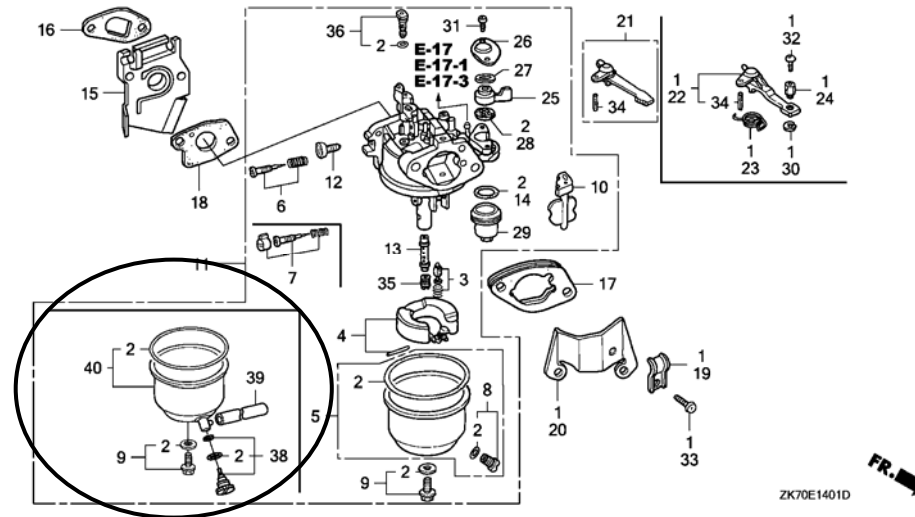

ZK70E1401D



E-14-1	37	E	16015-ZK7-S91	*PARTS NO. DELETION			
	40	D	16015-ZK7-S91	CHAMBER SET, FLOAT	1	- - - -	SYA

NOTE A:PART NO. CHANGE D:NEWLY PROVIDED E:PART NO.DELETION K:REQUIRED NO. CORRECTION L:APPLICATION SERIAL NO. CORRECTION
T:APPLICATION CORRECTION Z:REMARKS CHANGE

March 01, 2008



PARTS CATALOGUE NEWS

Honda Motor Co., Ltd. Service Division

Printed in Japan

CODE NO.	13ZK7402
PARTS CATALOGUE NEWS	GX120K1 [GC01-430/910] [GC01B-100]
NEWS NO.	004

GX120K1-VSX2 and WMK2 types sales information

NOTE: This Parts Catalogue News explains only the parts of the different model that are produced to conform to addition of the GX120K1-VSX2 and WMK2 types.

As for the parts not listed on this Parts Catalogue News, use the parts of the GX120K1-VSX1 and WMK types.

BOOKNo. : 13ZK7402

• **Models, parts catalogue codes and applicable serial numbers**

Model	Type		Parts catalogue type	Applicable engine serial No.	Applicable carburetor identification No.
GX120K1 (1)	VSX1	Base type	VSX1	GC01-4300001~	BE12A C
	VSX2	Additional type	VSX2		
	WMK	Base type	WMK		BE61D B
	WMK2	Additional type	WMK2		

BOOKNo. : 13ZK7402

• Features of each type		Base type	Additional type	Base type	Additional type
Specifications	Model	GX120K1			
	Type	Standard equipment (1)			
		VSX1	VSX2	WMK	WMK2
Crankshaft	18mm Ø Straight				
	19.05mm Ø Straight				
	20mm Ø Spline				
	21mm Ø Spline				
	19.8mm Ø Tapered	●	●		
	22mm Ø Tapered				
	3/4" Thread				
	5/8" Thread				
	M14 Stepped thread			●	●
	M16 Stepped thread				
	1/2" Stepped thread				
Reduction					
Fuel tank	●	●	●	●	
Oil alert	●	●			
Lamp coil					

PARTS CATALOGUE NEWS

BOOKNo. : 13ZK7402

Block No.	Ref. No.	Part No.	Description	Reqd. QTY				Base Part No.	Parts catalogue code
				(1)	(2)	(3)	(4)		
E-11-2	13		BOLT, FLANGE, 6X10	0	-	-	-	90008-ZE2-003	VSX2
E-17	11		TANK COMP., FUEL *R280*..... POWER RED	0	-	-	-	17510-ZE0-020ZL	VSX2

E-28 LABEL

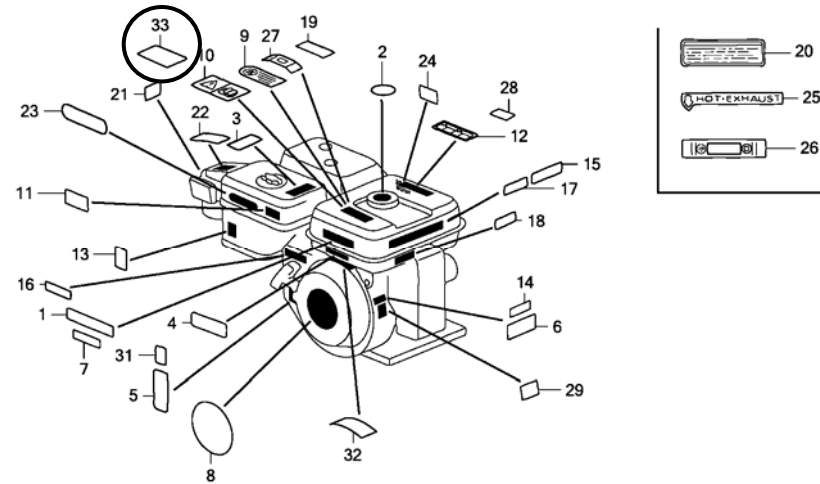

ZK70E2800D

E-28	1		LABEL, CAUTION (ENGLISH, ETC.)	0	-	-	-	87522-ZH9-010	VSX2
	8		EMBLEM (GX120)	0	-	-	-	87521-ZH7-040	VSX2
	10		MARK, CAUTION (PICTOGRAPH) ...	0	-	-	-	87522-ZH8-W41	WMK2
	33	87516-Z0D-800	MARK, OPERATOR CAUTION	1	-	-	-		

PARTS CATALOGUE NEWS

BOOKNo. : 13ZK7402

Block No.	Ref. No.	Part No.	Description	Reqd. QTY				Base Part No.	Parts catalogue code
				(1)	(2)	(3)	(4)		

E-40 OTHER PARTS (1)

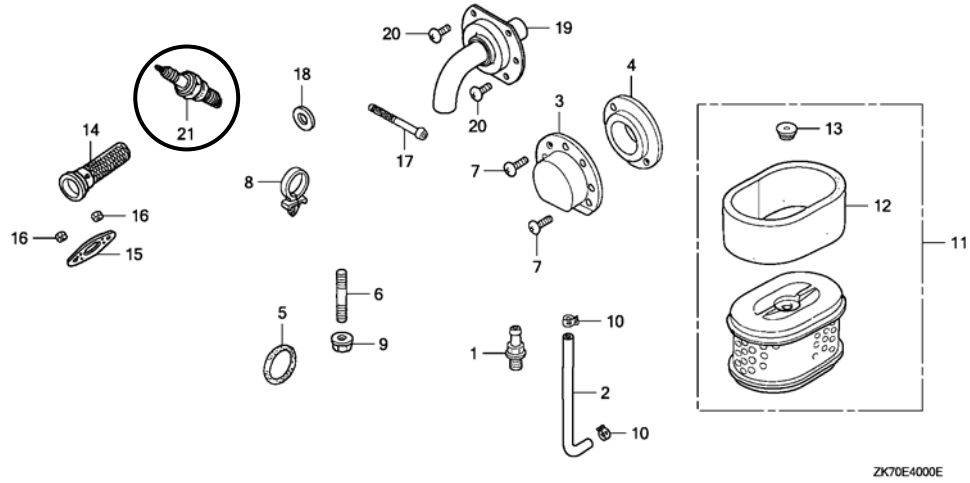

E-40	21	98079-56841	PLUG, SPARK (BP6ES) (NGK)	1	-	-	-	VSX2
------	----	-------------	-------------------------------------	---	---	---	---	------

PARTS CATALOGUE NEWS

BOOKNo. : 13ZK7402

Block No.	Ref. No.	Part No.	Description	Reqd. QTY				Base Part No.	Parts catalogue code
				(1)	GX120K1 (2)	(3)	(4)		
E-40-3			OTHER PARTS (4)						

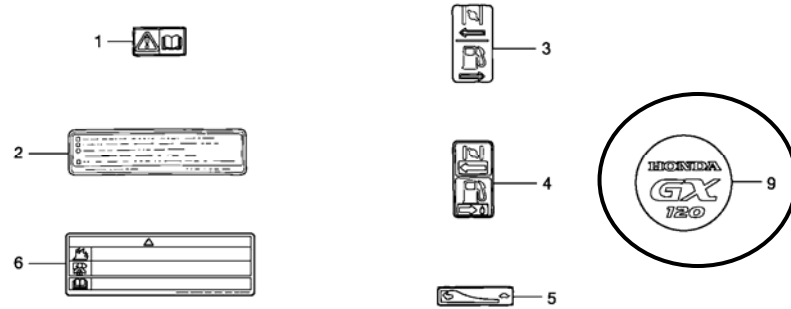

ZK70E4003B

E-40-3	9	87521-ZH7-040	EMBLEM (GX120)	1	-	-	-	VSX2
--------	---	---------------	----------------------	---	---	---	---	------



PARTS CATALOGUE NEWS

Honda Motor Co., Ltd. Service Division

PARTS CATALOGUE - CORRECTED

Printed in Japan

CODE NO.	13ZK7402
PARTS CATALOGUE NEWS	GX120K1 [GC01-430/910] [GC01B-100]
NEWS NO.	005

Block No.	Ref. No.	Note	Part No.	Description	Reqd. QTY				Serial No.	Parts catalogue code
					(1)	(2)	(3)	(4)		
E-2	3	K	12210-ZH7-415	HEAD COMP., CYLINDER	1	-	-	-	-----	ARL, VSX2, WMA4, WMK, WMK2
					1	-	-	-	4516044	AR, DKR, DS, HHQ4, HTF2, HT2, HT24, HX, HXU, HX2, HX26, HX4 KR, KRA4, KRF4, KRS4, KRS5, KRS6, KRT, KRT4, KRT6, LAJ, LAJ4 LD, LH, LHQ4, LJ, LJC, LJC8, LJD2, LJS, LSJ, LSJ4, LTJ, LTK1 LTR, LTS, LX, LXU, LX2, LX4, PX, PX2, QA, QA2, QB26, QD, QH QHQ4, QH26, QJG2, QLL, QM, QMA4, QMA8, QME4, QMX2, QT, QWA4 QX, QXC9, QXS2, QXU, QX2, QX26, QX4, QX7, RD, RD4, RHC, RHQ4 RX, RX4, SAJ, SAJ4, SAR4, SCJ, SD, SD16, SD4, SE, SG24, SH SHQ4, SJ, SJC1, SJC5, SJD2, SKR, SMA7, SMJ, SMW2, SM11, SM12 SM14, SSK1, SSK3, SSSX2, SSSX4, STP, STS, SWX2, SWX4, SX, SXS4 SX4, SX7, SYA, TX, TX2, TX26, TX4, UXU, VED, VED1, VED6, VEE1 VEK, VET, VEX, VEX7, VMS4, VMT, VPM4, VPR4, VSX, VSX1, VX VXU, VX4, VX7, WDA6, WD12, WJ, WJP, WKD6, WKT2, WKT4, WKT6 WMA3, WME2, WME4, WM1
					-	1	-	-	4516044	

NOTE A:PART NO. CHANGE D:NEWLY PROVIDED E:PART NO.DELETION K:REQUIRED NO. CORRECTION L:APPLICATION SERIAL NO. CORRECTION
T:APPLICATION CORRECTION Z:REMARKS CHANGE

PARTS CATALOGUE NEWS

BOOKNo. : 13ZK7402

Block No.	Ref. No.	Note	Part No.	Description	Reqd. QTY				Serial No.	Parts catalogue code
					(1)	(2)	(3)	(4)		

E-22 CONTROL (1)

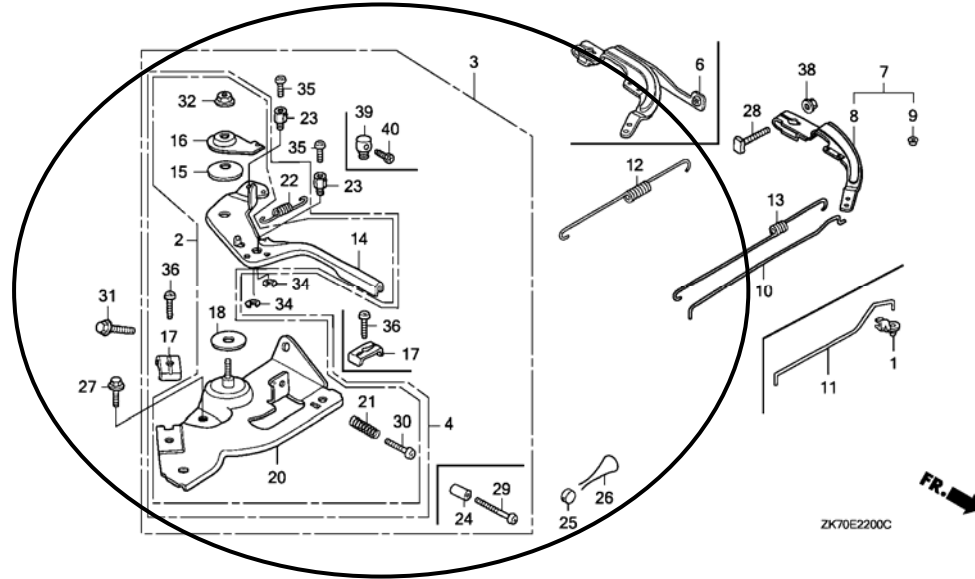

E-22	2	D	16500-ZH7-830	CONTROL ASSY. (LOCK TYPE)	-	(1)	-	-		
	5	E	16500-ZH7-830	*PARTS NO. DELETION						
	19	E	16580-ZH7-000	*PARTS NO. DELETION						
	20	D	16580-ZH7-000	BASE COMP., CONTROL (###)	1	-	-	1	-----	PX, PX2, TX, TXBR, TX2, TX26, TX4, UXU, VX, VXBR, VX4, VX7 WDA6, WD12, WMA3, WMA4, WME4, WMK, WMK2, WM1
					-	(1)	-	-		
	29	K	90016-ZE7-W00	SCREW, RECESSED, 5X28	1	-	-	-	-----	QLL
	30	T	90121-ZE0-000	SCREW, LOCK PAN	1	-	-	-	-----	VEE1
					-	(1)	-	-		

NOTE A:PART NO. CHANGE D:NEWLY PROVIDED E:PART NO.DELETION K:REQUIRED NO. CORRECTION L:APPLICATION SERIAL NO. CORRECTION
T:APPLICATION CORRECTION Z:REMARKS CHANGE

PARTS CATALOGUE NEWS

BOOKNo. : 13ZK7402

Block No.	Ref. No.	Note	Part No.	Description	Reqd. QTY				Serial No.	Parts catalogue code
					(1)	GX120K1 (2)	(3)	(4)		
		T	93500-05025-0H	SCREW, PAN, 5X25	1	-	-	-	-----	AR, ARL, DKR, DS, HHQ4, HTF2, HT2, HT24, HX, HXU, HX2, HX26 HX4, KR, KRA4, KRF4, KRS4, KRT, KRT4, KRT6, LAJ, LAJ4, LD, LH LHQ4, LJ, LJC, LJC8, LJS, LSJ, LSJ4, LTJ, LTK1, LTR, LX, LXU LX2, LX4, PX, PX2, QA, QA2, QB26, QD, QH, QHQ4, QH26, QJG2, QM QMA4, QMA8, QME4, QMX2, QT, QWA4, QX, QXC9, QXS2, QXU, QX2 QX26, QX4, QX7, RD, RD4, RHC, RHQ4, RX, RX4, SAJ, SAJ4, SAR4 SCJ, SD, SD16, SD4, SE, SG24, SH, SHQ4, SJ, SJC1, SJC5, SKR SMA7, SMJ, SMW2, SM11, SM12, SM14, SSK1, SSK3, SSX2, SSX4 STP, STS, SWX2, SWX4, SX, SXS4, SX4, SX7, SYA, TX, TX2, TX26 TX4, UXU, VET, VX, VX4, VX7, WDA6, WD12, WJ, WJP, WKD6, WKT2 WKT4, WKT6, WMA3, WMA4, WME2, WME4, WMK, WMK2, WM1
					-	(1)	1	1		
	33	E	90121-ZE0-000	*PARTS NO. DELETION						
	37	E	93500-05025-0H	*PARTS NO. DELETION						
E-28	17	T	87532-ZH8-810	MARK, OIL ALERT (ENGLISH)	1	-	-	-	-----	HTF2, HX, HXU, HX26, LJC8, LX, LXU, LX2, PX, PX2, QMX2, QWA4 QX, QXC9, QXS2, QXU, QX2, QX26, RX, SG24, SMW2, SM12, SSX2 SWX2, SX, SXS4, TX, TX2, TX26, UXU, VED1, VED6, VX, VXU, WKD6 WKT2, WKT6
					1	-	-	-	-----	4465931 HX2
					-	1	-	-		

NOTE A:PART NO. CHANGE D:NEWLY PROVIDED E:PART NO.DELETION K:REQUIRED NO. CORRECTION L:APPLICATION SERIAL NO. CORRECTION
T:APPLICATION CORRECTION Z:REMARKS CHANGE



PARTS CATALOGUE NEWS

Honda Motor Co., Ltd. Service Division

PARTS CATALOGUE - CORRECTED

Printed in Japan

CODE NO.	13ZK7402
PARTS CATALOGUE NEWS	GX120K1 [GC01-430/910] [GC01B-100]
NEWS NO.	006

Block No.	Ref. No.	Note	Part No.	Description	Reqd. QTY				Serial No.	Parts catalogue code
					(1)	(2)	(3)	(4)		
E-14-1	35	T	99101-ZH8-0550	JET, MAIN, #55	(1)	-	-	(1)	-----	HHQ4, HTF2, HT2, HT24, HX, HXU, HX2, HX26, HX4, LAJ4, LH LHQ4, LJD2, LTJ, LTS, LX, LXU, LX2, LX4, PX, PX2, QA, QB26, QH QHQ4, QH26, QJG2, QLL, QMA4, QMA8, QMX2, QWA4, QX, QXBR QXS2, QXU, QX2, QX26, QX4, QX7, RHC, RHQ4, RX, RX4, SAJ4 SAR4, SG24, SH, SHQ4, SJD2, SMA7, SMJ, SMW2, SM11, SM12 SM14, SSK1, SSK3, SSSX2, SSSX4, STP, SWX2, SWX4, SX, SXS4, SX4 SX7, TX, TXBR, TX2, TX26, TX4, UXU, VEE1, VEK, VEX, VEX7 VMS4, VSX, VSX1, VSX2, VX, VXBR, VXU, VX4, VX7, WDA6
					-	(1)	-	-		
		T	99101-ZH8-0580	JET, MAIN, #58	(1)	-	(1)	(1)	-----	DS, HHQ4, HTF2, HT2, HT24, HX, HXU, HX2, HX26, HX4, LAJ, LAJ4 LH, LHQ4, LJ, LJC, LJC8, LJD2, LJS, LSJ, LTJ, LTK1, LTR, LTS LX, LXU, LX2, LX4, PX, PX2, QA, QA2, QH, QHQ4, QH26, QJG2, QLL QMA4, QMA8, QME4, QMX2, QT, QWA4, QX, QXBR, QXC9, QXS2, QXU QX2, QX26, QX4, QX7, RHC, RHQ4, RX, RX4, SAJ, SAJ4, SAR4, SCJ SG24, SH, SHQ4, SJ, SJC1, SJC5, SJD2, SKR, SMA7, SMJ, SMW2 SM11, SM12, SM14, SSK1, SSK3, SSSX2, SSSX4, STP, STS, SWX2 SWX4, SX, SXS4, SX4, SX7, TX, TXBR, TX2, TX26, TX4, UXU, VED VED1, VED6, VEE1, VEK, VET, VEX, VEX7, VMS4, VMT, VPM4, VPR4 VSX, VSX1, VSX2, VX, VXBR, VXU, VX4, VX7, WDA6, WD12, WIS, WJ WJP, WKD6, WKT2, WKT4, WKT6, WME2
					-	(1)	-	-		
				(CARBURETOR NO.)	-	-	(1)	-	BE12A B	SIH, WIH
		T	99101-ZH8-0620	JET, MAIN, #62	1	-	1	-	-----	DS, LAJ, LJ, LJC, LJC8, LJS, LSJ, LTK1, LTR, QA2, QME4, QT QXC9, SAJ, SCJ, SJ, SJC1, SJC5, SKR, STS, VED, VED1, VED6 VET, VMT, VPM4, VPR4, WD12, WIS, WJ, WJP, WKD6, WKT2, WKT4 WKT6, WME2

NOTE A:PART NO. CHANGE D:NEWLY PROVIDED E:PART NO.DELETION K:REQUIRED NO. CORRECTION L:APPLICATION SERIAL NO. CORRECTION
T:APPLICATION CORRECTION Z:REMARKS CHANGE

PARTS CATALOGUE NEWS

BOOKNo. : 13ZK7402

Block No.	Ref. No.	Note	Part No.	Description	Reqd. QTY				Serial No.	Parts catalogue code
					(1)	GX120K1 (2)	(3)	(4)		
					(1)	-	-	-	-----	QB26
				(CARBURETOR NO.)	-	-	1	-	BE60L A -----	SIH, WIH
		D	99101-ZH8-0650	JET, MAIN, #65	(1)	-	-	-	-----	QB26

NOTE A:PART NO. CHANGE D:NEWLY PROVIDED E:PART NO.DELETION K:REQUIRED NO. CORRECTION L:APPLICATION SERIAL NO. CORRECTION
T:APPLICATION CORRECTION Z:REMARKS CHANGE



PARTS CATALOGUE NEWS

Honda Motor Co., Ltd. Service Division

PARTS CATALOGUE - CORRECTED

Printed in Japan

CODE NO.	13ZK7402
PARTS CATALOGUE NEWS	GX120K1 [GC01-430/910] [GC01B-100]
NEWS NO.	007

Block No.	Ref. No.	Note	Part No.	Description	Reqd. QTY (1) GX120K1 (2) (3) (4)	Serial No.	Parts catalogue code
-----------	----------	------	----------	-------------	---	------------	----------------------

E-3 CYLINDER BARREL

Ref. No.	(Relative ref. Number)	Description	FRT
2	(18, 24)	SWITCH, OIL LEVEL	0.5

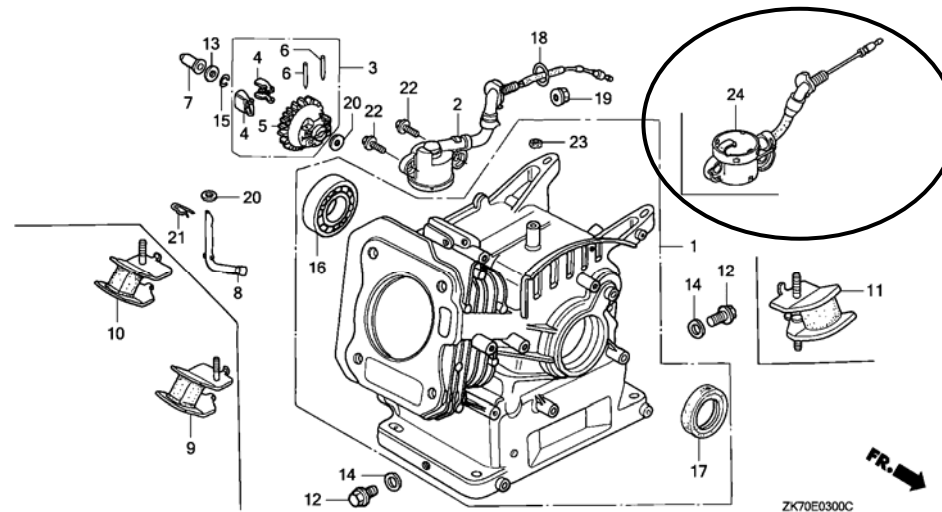

E-3	2	L	15510-ZE1-043	SWITCH ASSY., OIL LEVEL	1	- - -	4624687	VSX2
					1	- - -	4572371 4624687	HX, LJC, LJC8, QX, RX, SJC1, SJC5, SMJ, SX, VSX, VSX1
					-	(1) - -	4572371	H1, L1, Q1, R1, S1

NOTE A:PART NO. CHANGE D:NEWLY PROVIDED E:PART NO. DELETION K:REQUIRED NO. CORRECTION L:APPLICATION SERIAL NO. CORRECTION
T:APPLICATION CORRECTION Z:REMARKS CHANGE

PARTS CATALOGUE NEWS

BOOKNo. : 13ZK7402

Block No.	Ref. No.	Note	Part No.	Description	Reqd. QTY				Serial No.	Parts catalogue code
					(1)	GX120K1 (2)	(3)	(4)		
	24	D	35480-Z0T-003	SWITCH ASSY., OIL LEVEL	1	-	-	-	4624688 -----	HX, LJC, LJC8, QX, RX, SJC1, SJC5, SMJ, SX, VSX, VSX1, VSX2

NOTE A:PART NO. CHANGE D:NEWLY PROVIDED E:PART NO.DELETION K:REQUIRED NO. CORRECTION L:APPLICATION SERIAL NO. CORRECTION
T:APPLICATION CORRECTION Z:REMARKS CHANGE



PARTS CATALOGUE NEWS

Honda Motor Co., Ltd. Service Division

PARTS CATALOGUE - CORRECTED

Printed in Japan

CODE NO.	13ZK7402
PARTS CATALOGUE NEWS	GX120K1 [GC01-430/910] [GC01B-100]
NEWS NO.	008

Block No.	Ref. No.	Note	Part No.	Description	Reqd. QTY				Serial No.	Parts catalogue code	
					(1)	(2)	(3)	(4)			
E-2	14	L	95723-08055-00	BOLT, FLANGE, 8X55	4	-	-	-	-----	AR, DKR, HHQ4, HTF2, HT2, HT24, HXU, HX2, HX26, HX4, KRA4, KRF4, KRS4, KRS5, KRS6, KRT4, LAJ4, LHQ4, LJD2, LSJ4, LXU, LX2, LX4, PX2, QA2, QHQ4, QH26, QJG2, QLL, QMA4, QMA8, QME4, QMX2, QWA4, QXC9, QXS2, QXU, QX2, QX26, QX4, QX7, RD4, RHC, RHQ4, RX4, SAJ4, SAR4, SAR4, SD16, SD4, SE, SG24, SHQ4, SJD2, SMA7, SMW2, SM12, SM14, SSS2, SSS4, SWX2, SWX4, SXS4, SX4, SX7, TX2, TX26, TX4, UXU, VED6, VEX, VEX7, VMS4, VPM4, VPR4, VXU, VX4, VX7, WDA6, WD12, WKD6, WKT2, WKT4, WKT6, WMA3, WME2, WME4	
					4	-	-	-	-----	4532609	DS, HX, KR, KRT, KRT6, LAJ, LD, LH, LJ, LJC, LJC8, LJS, LSJ, LTJ, LTK1, LTR, LTS, LX, PX, QA, QB26, QD, QH, QM, QT, QX, RD, RX, SAJ, SCJ, SD, SH, SJ, SJC1, SJC5, SKR, SMJ, SM11, SSK1, SSK3, STP, STS, SX, SYA, TX, VED, VED1, VEE1, VEK, VET, VMT, VSX, VSX1, VX, WJ, WJP, WMK, WM1
					4	-	-	-	-----	4621598	ARL, WMA4
					-	4	-	-	-----	4532609	
					-	-	4	4			
	T		95701-08055-00	4	-	-	-----	VSX2, WMK2		
					4	-	-	-----	4532610	DS, HX, KR, KRT, KRT6, LAJ, LD, LH, LJ, LJC, LJC8, LJS, LSJ, LTJ, LTK1, LTR, LTS, LX, PX, QA, QB26, QD, QH, QM, QT, QX, RD, RX, SAJ, SCJ, SD, SH, SJ, SJC1, SJC5, SKR, SMJ, SM11, SSK1, SSK3, STP, STS, SX, SYA, TX, VED, VED1, VEE1, VEK, VET, VMT, VSX, VSX1, VX, WJ, WJP, WMK, WM1	
					4	-	-	-----	4621599	ARL, WMA4	

NOTE A:PART NO. CHANGE D:NEWLY PROVIDED E:PART NO. DELETION K:REQUIRED NO. CORRECTION L:APPLICATION SERIAL NO. CORRECTION
T:APPLICATION CORRECTION Z:REMARKS CHANGE

PARTS CATALOGUE NEWS

BOOKNo. : 13ZK7402

Block No.	Ref. No.	Note	Part No.	Description	Reqd. QTY				Serial No.	Parts catalogue code
					(1)	GX120K1 (2)	(3)	(4)		
					-	4	-	-	4532610	

NOTE A:PART NO. CHANGE D:NEWLY PROVIDED E:PART NO.DELETION K:REQUIRED NO. CORRECTION L:APPLICATION SERIAL NO. CORRECTION
T:APPLICATION CORRECTION Z:REMARKS CHANGE

December 21, 2008



PARTS CATALOGUE NEWS

Honda Motor Co., Ltd. Service Division

PARTS CATALOGUE - CORRECTED

Printed in Japan

CODE NO.	13ZK7402
PARTS CATALOGUE NEWS	GX120K1 [GC01-430/910] [GC01B-100]
NEWS NO.	009

Block No.	Ref. No.	Note	Part No.	Description	Reqd. QTY				Serial No.	Parts catalogue code
					(1)	(2)	(3)	(4)		
E-2	5	D	12251-ZOS-801	GASKET, CYLINDER HEAD (THAI LEAKLESS)	(1)	(2)	(3)	(4)	-----	ARL

NOTE A:PART NO. CHANGE D:NEWLY PROVIDED E:PART NO.DELETION K:REQUIRED NO. CORRECTION L:APPLICATION SERIAL NO. CORRECTION
T:APPLICATION CORRECTION Z:REMARKS CHANGE

January 18, 2009



PARTS CATALOGUE NEWS

Honda Motor Co., Ltd. Service Division

PARTS CATALOGUE - CORRECTED

Printed in Japan

CODE NO.	13ZK7402
PARTS CATALOGUE NEWS	GX120K1 [GC01-430/910] [GC01B-100]
NEWS NO.	010

Block No.	Ref. No.	Note	Part No.	Description	Reqd. QTY				Serial No.	Parts catalogue code
					(1)	(2)	(3)	(4)		
E-28	17		87532-ZH8-000	MARK, OIL ALERT	1	1	-	-	-----	VEE1, W1
					1	1	-	-	-----	4641769 H1, LJC, L1, Q1, R1, SJC1, SJC5, SMJ, S1
	A	87530-ZL8-810	1	1	-	-	4641770	-----	H1, LJC, L1, Q1, R1, SJC1, SJC5, SMJ, S1

NOTE A:PART NO. CHANGE D:NEWLY PROVIDED E:PART NO.DELETION K:REQUIRED NO. CORRECTION L:APPLICATION SERIAL NO. CORRECTION
T:APPLICATION CORRECTION Z:REMARKS CHANGE



PARTS CATALOGUE NEWS

Honda Motor Co., Ltd. Service Division

PARTS CATALOGUE - CORRECTED

Printed in Japan

CODE NO.	13ZK7402
PARTS CATALOGUE NEWS	GX120K1 [GC01-430/910] [GC01B-100]
NEWS NO.	011

Block No.	Ref. No.	Note	Part No.	Description	Reqd. QTY				Serial No.	Parts catalogue code
					(1)	GX120K1 (2)	(3)	(4)		
E-28	31	T	87114-ZH7-000	LABEL, WARNING (NOT CERTIFIED FOR SALE)	1	-	-	-	-----	ARL, VSX2, WMA4, WMK, WMK2
					1	-	-	-	4452742	HX, KR, KRT, KRT6, LAJ, LD, LH, LJ, LJC, LJS, LSJ, LTK1, LTR LTS, LX, PX, QD, QH, QM, QT, QX, RD, RX, SAJ, SD, SH, SJ, SJC5 SKR, SMJ, SM11, SX, TX, VEE1, VEK, VET, VMT, VX, WJ, WM1
					1	-	-	-	4497136	DS, LJC8, LTJ, QA, SCJ, SJC1, SSK1, STP, STS, VED, VED1, VSX VSX1, WJP
					1	-	-	-	4508213	SSK3
					1	-	-	-	4644386	SYA
					-	1	-	-	4452742	

NOTE A:PART NO. CHANGE D:NEWLY PROVIDED E:PART NO. DELETION K:REQUIRED NO. CORRECTION L:APPLICATION SERIAL NO. CORRECTION
T:APPLICATION CORRECTION Z:REMARKS CHANGE



PARTS CATALOGUE NEWS

Honda Motor Co., Ltd. Service Division

PARTS CATALOGUE - CORRECTED

Printed in Japan

CODE NO.	13ZK7402
PARTS CATALOGUE NEWS	GX120K1 [GC01-430/910] [GC01B-100]
NEWS NO.	012

Block No.	Ref. No.	Note	Part No.	Description	Reqd. QTY				Serial No.	Parts catalogue code	
					(1)	(2)	(3)	(4)			
E-20	1	T	30500-ZE1-033	COIL ASSY., IGNITION	-	-	-	1	-----	TXBR, VXBR	
			30500-ZE1-043	1	-	-	-	-----	4450768	AR, DKR, DS, HHQ4, HTF2, HT2, HX, HXU, HX2, HX26, HX4, KR, KRA4, KRF4, KRS4, KRS5, KRS6, KRT, KRT4, KRT6, LAJ, LAJ4, LD, LH, LHQ4, LJ, LJC, LJC8, LJD2, LJS, LSJ, LSJ4, LTJ, LTK1, LTR, LTS, LX, LXU, LX2, LX4, PX, PX2, QA, QA2, QB26, QD, QH, QHQ4, QH26, QJG2, QLL, QM, QMA4, QMA8, QME4, QMX2, QT, QWA4, QX, QXC9, QXS2, QXU, QX2, QX26, QX4, QX7, RD, RD4, RHC, RHQ4, RX, RX4, SAJ, SAJ4, SCJ, SD, SD16, SD4, SE, SG24, SH, SHQ4, SJ, SJC1, SJC5, SJD2, SKR, SMA7, SMJ, SMW2, SM11, SM12, SM14, SSK1, SSK3, SSS2, SSS4, STP, STS, SWX2, SWX4, SX, SXS4, SX4, SX7, TX, TX2, TX26, TX4, UXU, VED, VED1, VED6, VEE1, VEK, VET, VEX, VEX7, VMS4, VMT, VPM4, VPR4, VSX, VSX1, VX, VXU, VX4, VX7, WDA6, WD12, WJ, WJP, WKD6, WKT2, WKT4, WKT6, WMA3, WME2, WME4, WM1
					-	(1)	-	-	-----	4450768	
						-	-	1	-----	-----	QDBR, QXBR
		T	30500-ZE1-073	1	-	-	-	-----	VSX2, WMK2	
					1	-	-	-	4569509	-----	ARL, DS, HX, KR, KRT, KRT6, LAJ, LH, LJ, LJC, LJC8, LJS, LTJ, LTK1, LTR, LTS, LX, PX, QB26, QH, QM, QX, RX, SAJ, SCJ, SD, SJC1, SJC5, SKR, SMJ, SM11, SSK3, STP, STS, SX, SYA, VED, VEK, VMT, VSX, VSX1, VX, WJ, WMA4, WMK
					-	(1)	-	-	4569509		
					-	-	1	-			

NOTE A:PART NO. CHANGE D:NEWLY PROVIDED E:PART NO. DELETION K:REQUIRED NO. CORRECTION L:APPLICATION SERIAL NO. CORRECTION
T:APPLICATION CORRECTION Z:REMARKS CHANGE

July 26, 2009



PARTS CATALOGUE NEWS

Honda Motor Co., Ltd. Service Division

PARTS CATALOGUE - CORRECTED

Printed in Japan

CODE NO.	13ZK7402
PARTS CATALOGUE NEWS	GX120K1 [GC01-430/910] [GC01B-100]
NEWS NO.	013

Block No.	Ref. No.	Note	Part No.	Description	Reqd. QTY				Serial No.	Parts catalogue code
					(1)	GX120K1 (2)	(3)	(4)		
E-16	2		18300-ZH8-840	MUFFLER ASSY.	1	-	-	-	-----	LSJ, QXS2, VET, WJP
				(LOWER PROTECTOR)	1	-	-	-	-----	4661867
	A		18300-ZH8-841	MUFFLER ASSY.	1	-	-	-	4661868	DS, LAJ, LJ, LJC, LJC8, LJS, LTJ, LTK1, LTR, LTS, SAJ, SCJ, SJ SJC1, SJC5, SKR, SMJ, WJ
				(LOWER PROTECTOR)						

NOTE A:PART NO. CHANGE D:NEWLY PROVIDED E:PART NO.DELETION K:REQUIRED NO. CORRECTION L:APPLICATION SERIAL NO. CORRECTION
T:APPLICATION CORRECTION Z:REMARKS CHANGE



PARTS CATALOGUE NEWS

Honda Motor Co., Ltd. Service Division

PARTS CATALOGUE - CORRECTED

Printed in Japan

CODE NO.	13ZK7402
PARTS CATALOGUE NEWS	GX120K1 [GC01-430/910] [GC01B-100]
NEWS NO.	014

Block No.	Ref. No.	Note	Part No.	Description	Reqd. QTY				Serial No.	Parts catalogue code	
					(1)	(2)	(3)	(4)			
E-11-2	1		28400-ZH8-023YA	STARTER ASSY., RECOIL *R280*.....POWER RED	1	(1)	-	-	4363434	-----	AR, DKR, HHQ4, HTF2, HT2, HXU, HX2, HX26, HX4, KRA4, KRF4 KRS4, KRS5, KRS6, KRT4, LD, LHQ4, LSJ, LSJ4, LX, LXU, LX2 LX4, PX, QA, QA2, QD, QHQ4, QH26, QLL, QM, QMA4, QMA8, QME4 QMX2, QXC9, QXS2, QXU, QX2, QX26, QX4, QX7, RD, RD4, RHC RHQ4, RX4, SAJ4, SD16, SD4, SE, SH, SHQ4, SMA7, SMW2, SXS4 SX4, SX7, TX, TX2, TX26, TX4, UXU, VED1, VET, VEX, VEX7, VMS4 VMT, VPM4, VPR4, VX, VXU, VX4, VX7, WDA6, WD12, WJP, WKD6 WKT2, WKT4, WKT6, WMA3, WME2, WME4, WM1, W1
					1	(1)	-	-	4363434	4657598	DS, HX, H1, KR, KRT, KRT6, LH, LJ, LJC, LJS, LTJ, LTK1, LTR LTS, L1, QH, QX, Q1, RX, R1, SAJ, SCJ, SD, SJ, SJC1, SJC5, SKR SMJ, STP, STS, SX, S1, VED, VSX, VSX1, WJ
					1	-	-	-	-----	-----	SAR4
					1	-	-	-	-----	4657598	ARL, LJC8, VSX2, WMA4, WMK, WMK2
					-	-	1	1			
			28400-ZH8-023ZB	*NH1*.....BLACK	1	(1)	-	-	4363434	-----	AR, HX2, H1, L1, PX2, QMX2, QWA4, QXC9, QXS2, QXU, QX2, R1 SG24, SM12, SM14, SSK1, SSX2, SSX4, TX4, VED1, VED6, VEE1, W1
					1	(1)	-	-	4363434	4657598	KR, Q1, SM11, SSK3, S1, VED, VSX, VSX1
					1	-	-	-	-----	-----	HT24
					1	-	-	-	-----	4657598	ARL, SYA, VSX2
			28400-ZH8-023ZK	*NH31*.....MCKINLEY WHITE	1	-	-	-	4363434	4657598	VEK

NOTE A:PART NO. CHANGE D:NEWLY PROVIDED E:PART NO.DELETION K:REQUIRED NO. CORRECTION L:APPLICATION SERIAL NO. CORRECTION
T:APPLICATION CORRECTION Z:REMARKS CHANGE

PARTS CATALOGUE NEWS

BOOKNo. : 13ZK7402

Block No.	Ref. No.	Note	Part No.	Description	Reqd. QTY				Serial No.	Parts catalogue code
					(1)	(2)	(3)	(4)		
			28400-ZH8-023ZV	*T79*..... BOMBARDIER YELLOW	1	-	-	-	4363434 4657598	QB26
			28400-ZH8-023ZW	*T80*..... BAKELITE ORANGE	1	-	-	-	----- 4657598	VSX2
					1	-	-	-	4363434 4657598	VSX, VSX1
		A	28400-ZH8-033YA	*R280*..... POWER RED	1	(1)	-	-	4657599 -----	ARL, DS, HX, H1, KR, KRT, KRT6, LH, LJ, LJC, LJC8, LJS, LTJ LTK1, LTR, LTS, L1, QH, QX, Q1, RX, R1, SAJ, SCJ, SD, SJ, SJC1 SJC5, SKR, SMJ, STP, STS, SX, S1, VED, VSX, VSX1, VSX2, WJ WMA4, WMK, WMK2
		A	28400-ZH8-033ZB	*NH1*..... BLACK	1	(1)	-	-	4657599 -----	ARL, KR, Q1, SM11, SSK3, SYA, S1, VED, VSX, VSX1, VSX2
		A	28400-ZH8-033ZK	*NH31*..... MCKINLEY WHITE	1	-	-	-	4657599 -----	VEK
		A	28400-ZH8-033ZV	*T79*..... BOMBARDIER YELLOW	1	-	-	-	4657599 -----	QB26
		A	28400-ZH8-033ZW	*T80*..... BAKELITE ORANGE	1	-	-	-	4657599 -----	VSX, VSX1, VSX2
	10		28461-ZH8-003	GRIP, STARTER	1	(1)	-	-	4363434 -----	AR, DKR, HHQ4, HTF2, HT2, HXU, HX2, HX26, HX4, KRA4, KRF4 KRS4, KRS5, KRS6, KRT4, LAJ4, LD, LHQ4, LJD2, LSJ, LSJ4, LX LXU, LX2, LX4, PX, PX2, QA, QA2, QD, QHQ4, QH26, QJG2, QLL, QM QMA4, QMA8, QME4, QMX2, QWA4, QXC9, QXS2, QXU, QX2, QX26 QX4, QX7, RD, RD4, RHC, RHQ4, RX4, SAJ4, SD16, SD4, SE, SG24 SH, SHQ4, SJD2, SMA7, SMW2, SM12, SM14, SSK1, SSS2, SSS4 SWX2, SWX4, SXS4, SX4, SX7, TX, TX2, TX26, TX4, UXU, VED1 VED6, VEE1, VET, VEX, VEX7, VMS4, VMT, VPM4, VPR4, VX, VXU VX4, VX7, WDA6, WD12, WJP, WKD6, WKT2, WKT4, WKT6, WMA3 WME2, WME4, WM1, W1
					1	(1)	-	-	4363434 4657598	DS, HX, H1, KR, KRT, KRT6, LAJ, LH, LJ, LJC, LJS, LTJ, LTK1 LTR, LTS, L1, QB26, QH, QX, Q1, RX, R1, SAJ, SCJ, SD, SJ, SJC1 SJC5, SKR, SMJ, SM11, SSK3, STP, STS, SX, S1, VED, VEK, VSX VSX1, WJ
					1	-	-	-	----- -----	HT24, SAR4
					1	-	-	-	----- 4657598	ARL, LJC8, SYA, VSX2, WMA4, WMK, WMK2
					-	-	1	1		
		A	28461-ZH8-013	1	(1)	-	-	4657599 -----	ARL, DS, HX, H1, KR, KRT, KRT6, LAJ, LH, LJ, LJC, LJC8, LJS LTJ, LTK1, LTR, LTS, L1, QB26, QH, QX, Q1, RX, R1, SAJ, SCJ, SD SJ, SJC1, SJC5, SKR, SMJ, SM11, SSK3, STP, STS, SX, SYA, S1 VED, VEK, VSX, VSX1, VSX2, WJ, WMA4, WMK, WMK2

NOTE A:PART NO. CHANGE D:NEWLY PROVIDED E:PART NO. DELETION K:REQUIRED NO. CORRECTION L:APPLICATION SERIAL NO. CORRECTION
T:APPLICATION CORRECTION Z:REMARKS CHANGE

PARTS CATALOGUE NEWS

BOOKNo. : 13ZK7402

Block No.	Ref. No.	Note	Part No.	Description	Reqd. QTY				Serial No.	Parts catalogue code	
					(1)	GX120K1 (2)	(3)	(4)			
E-16	5		18320-ZF1-H01	PROTECTOR, MUFFLER (STD.) (BLACK)	1	(1)	-	-	-----	-----	HHQ4, HTF2, HT2, HT24, HXU, HX2, HX26, HX4, LAJ4, LD, LHQ4 LJD2, LSJ, LSJ4, LX, LXU, LX2, LX4, PX, PX2, QA, QA2, QD, QHQ4 QH26, QJG2, QLL, QM, QMA4, QME4, QMX2, QT, QXS2, QXU, QX2 QX26, QX4, QX7, RD, RD4, RHC, RHQ4, RX4, SAJ4, SAR4, SD16 SD4, SH, SHQ4, SMW2, SM12, SM14, SSK1, SSS2, SSS4, SWX2 SWX4, SXS4, SX4, SX7, TX, TX2, TX26, TX4, UXU, VED1, VED6 VET, VEX, VEX7, VX, VXU, VX4, VX7, WDA6, WD12, WJP, WKD6 WKT2, WKT4, WKT6, WMA3, WME2, WME4, W1
					1	(1)	-	-	-----	4661346	DS, HX, H1, LAJ, LH, LJ, LJC, LJC8, LJS, LTJ, LTK1, LTR, LTS L1, QH, QX, Q1, RX, R1, SAJ, SCJ, SD, SJ, SJC1, SJC5, SKR, SMJ SM11, SSK3, STP, STS, SX, S1, VED, VEK, WJ, WMA4, WMK, WMK2
					-	-	1	1			
	A		18320-ZF1-H02	1	(1)	-	-	4661347	-----	DS, HX, H1, LAJ, LH, LJ, LJC, LJC8, LJS, LTJ, LTK1, LTR, LTS L1, QH, QX, Q1, RX, R1, SAJ, SCJ, SD, SJ, SJC1, SJC5, SKR, SMJ SM11, SSK3, STP, STS, SX, S1, VED, VEK, WJ, WMA4, WMK, WMK2

NOTE A:PART NO. CHANGE D:NEWLY PROVIDED E:PART NO. DELETION K:REQUIRED NO. CORRECTION L:APPLICATION SERIAL NO. CORRECTION
T:APPLICATION CORRECTION Z:REMARKS CHANGE